

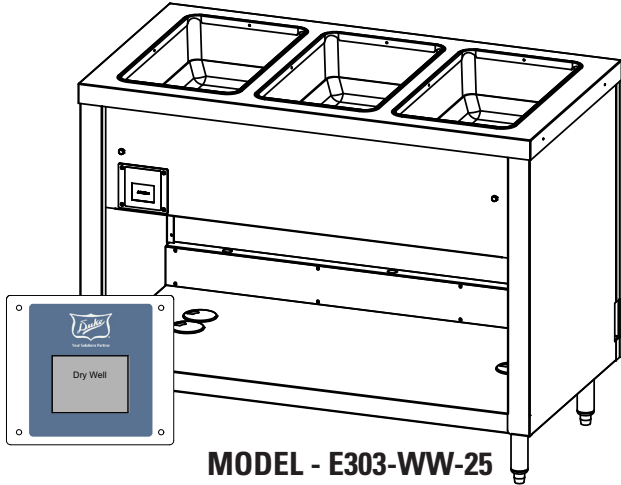

Your Solutions Partner

Specifications

F.O.B. Sedalia, Missouri 65301



MODEL - E303-WW-25

OPTIONS:

- Designer Food Guards
- Trayslides
- Sliding Doors
- Door Locks
- Adapter panels
- Telescope and flat covers
- Insets
- Spillage Pans
- Stainless steel carving boards
- Wood carving boards
- Stainless steel dish shelf
- Kick plates
- Drop brackets on tray slide
- Drop brackets on carving board
- Omit bottom shelf
- Tier of stainless steel angle sides
- Veneered plastic laminate panels on body
- Special powder coat painted body

AGENCY LISTINGS:



NSF/ANSI 4

DUKE MANUFACTURING CO.

2305 N. Broadway

St. Louis, MO 63102

800.735.3853 Toll Free

314.231.5074 Fax

www.dukemfg.com

SS-1254 Ganged Waterless Well - AeroServ

Approval Stamp(s):

PRODUCT INFORMATION:

PROJECT: _____

ITEM: _____

QUANTITY: _____

MODEL:

AeroServ Serving Systems

Hot Food Units - Ganged Waterless Well

- E302-WW-25 32"L - 2 top openings
- E303-WW-25 46"L - 3 top openings
- E304-WW-25 60"L - 4 top openings
- E305-WW-25 74"L - 5 top openings

BODY:

- Paint grip or stainless steel
- Choice of (12) powder coat paint colors
- Flanged or channeled edges
- Welded together with local reinforcements
- Mounted on 6" stainless steel legs with adjustable feet
- 20 gauge, 300 Series stainless steel
- Die stamped openings - 11-7/8" X 19-7/8"

Heat Compartments:

- 6-1/4" deep stainless steel liner for dry operation only
- Includes Silicone bottom pad
- Fully Insulated
- Rope element in each compartment

CONTROLS:

- Standard intuitive, easy to use touch screen control - One control for all wells
- Easily adjusted presets LOW/MED/HIGH
- Built in WIFI and Blue tooth for future connectivity.

Specification subject to change



AeroServ

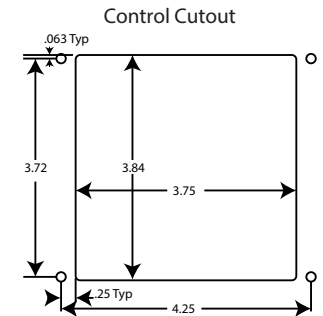
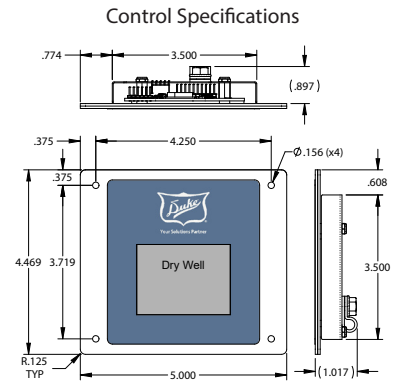
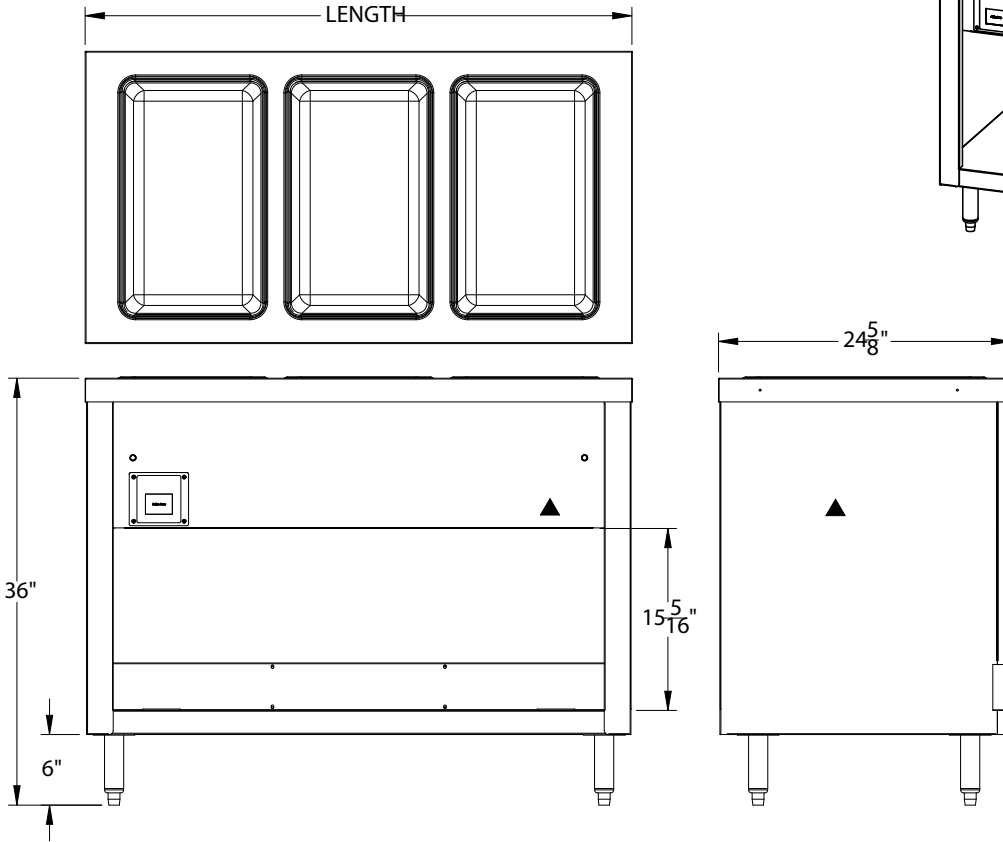
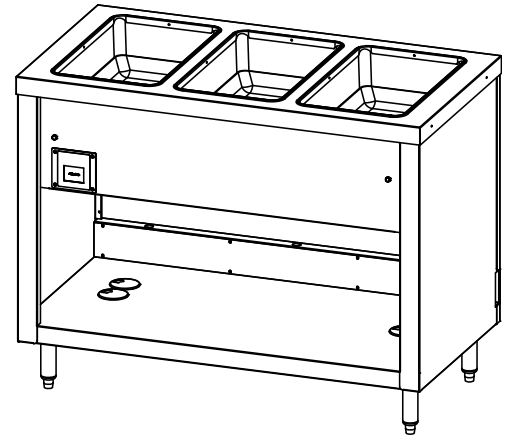

LEGEND	
▲	Electric connection

ELECTRICAL SPECIFICATIONS:

Model	120 Volt - 665 Watt			208 Volt - 500 Watt			240 Volt - 665 Watt		
	Watts	Amps	NEMA	Watts	Amps	NEMA	Watts	Amps	NEMA
E302-WW-25	1330	11.1	5-15	1000	4.8	6-20	1330	5.5	6-20
E303-WW-25	1995	16.6	L5-30	1500	7.2	6-20	1995	8.3	6-20
E304-WW-25	2660	22.2	L5-30	2000	9.6	6-20	2660	11.1	6-20
E305-WW-25	N/A	N/A	N/A	2500	12.1	6-20	3325	13.9	6-20

DIMENSIONS:

Freight Class: 150

Model	Length		Width		Height		Top Openings	Cube ft. crated	Weight	
	in	cm	in	cm	in	cm			lbs	kg
E302-WW-25	32	81.3	24.625	62.5	36	91.4	2	27.6	220	110.0
E303-WW-25	46	116.8	24.625	62.5	36	91.4	3	37.7	284	129.1
E304-WW-25	60	152.4	24.625	62.5	36	91.4	4	47.9	349	158.6
E305-WW-25	74	188.0	24.625	62.5	36	91.4	5	58.1	419	190.5



Duke Manufacturing Co.
 2305 N. Broadway
 St. Louis, MO 63102

Phone: 314-231-1130
 Toll Free: 1-800-735-3853
 Fax: 314-231-5074

www.dukemfg.com