

Champion[®]

The Dishwashing Machine Specialists

PROJECT: _____

ITEM # _____ QTY: _____

MODEL # _____

AIA # _____ SIS # _____

DH6000T VHR

VENTLESS HEAT RECOVERY EXTENDED HOOD-TYPE DOOR MACHINE



Rendered image is for general visual representation only. Please refer to specifications for the latest detailed product information.

OPTIONS & ACCESSORIES

- Built-in detergent and rinse aid pumps
- Drain water tampering kit (mounted)
- Racks (Peg, Flat, Sheetpan)
- Corner operation splash baffle
- Water hammer kit (unmounted)
- Pumped drain
- Dual point electrical connection
- Hose Install Kit

STANDARD FEATURES

- **27" Extended Hood Clearance**
- **Ventless Heat Recovery**
- **Advanced Touchscreen Display**
intuitive condition alerts, with multi-lingual user-friendly cleaning and operational guidance
- **Enhanced Visual On-Board Diagnostics**
quickly identify machine faults for rapid resolution and less downtime
- **Energy Saving Programmable Sleep Mode**
heaters power down after user determined period of inactivity
- **Rinse Sentry**
extends wash cycle until booster reaches optimal sanitization temperature before final rinsing process
- **40 Racks Per Hour**
- **0.73 Gallons Per Rack**
- **Factory Authorized Startup**
- **Field Convertible Electrical**
ability to convert from three phase to single phase incoming power
- **Door Interlock**
ensures maximum energy recovery and limits condensation from entering the dishroom
- **Automated Delime Function**
customizable alert intervals based on site water quality
- **Field Convertible Feed Orientation**
configurable for front load, corner installation, and pass through
- **NSF Dual**
rated conforms to NSF standards for stationary rack dish machine and pot and pan machine
- **Auto Start**
machine automatically starts selected wash cycle when door is closed
- **High Efficiency 2 HP Wash Pump**
- **Automatic Drain Valve**
heavy duty, gear driven full port ball valve stainless and brass construction
- **Vent Fan, Detergent, And Rinse Aid Signal Provided**
- **Four User Selectable Wash Cycles**
users can select 1, 2, 4, and 6 minute wash cycles depending on soil load
- **Cycle Counter**
records number of cycles machine has run since installation
- **Energy Star Certified**

SPECIFIER STATEMENT

Specified unit will be Champion model DH6000T with Ventless Heat Recovery and Condensate Removal, high temperature, high-hood type dishwashing machine. Features HMI controls, Rinse Sentry, Auto Start, up to 40 racks/hour, 0.73 US gals/rack [2.76 liters/rack, 0.61 imp. gals/rack].

1 year parts and labor warranty.



In the USA:

3765 Champion Blvd, Winston-Salem, NC 27105
Tel: (336) 661-1556 Fax: (336) 661-1979
www.championindustries.com

In Canada:

2674 N. Service Rd., Jordan Station, Ontario, Canada LORISO
Tel: (905) 562-4195 Fax: (905) 562-4618
www.championmoyerdiebel.ca

Champion®

The Dishwashing Machine Specialists

DH6000T VHR

VENTLESS HEAT RECOVERY EXTENDED HOOD-TYPE DOOR MACHINE

Shipping weight crated: 350 lbs. Dimensions shown in inches

SPECIFICATIONS

Capacities

Racks per hr. (NSF rated) 40
Wash tank (gal.) 10

Motor Horsepower

2 HP

Water Consumption

Gal. per hr. (max. use) 39
Gal. per rack 0.73

Temperature °F

Wash 150
Rinse 180

Heating

Tank heat, electric 5.2 kW
Electric Booster 7.5 kW

Selectable cycle times in minutes	Dish-washer Mode		Pot & Pan Mode	
	1	2	4	6
Time cycles in seconds				
Wash	36	94	214	334
Rinse	8	10	10	10
Sanitary Dwell	16	16	16	16
Vent Fan	30	30	30	30
Total	90	150	270	390

Machine & Built-in Booster (Standard)

Elec. Specs	Rated Amps	Min. Supply Ckt. Conductor Ampacity	Max. Overcurrent Protective Device
208-240/60/1	72-81	100	100
208-240/60/3	48-50	60	60
480/60/3	21	30	30

Machine Only (two point electrical connection or no built-in booster)

Elec. Specs	Rated Amps	Min. Supply Ckt. Conductor Ampacity	Max. Overcurrent Protective Device
208-240/60/1	36-39	50	50
208-240/60/3	26-27	30	30
480/60/3	10	15	15

Booster Only (two point electrical connection or no built-in booster)

Elec. Specs	Rated Amps	Min. Supply Ckt. Conductor Ampacity	Max. Overcurrent Protective Device
208-240/60/1	36-42	50	50
208-240/60/3	21-28	30	30
480/60/3	19	15	15

Plumbing Notes: Because of the variation in house-supplied steam and water pressures, steam and water pressure regulating valves (PRVs) may be needed. (Water PRV is standard on machines with booster.) The PRVs can either be purchased from Champion or obtained locally.

Champion does not endorse using on-demand (tankless) water heating systems, as well as PEX and other plumbing materials that may limit water flow, as these could impair machine performance. For optimal results, we recommend using appropriately sized conventional hot water tanks and standard copper water supply lines that adhere to our specifications. Not following these recommendations may void the manufacturer's warranty.

Water hardness of 3 grains/US Gal (0.83 Imp Gal) - 5.3 Mg/L or less

Utilities

- Electrical**
Machine Connection (see electrical box)
- Cold Water**
3/4" NPT Cold Water 50° - 75°F
45 PSI dynamic incoming
Final rinse 18 PSI
- Drain**
1" NPT Connection Gravity flow
15 Drain Max Flow Rate (g/min)
- Drain Water Tempering**
1/2" Cold water line with customer supplied cut-off valve (optional)
- Integrated Detergent System**
Detergent bottle supply connections (optional)

Warning: Plumbing, electrical connections should be made by qualified personnel who will observe all the applicable plumbing, sanitary and safety codes and the National Electrical Code.

Note: Optional Drain Tempering: 3/4" NPT cold water connection required. 3/4" NPT drain connection from back flow preventer to house drain. (FIELD INSTALLED and PLUMBED).

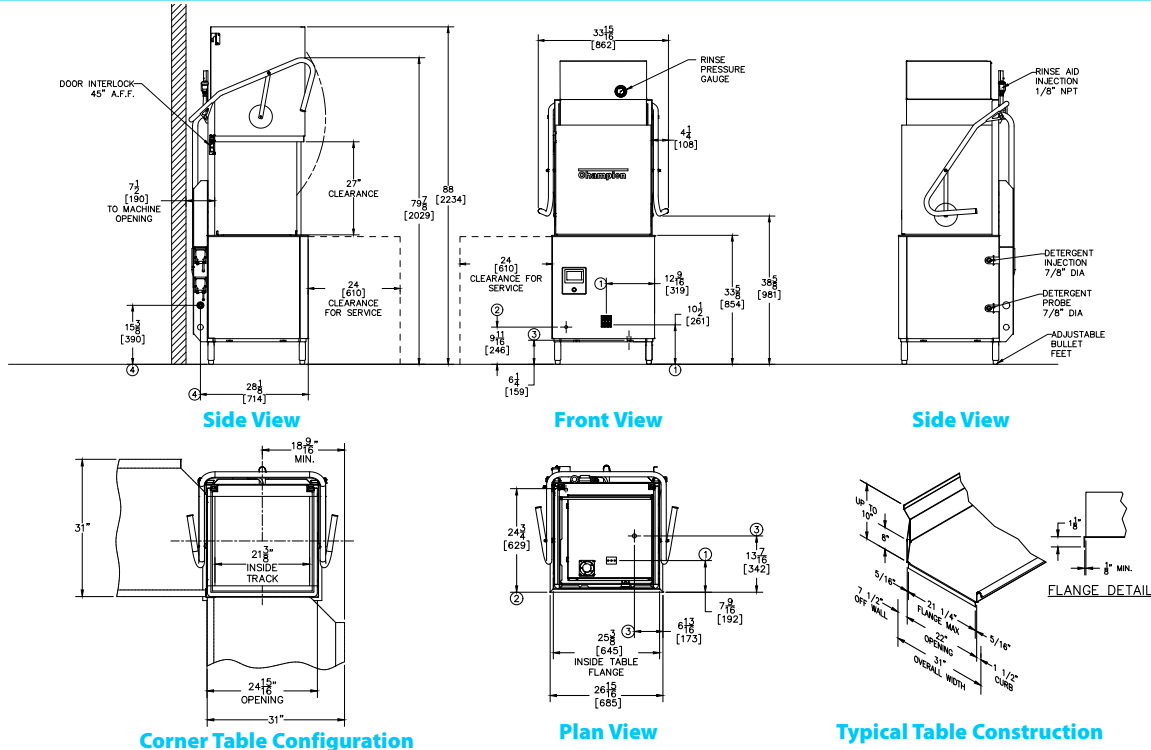

In the USA: 3765 Champion Blvd, Winston-Salem, NC 27105 | Tel: (336) 661-1556 Fax: (336) 661-1979 | www.championindustries.com

In Canada: 2674 N. Service Rd., Jordan Station, Ontario, Canada LOR1S0 | Tel: (905) 562-4195 Fax: (905) 562-4618 | www.championmoyerdiebel.ca

Rev. 04/2026 Printed in U.S.A.

Due to an ongoing value analysis program at Champion, specifications contained in this catalog are subject to change without notice.