

"OSE16R" OVERSHELVES - ECONOMY SERIES

Single Tier, 16GA w/1½" Rear Riser

FEATURES:

- Stainless Steel Shelf With Stallion Safety Edge On Front And 1-1/2" Turn-Up On Rear
- 16GA, Type 300 Stainless Steel With #4 Polish, Satin Finish
- Uprights Are 1" O.D. Round 18GA Tubing, Type 300 Stainless Steel With #4 Polish, Satin Finish
- Rear Or Center Mount (Please Specify) Single Overshelves Are Mounted 18" Above Table Top
- Overshelves Feature Knockdown Setup All Models Are Approved By The National Sanitation Foundation

SPECIFICATIONS:

- Stainless Steel Overshelves Are TIG Welded
- Exposed Welds Are Polished To Match Adjacent Surfaces
- Shelf: 16GA, Type 300 Stainless Steel, #4 Polish, Satin Finish
- Uprights: 1" Round O.D., 18GA Type 300 Tubular Stainless Steel #4 Polish, Satin Finish
- Heat Lamp Provision: OSEHLP-6XX 6=Width Of Provision, XS=Nominal Length Of Shelf

CERTIFICATIONS:



OSE16RK-1260

"OSE16R" OVERSHELVES - ECONOMY SERIES

LENGTH (L)	12" WIDTH	WT (LBS)	18" WIDTH	WT (LBS)
36"	OSE16RK-1236	14	OSE16RK-1836	18
48"	OSE16RK-1248	16	OSE16RK-1848	22
60"	OSE16RK-1260	19	OSE16RK-1860	26
72"	OSE16RK-1272	22	OSE16RK-1872	31
84"	OSE16RK-1284	25	OSE16RK-1884	35
96"	OSE16RK-1296	28	OSE16RK-1896	40
108"	OSE16RK-12108	31	OSE16RK-18108	44
120"	OSE16RK-12120	36	OSE16RK-18120	49
132"	OSE16RK-12132	40	OSE16RK-18132	53
144"	OSE16RK-12144	45	OSE16RK-18144	57

ALL DIMENSIONS ARE TYPICAL. TOLERANCE +/- .500". JOHN BOOS & CO. RESERVES THE RIGHT TO CHANGE SPECIFICATIONS WITHOUT NOTICE.

DETAILED SPECIFICATIONS

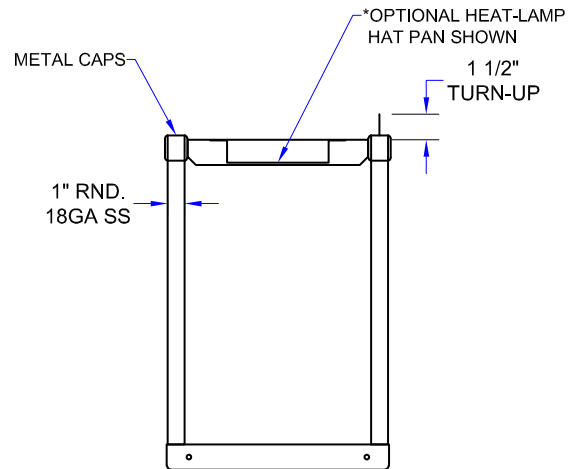
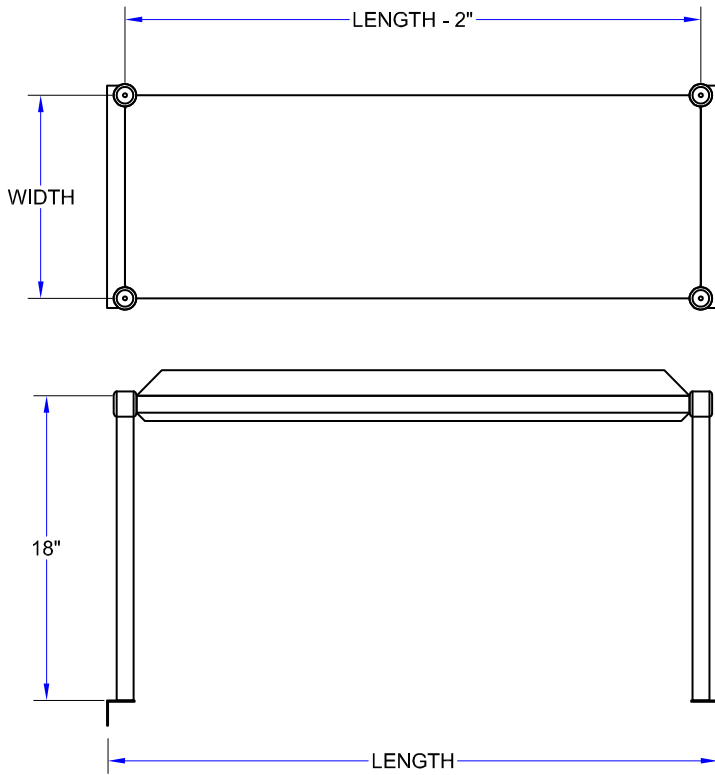

MODEL # STRUCTURE

16 = GA

1 = # OF SHELVES

E = ECONOMY

OS = OVERSHELF

R = 1-1/2" Riser Top

K = Knockdown

12 = Width (Front/Back)

36 = Length (Left/Right)

OSE16RK-1236

"OSE16R" OVERSHELVES - ECONOMY SERIES

LENGTH (L)	12" WIDTH	WT (LBS)	18" WIDTH	WT (LBS)
36"	OSE16RK-1236	14	OSE16RK-1836	18
48"	OSE16RK-1248	16	OSE16RK-1848	22
60"	OSE16RK-1260	19	OSE16RK-1860	26
72"	OSE16RK-1272	22	OSE16RK-1872	31
84"	OSE16RK-1284	25	OSE16RK-1884	35
96"	OSE16RK-1296	28	OSE16RK-1896	40
108"	OSE16RK-12108	31	OSE16RK-18108	44
120"	OSE16RK-12120	36	OSE16RK-18120	49
132"	OSE16RK-12132	40	OSE16RK-18132	53
144"	OSE16RK-12144	45	OSE16RK-18144	57

ALL DIMENSIONS ARE TYPICAL. TOLERANCE +/- .500". JOHN BOOS & CO. RESERVES THE RIGHT TO CHANGE SPECIFICATIONS WITHOUT NOTICE.