



VACUUM PACKING MACHINE SE-520 CC 120/60/1

Tabletop model. 848 cf/h. 17 + 17"



P/N. 1141152



SALES DESCRIPTION

Two sealing bars (17 + 17").
848 cf/h Busch vacuum pump.
Vacuum controlled by sensor.

- ✓ Powered by Busch.
- ✓ Vacuum controlled by sensor.
- ✓ Vacuum PLUS.
- ✓ Digital keyboard.
- ✓ Control panel equipped with display indicating the exact vacuum percentage.
- ✓ "Pause" button to marinate food.
- ✓ Safe liquid packing thanks to sensor control.
- ✓ Double seal.
- ✓ Cordless sealing bar.
- ✓ Bag-sealing programme.
- ✓ Pulse-controlled decompression.
- ✓ Vac-Norm ready with Automatic decompression.
- ✓ Stainless steel body and chamber. Long-shaped, deep-drawn chamber.
- ✓ Damped transparent lid.
- ✓ Dry-oil programme for drying the pump.
- ✓ Working hours counter for oil changes.
- ✓ Safety system with protection against vacuum failure.

INCLUDES

- ✓ Sensor controls.
- ✓ Up to 10 seconds of extra vacuum pull.
- ✓ Soft air function.
- ✓ Dry oil cycle.
- ✓ Busch pump.
- ✓ NSF approved.
- ✓ Clear methacrylate lid.
- ✓ Filling plate.

OPTIONAL

- Vacuum packing bags.
- External vacuum kit for Vac-Norm, containers and accessories.
- Bag cutting kit.
- Support for liquid packaging.
- Additional filling plates.

ACCESSORIES

- Bag cutting kits
- Filling plates
- Liquid insert plates
- Vac-norm external vacuum kit
- Vac-norm containers
- Smooth bags for vacuum packing
- Trolley for vacuum packing machines
- Vacuum packing machines maintenance kits

SPECIFICATIONS

Pump capacity: 848 cf/h
 Bar length: 17 + 17"
 Total loading: 1.25 Hp
 Vacuum pressure (maximum): 2 mbar
 Electrical supply: 120 V / 60 Hz / 1~ (13 A)
 Plug: USA (NEMA 5-15P / 2P+G)

Internal dimensions

- ✓ Width: 22.3"
- ✓ Depth: 16.9"
- ✓ Height: 8.4"

External dimensions (W x D x H)

- ✓ Width: 24.9"
- ✓ Depth: 21.7"
- ✓ Height: 23.4"

Net weight: 167.55 lb
 Noise level (1m.): 75 dB(A)
 Background noise: 32 dB(A)
 Crated dimensions
 30.9 x 24.1 x 27.0 "
 Gross weight: 188.3 lbs.

FOOD PRESERVATION AND SOUS-VIDE
COMMERCIAL VACUUM PACKING MACHINES

product sheet
updated 13/03/2026



SAMMIC, S.L. · Basarte, 1
20720 AZKOITIA (Gipuzkoa) · SPAIN

Intertek



VACUUM PACKING MACHINE SE-520 CC 120/60/1

Tabletop model. 848 cf/h. 17 + 17"



P/N. 1141152

FOOD PRESERVATION AND SOUS-VIDE
COMMERCIAL VACUUM PACKING MACHINES

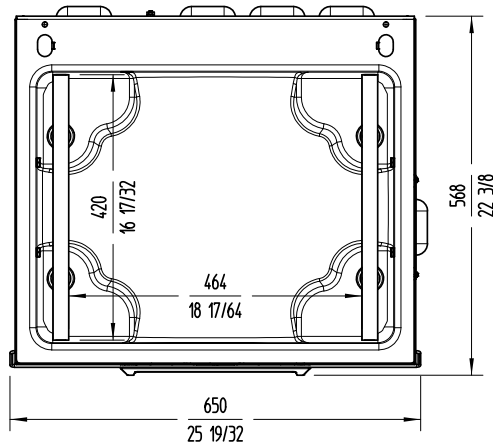
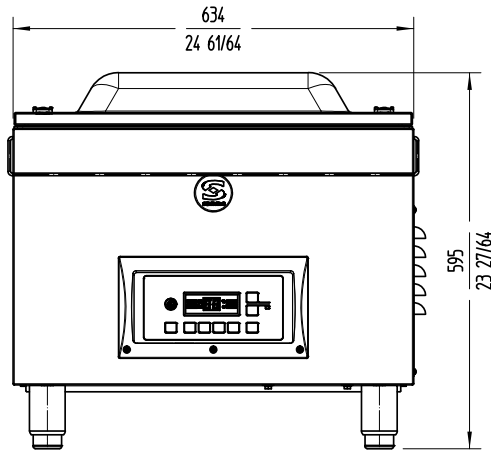
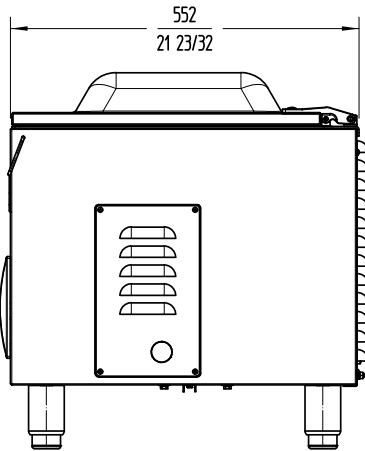

sammic | sammic.us
Food Service Equipment Manufacturer

usa@sammic.com phone +1 (224) 307-2232
 1225 Hartrey Avenue toll free +1 844 275 3848
 60202-1056 Evanston, IL



Project	Date
Item	Qty
Approved	

product sheet
updated 13/03/2026