



GAS

TUBE FIRED FRYER - 25/25 lb Floor Model



IFS-2525

Shown with included legs



Robotic welding is precise, virtually eliminating leaks.

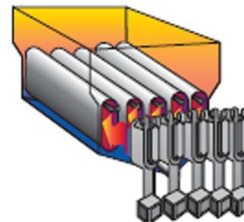

Tube fired burners have a large heat transfer area.

TUBE FIRED BURNERS

- High efficiency cast iron burners have a large heat transfer area.
- Tubes are constructed of heavy gauge metal with a built-in deflector system.
- 70,000 BTU (21 KW) total output.
- Millivolt temperature control circuit
- Snap acting electronic thermostat has a 200°F - 400°F (93°C - 204°C) temperature range.
- Fast recovery to desired temperature.
- Heats oil quickly producing a better tasting product with less oil absorption.
- 100% safety shut-off

STAINLESS STEEL FRYPOTS

- Frying area is 6 3/4" x 14" (171 x 356mm).
- Frypot tubes and sides are robotically welded stainless steel to virtually eliminate leaks.
- Fine mesh wire crumb screen is included.
- Recessed bottom facilitates draining, slants toward the drain.
- 1-1/4" (32 mm) full port drain valve empties frypot quickly and safely.
- One large, nickel-plated fry basket with vinyl coated, heat protective, handle is included.
- Basket hanger is stainless steel.

EXTERIOR FEATURES

- Stainless steel front, door, sides, basket hanger and frypot.
- Welded and polished stainless steel seams.
- Full heat shield protects control panel.
- Full bottom chassis provides structural support.
- Plate mounted 6" high (152 mm) heavy duty stainless steel legs or optional casters assure secure support.
- One year parts and labor warranty. Limited warranty on frypot, stainless steel frypot is five years pro-rated.

LARGE COOL ZONE

- Captures and holds particles out of the fry zone
- Reduces taste transfer



1128 Sherborn Street | Corona, CA 92879 | 800.343.7790 | imperialrange.com | imperialsales@imperialrange.com

© 2026 Imperial Commercial Cooking Equipment Imperial reserves the right to change specifications at any time without prior notice and without any obligation for past or future equipment purchases. Visit www.imperialrange.com for specification updates



GAS

TUBED FIRED FRYER - 25/25 LB FLOOR MODEL

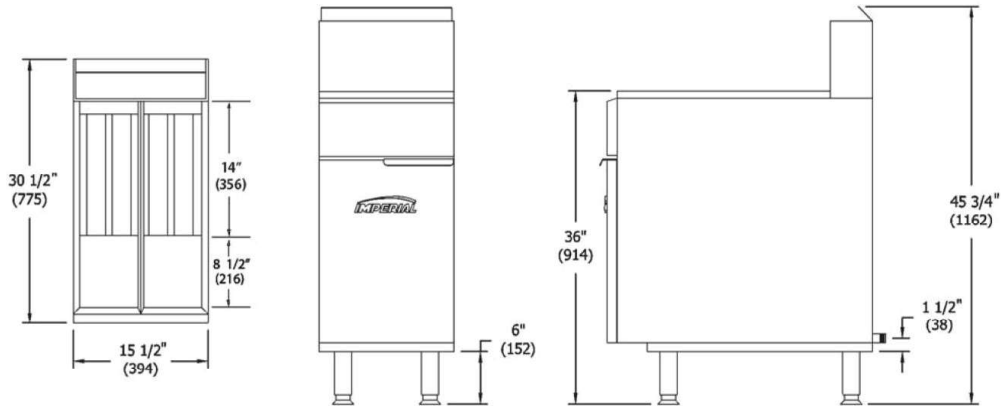

MODEL	OIL CAPACITY	GAS OUTPUT		#OF BURNERS	SHIP WEIGHT (KG) LBS
		BTU	(KW)		
IFS-2525	25 lbs. (14 L) per frypot	140,000	(41)	4	(104) 230
IF-DS	N/A, drain station	N/A	N/A	N/A	(60) 130

MANIFOLD PRESSURE		MANIFOLD SIZE
NAT GAS	PROPANE	
4.0" W.C.	11.0" W.C.	¾" (19 MM)

Specify elevation, if over 2,000 ft.

MODEL	FRYER AREA	DIMENSIONS			CRATED DIMENSIONS		
		15½"W (394)	30½"D (775)	45¾"H (1162)	17"W (432)	34" (864)	38" (965)
IFS-2525	6¾" X 14" (171 X 356 mm)	15½"W (394)	30½"D (775)	45¾"H (1162)	17"W (432)	34" (864)	38" (965)
IF-DS	N/A, drain station	15½"W (394)	30½"D (775)	44¼"H (1124)	17"W (432)	34" (864)	38" (965)

Measurements in () are metric equivalents



MADE IN USA

OPTIONS AND ACCESSORIES

- Fryer drain station with storage cabinet
- Manual timer
- Catering package for easy transporting
- Extra fry baskets with vinyl coated handles
- Gas shut off valve, ¾" N.P.T.
- Fryer Tip Brush
- Goofer Declogger Rod
- Sediment Scooper
- Quick disconnect and flexible gas hose, ¾" N.P.T.
- 6" (152 mm) casters

CLEARANCE REQUIREMENTS

For use only on non-combustible floors. Legs or casters are required for non-combustible floors; or 2" (51 mm) overhang is required when curb mounted. Provide 0" clearance from non-combustible surfaces and 6" (152 mm) from combustible surfaces.

