

SEAGATE

PIZZA PREP PIZZA PREPARATION TABLES

SEAGATE refrigerated counter/prep tables were designed to deliver quality and performance at an affordable price. The pizza prep series is excellent for storing & prepping pizza and sandwich food products.

Toppings, sauces and cheeses stay fresh thanks to the robust refrigeration system that keeps temperatures cold and consistent. The digital controller/display makes maintaining tight temperature ranges easier and allows for adjusting refrigeration cycles if needed.

All units are equipped with one adjustable shelf per door and a heavy duty 14.9" deep cutting board.

The solid hinged door has a recessed handle for quick easy access and will hold open at 90° for easier stocking. The easy-to-clean stainless steel interior and exterior has anti-corrosive properties that make maintenance easier, too.

SEAGATE, it means a great deal.



STANDARD FEATURES

- Electronic thermostat and an easy-to-read digital LED temperature display for optimal accuracy
- 90 degree hold open door for easier stocking
- 14.9" deep cutting board included
- 1/3 x 4" deep Portion Control pans included
- Side mount compressor for enhanced efficiency
- Easy to mount 4" casters with two lockable front casters
- All stainless steel exterior & interior
- CFC free refrigerant and foam insulation
- Auto defrosting and auto evaporation of condensation water
- Magnetic gasket can be replaced without any tools

AVAILABLE EXCLUSIVELY AT BURKETT RESTAURANT EQUIPMENT & SUPPLIES | BURKETT.COM/BRAND/SEAGATE | 419-720-8190

SEAGATE



SPP71



SPP94

SPECIFICATIONS

MODEL NUMBER	SPP71	SPP94
DOORS	2	3
NUM. OF 1/3 SIZE PANS	9	12
CU/FT	22	32
SHELVES	2	3
H/P	1/2	3/4
AMPS	5	5.5
VOLTAGE	115/60/1	115/60/1
WEIGHT (lbs)	432	582
ENERGY CONSUMPTION Kwh/24hr	13.8	15.18
ENERGY CONSUMPTION Kwh/6hr	3.45	3.795
EXTERIOR DIMENSIONS (WXDXH)	70.8" x 32.3" x 41.7"	94.2" x 32.3" x 41.7"
TEMPERATURE RANGE	33 to 40°F	33 to 40°F
PLUG TYPE	NEMA 5-15P	NEMA 5-15P

WARRANTY

2-YR PARTS & LABOR WARRANTY
5 YEAR COMPRESSOR WARRANTY

Specifications are subject to change without notice.

AVAILABLE EXCLUSIVELY AT BURKETT RESTAURANT EQUIPMENT & SUPPLIES | BURKETT.COM/BRAND/SEAGATE | 419-720-8190





TECHNICAL DRAWINGS

SPP71
FRONT

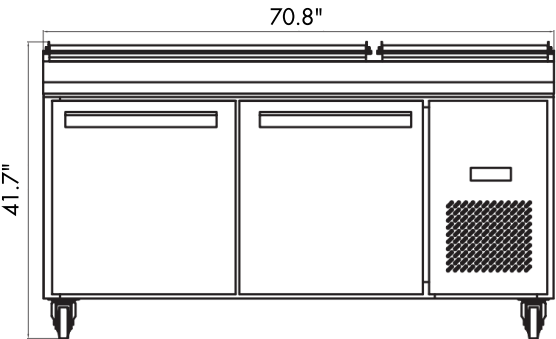

SPP94
FRONT

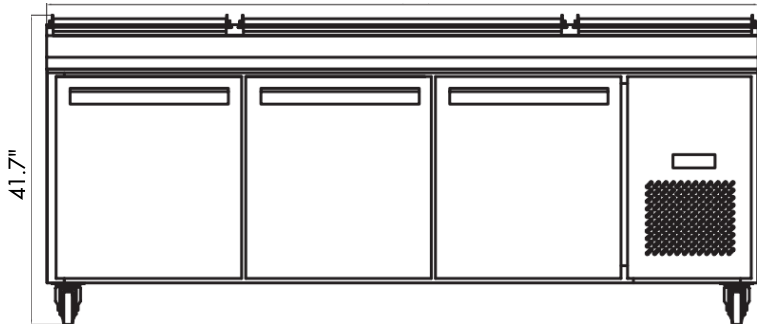

SPP71
TOP

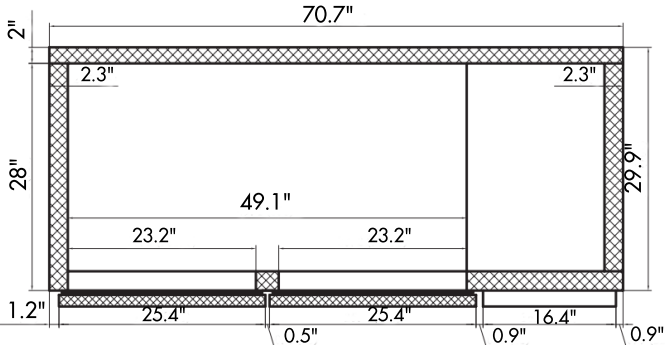

SPP94
TOP

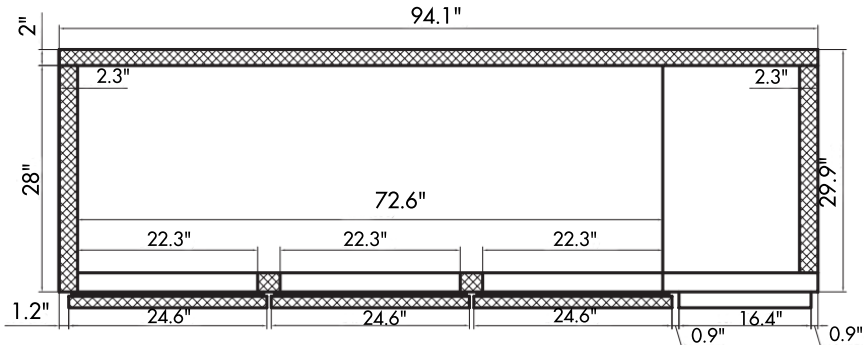

SPP71
TOP



SPP94
TOP

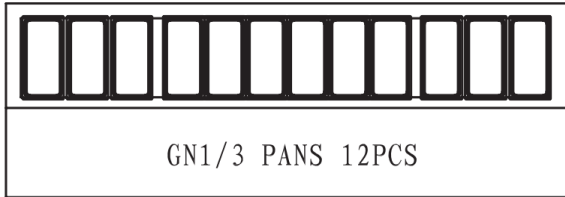

2,3 DOOR
SIDE

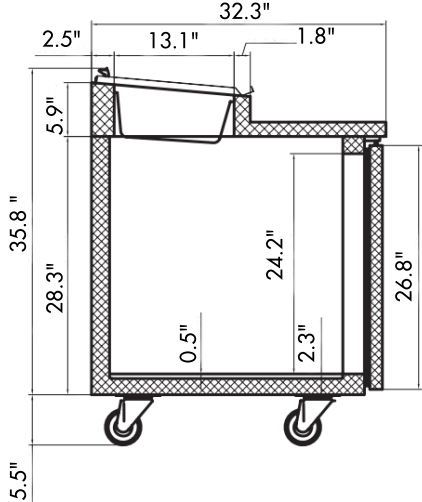

Specifications are subject to change without notice.

