

DISPLAY FREEZER (0°F)

Model: 1FSNGD

Natural Refrigerant R-290 Model

1-Section Display Reach-In Freezer with Hinged Glass Door Shallow Depth

- 1FSNGD** - Stainless steel front, aluminum end panels and interior
- 1FSNSAGD** - Stainless steel exterior, aluminum interior
- 1FSNSSGD** - Stainless steel exterior and interior



Options and Accessories

(upcharge and lead times may apply)

Stainless steel case back	Rehinging of door (consult factory)
Add'l epoxy-coated steel shelves	Adjustable legs
Chrome or stainless steel shelves	Special electrical req. (consult factory)
Heavy-duty pilaster strips	

Consult factory for other model configurations, options and accessories.

Project Name:

Model Specified:

Location:

Item No:

Quantity:

AIA #:

SIS #:

Standard Model Features

REFRIGERATION SYSTEM

Self contained, performance-rated refrigeration system

Natural, environmentally-safe, high-efficiency R-290 refrigerant¹

Automatic, electric condensate evaporator

Expansion valve system

Standard operating temperature is 0 to -5°F and can be adjusted to operate as low as -10°F in a 90°F ambient.

CABINET ARCHITECTURE

3" non-CFC polyurethane foam insulation

Triple-pane, tempered hinged glass door

Chrome-plated door handle

Cam action, lift-off hinges

Self-closing door

Magnetic snap-in door gasket

Cylinder lock in door

Heavy-duty, epoxy-coated steel shelves

5" casters

MODEL FEATURES

LED interior lighting

Electronic controller w/digital display & hi-low alarm

Automatic electric defrost

¹ R-290 refrigerant meets all federal and state regulatory requirements.

Continental
Refrigerator

Toll-Free: 800-523-7138
Phone: 215-244-1400
Fax: 215-244-9579

539 Dunksferry Road
Bensalem, PA 19020
www.continentalrefrigerator.com

APPROVAL:

Model Specifications

DIMENSIONAL DATA

Net Capacity (cu. ft.)	16 (453 cu l)
Width, Overall (in.)	26 (660 mm)
Depth, Overall (in.) (incl. handle)	29 1/4 (743 mm)
Depth (in.) (less door)	25 7/8 (657 mm)
Depth (in.) (door open 90°)	49 1/2 (1257 mm)
Clear Door Width (in.)	19 3/8 (492 mm)
Clear Door Height (in.)	58 5/8 (1489 mm)
Height, Overall (in.) (incl. 5" casters)	82 1/4 (2089 mm)
No. of Doors	1
No. of Shelves	4
Shelf Area (sq. ft.)	20.4 (1.9 sq m)

REFRIGERANT DATA

Condensing Unit Size (H.P.)	1/2
Capacity (BTU/Hr)*	2470

ELECTRICAL DATA

Voltage (int'l)	115/60/1 (220/50/1)
Feed Wires (incl. ground)	3
Total Amps (int'l)	8.2 (5.8)
Defrost Amps (int'l)	4.4 (3.2)
10 ft. Cord/Plug [attached] (int'l)	Yes (No)

SHIPPING DATA

Height - Crated (in.)	85 1/2 (2172 mm)
Width - Crated (in.)	31 5/8 (803 mm)
Depth - Crated (in.)	42 (1067 mm)
Volume - Crated (cu. ft.)	65 (1841 cu l)
Weight Std - Crated (lbs.)	320 (145 kg)
Weight SS - Crated (lbs.)	320 (145 kg)

* Rating @ -15°F evaporator, 90°F ambient

Figures in parentheses reflect metric equivalents rounded to the nearest whole unit.



Equipped with one NEMA-5-15P Plug
(varies by country)

Model Plan Views

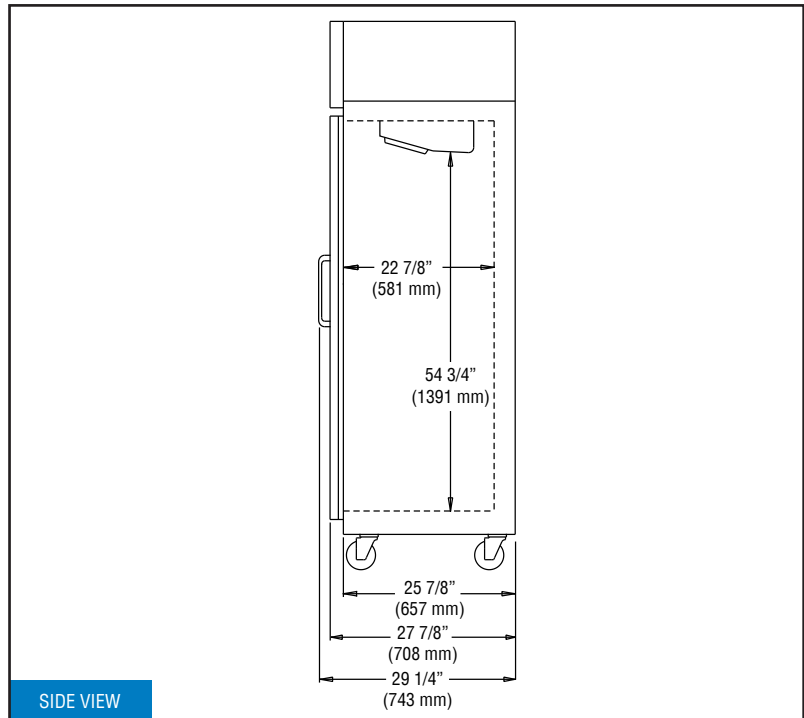
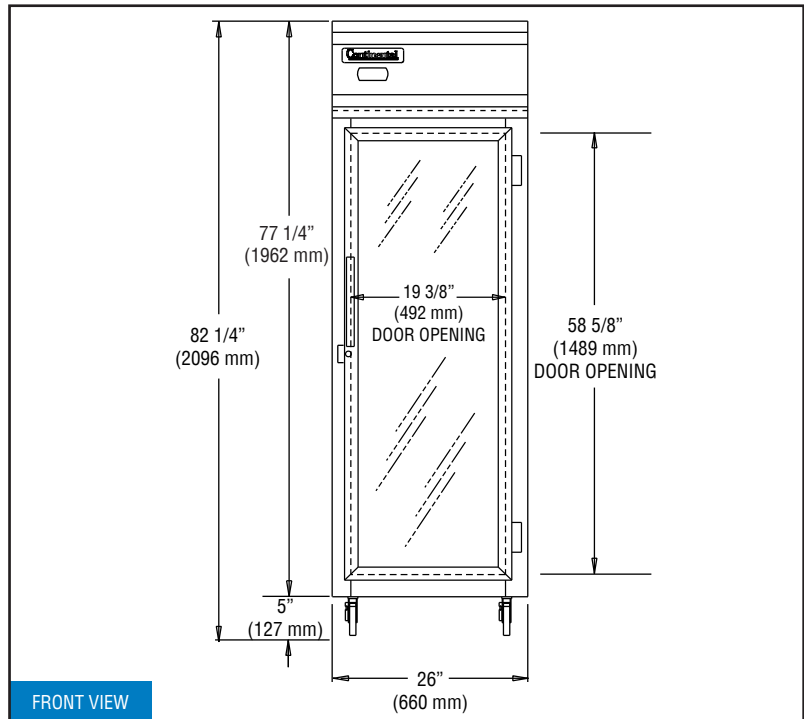

IMPORTANT NOTE: If the cabinet is located directly against a wall and/or under a low ceiling, a minimum clearance of 12" is required on top and 3" on sides and rear.

Continental
Refrigerator

Toll-Free: 800-523-7138
Phone: 215-244-1400
Fax: 215-244-9579

539 Dunkserry Road
Bensalem, PA 19020
www.continentalrefrigerator.com

Due to our continued efforts in developing innovative products, specifications subject to change without notice.



Intertek



MADE IN THE U.S.A.

© Copyright 2019, Continental Refrigerator.
A Division of National Refrigeration & Air Conditioning Products, Inc.