



Profit from the Eagle Advantage®

# Specification Sheet

## Short Form Specifications

Eagle Panco® Half Size Mobile Can Rack, with aluminum top, model \_\_\_\_\_. All-welded aluminum construction, crossbraced front-to-back and side-to-side. Aluminum angle racks secured to frame at a slight angle to allow for gravity feed. Furnished with 4"-diameter casters. Capacity to be (54, 72) #10 cans or (72, 96) #5 cans.

Eagle Panco® Half Size Mobile Can Rack, with 1/2"-thick polymer top, model \_\_\_\_\_. All-welded aluminum construction crossbraced front-to-back and side-to-side. Aluminum angle racks secured to frame at a slight angle to allow for gravity feed. Furnished with 4"-diameter casters. Capacity to be (54, 72) #10 cans or (72, 96) #5 cans.



model #OCR-10-4A  
can rack with  
aluminum top

## Options / Accessories

- Casters with locking brakes
- Perimeter bumpers
- Vertical corner bumpers

## EAGLE GROUP

100 Industrial Boulevard, Clayton, DE 19938-8903 USA  
 Phone: 302-653-3000 • 800-441-8440 • Fax: 302-653-2065  
[www.eaglegrp.com](http://www.eaglegrp.com)  
[www.eaglegrpnews.com](http://www.eaglegrpnews.com)  
[www.eaglegrp.com](http://www.eaglegrp.com)

For custom configuration or fabrication needs, contact our **SpecFAB® Division**.  
 Phone: 302-653-3000 • Fax: 302-653-2065 • e-mail: [quotes@eaglegrp.com](mailto:quotes@eaglegrp.com)

Item No.:	_____
Project No.:	_____
S.I.S. No.:	_____

# Panco® Can Racks —Half Size

## MODELS:

- OCR-10-3A
- OCR-10-4A
- OCR-10-3AP
- OCR-10-4AP

## Design and Construction Features

- All-welded construction. All racks are constructed of high-strength aluminum sections.
- Frame and supports: square aluminum tubing. Crossbraced front-to-back and side-to-side on top and bottom of unit.
- Rack slides made from aluminum angles secured to frame at a slight angle for gravity feed.
- Casters: 4" (127mm)-diameter non-marking swivel plate casters with polymer tread.
- Offered with aluminum or 1/2" (13mm)-thick poly top.
- Provides automatic stock rotation when loaded from rear.
- Shipped assembled.





Item No.: \_\_\_\_\_  
 Project No.: \_\_\_\_\_  
 S.I.S. No.: \_\_\_\_\_

## Panco® Can Racks—Half Size

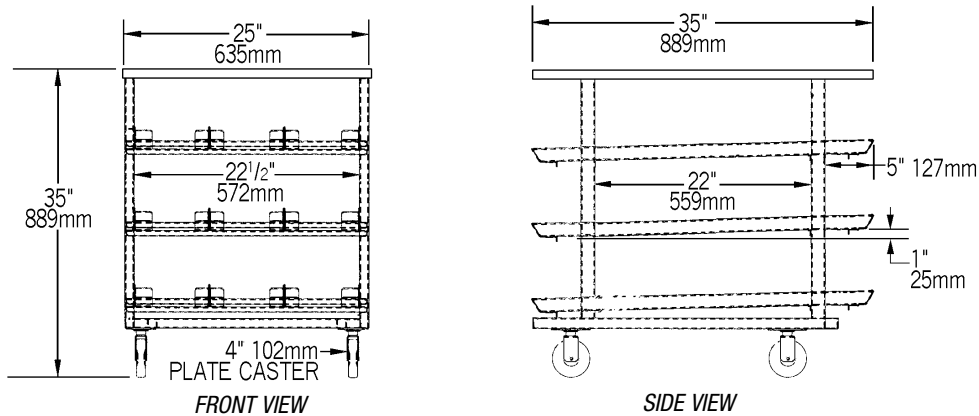

(#OCR-10-3A SHOWN)

### Racks with Aluminum Top

model #	description	overall dimensions						sliding space	can capacity		# of tiers high	weight		
		width in.	width mm	depth in.	depth mm	height in.	height mm		#10	#5		lbs.	kg	
OCR-10-3A	half size, mobile	25"	635	35"	889	35"	889	7 1/2"	191	54	72	3	51	23.1
OCR-10-4A	half size, mobile	25"	635	35"	889	41"	1041	7 1/2"	191	72	96	4	62	28.1

### Racks with 1/2" (13mm)-thick Poly Top

model #	description	overall dimensions						sliding space	can capacity		# of tiers high	weight		
		width in.	width mm	depth in.	depth mm	height in.	height mm		#10	#5		lbs.	kg	
OCR-10-3AP	half size, mobile	25 1/2"	648	35 1/2"	892	32 3/4"	822	7 1/2"	191	54	72	3	51	23.1
OCR-10-4AP	half size, mobile	25 1/2"	648	35 1/2"	892	40 1/2"	1038	7 1/2"	191	72	96	4	62	28.1

**EAGLE GROUP**  
 100 Industrial Boulevard, Clayton, DE 19938-8903 USA  
 Phone: 302-653-3000 or 800-441-8440 • Fax: 302-653-2065  
 www.eaglegrp.com • www.eaglegrpnews.com • www.eaglehmc.com

Printed in U.S.A.  
 ©2022 by Eagle Group

Rev. 11/22

Spec sheets available for viewing, printing or downloading from our online literature library at our websites

Although every attempt has been made to ensure the accuracy of the information provided, we cannot be held responsible for typographical or printing errors. Information and specifications are subject to change without notice. Please confirm at time of order.