

BOTTLE COOLER (38°F - 41°F)

Model: BC24NSS

24" Bottle Cooler

Stainless steel exterior with all stainless steel countertop and slide lid, heavy duty galvanized interior.



Options and Accessories

(upcharge and lead times may apply)

Stainless steel interior	Casters
Additional wire bin dividers	Adjustable legs
Lid lock	

Consult factory for other model configurations, options and accessories.

Continental
Refrigerator



Project Name:

Model Specified:

Location:

Item No:

Quantity:

AIA #:

SIS #:

Standard Model Features

REFRIGERATION SYSTEM

Environmentally safe R-290 refrigerant

Performance rated **front breathing** refrigeration system

Automatic, hot gas condensate evaporator

Full length, extra large coil

Easily accessible and serviceable slide out condensing unit

CABINET ARCHITECTURE

High density, non-CFC polyurethane foamed-in-place insulation

Heavy duty, epoxy coated, adjustable steel wire storage bin dividers

MODEL FEATURES

Heavy duty cap opener with extra capacity, removable cap catcher

Easily accessible, front mounted cleanout drainage hose

Electronic control, off-cycle defrost

APPROVAL:

Model Specifications

DIMENSIONAL DATA

Net Capacity (cubic feet)	4.8 (136 l)
12 oz. Bottle Capacity (# cases)	4 1/2
12 oz. Can Capacity (# cases)	7 1/2
Width, Overall (inches)	24 (610 mm)
Depth, Overall (inches) (including bumpers & cap catcher)	29 1/8 (740 mm)
Height, Overall (inches)	34 3/4 (883 mm)
Number of Slide Lids	1
Number of Bin Dividers	2

REFRIGERANT DATA

Condensing Unit Size (H.P.)	1/5
R-290 Refrigerant Charge (oz)	2.5
Capacity (BTU per hour)*	1330

ELECTRICAL DATA

Voltage (International)	115/60/1 (220/50/1)
Feed Wires (including ground)	3
Total Amps (International)	2.3 (1.1)
10 ft. Cord/Plug [attached] (International)	Yes (No)

SHIPPING DATA

Weight - (pounds)	225 (110 kg)
Height - Crated (inches)	45 (1022 mm)
Width - Crated (inches)	31 (768 mm)
Depth - Crated (inches)	36 (838 mm)

* Rating @ +20°F evaporator, 90°F ambient
 Figures in parentheses reflect metric equivalents rounded to the nearest whole unit.



Equipped with one NEMA-5-15P Plug
 (varies by country)

Model Plan Views

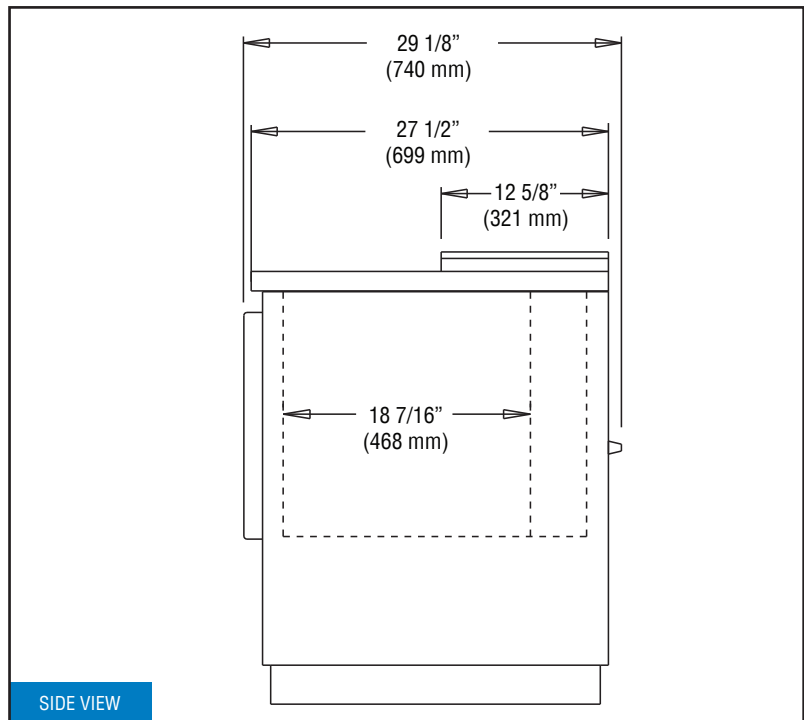
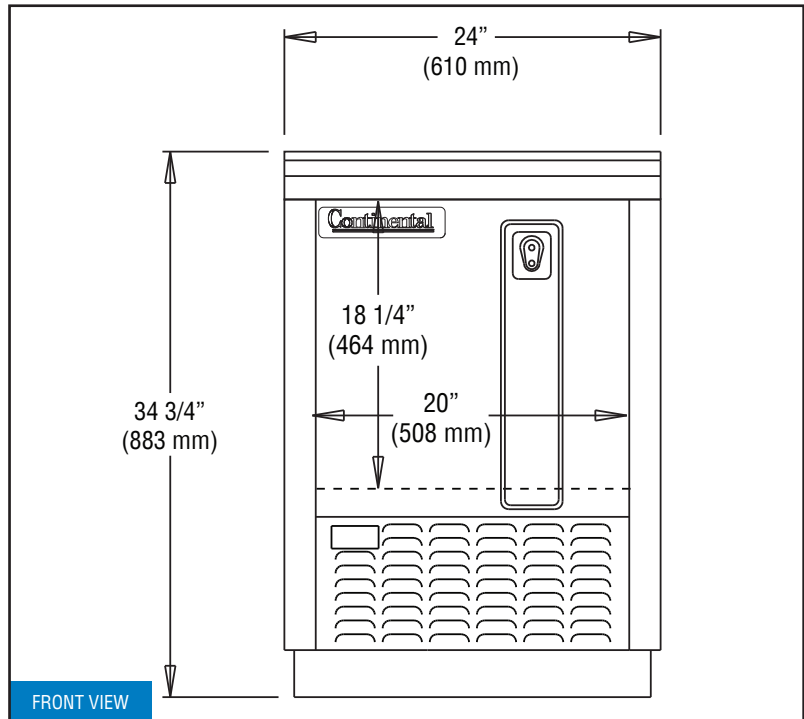

IMPORTANT NOTE: Model is completely front breathing and takes in and exhausts air through the front grill. A clearance of 1" on the back and 3" on the sides is recommended.



Toll-Free: 800-523-7138
 Phone: 215-244-1400
 Fax: 215-244-9579

539 Dunksferry Road
 Bensalem, PA 19020
www.continentalrefrigerator.com

Due to our continued efforts in developing innovative products, specifications subject to change without notice.



PROUDLY
 DESIGNED & ASSEMBLED
 IN THE U.S.A.