

Expanding Stem Casters

2" Stem Work Table Caster with Gray Rubber Wheel

Certifications:



Features:

- Fits Standard 2" Tubing by Expanding the Stem Creating a Secure Fit
- Double Ball Bearing Raceway for Long Wear and Added Strength
- With or Without Top Lock Brake
- Raceway Dust Cover

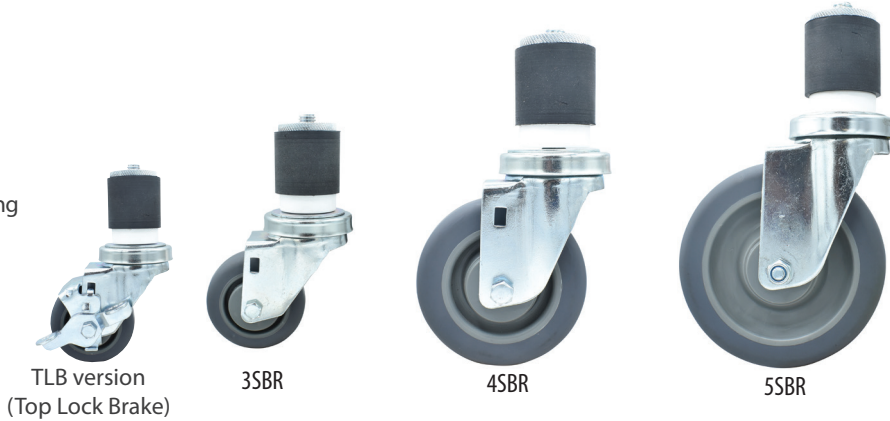

Material:

- Resistant to Oil, Grease, Water and Most Solvents
- Non-marking
- Temperature Range -45° to 180°F
- Nylon Bearing Sleeve
- Gray Rubber Wheel

Part Number	Brake	Exposed Height	Wheel Size	Capacity
3SBR-4RA-GR	-	4.125"	3"	250 LBS
3SBR-4RA-GR-TLB	TLB	4.125"	3"	250 LBS
4SBR-4RA-GR	-	5"	4"	250 LBS
4SBR-4RA-GR-TLB	TLB	5"	4"	250 LBS
5SBR-4RA-GR	-	6"	5"	250 LBS
5SBR-4RA-GR-TLB	TLB	6"	5"	250 LBS

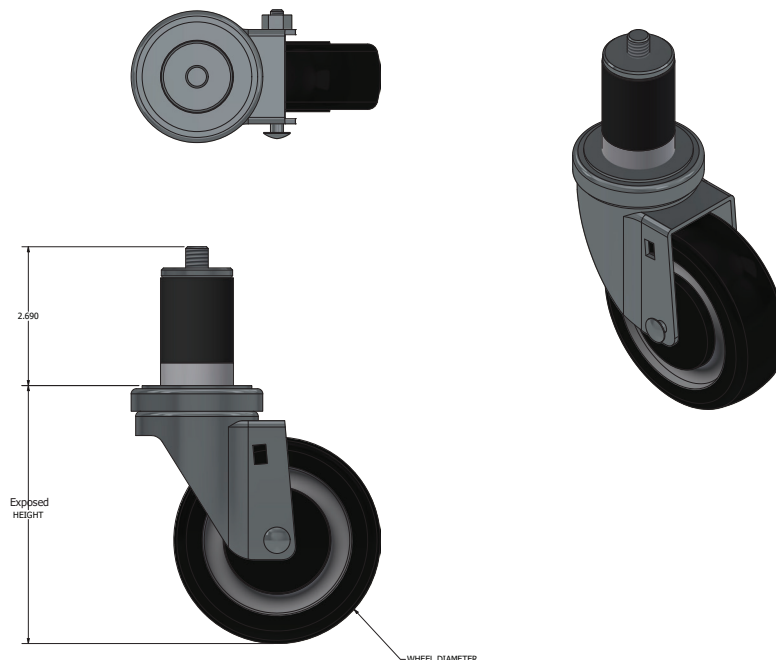

PRODUCT DATA SHEET

RESOURCES

