

SHALLOW DEPTH BASE MODEL FREEZER

Model: FA68SNBS-D

Natural Refrigerant R-290 Model

68" Shallow Depth Base Model Freezer with Drawers and 5.5" Backsplash

Heavy gauge #300 Series stainless steel top, stainless steel front and end panels, galvanized steel rear and grill and aluminum interior.



Options and Accessories

(upcharge and lead times may apply)

Stainless steel interior	Condensing unit left (standard on right)
Stainless steel back	Adjustable legs
Overshelves (single or double)	Front Breathing
Door & drawer locks	
Drawer in lieu of door section above the condensing unit*	

Consult factory for other model configurations, options and accessories.

*Drawer section above condensing unit holds (4) 1/6 pans

Continental
Refrigerator



Project Name:

Model Specified:

Location:

Item No:

Quantity:

AIA #:

SIS #:

Standard Model Features

REFRIGERATION SYSTEM

Performance rated refrigeration system

Environmentally safe R-290 refrigerant

Unique forced air design utilizes fans (approx. every 12") across the entire back of unit for even distribution of cold

Automatic, energy saving, non-electric condensate evaporator

Non-corrosive, plasticized fin evaporator coil

Expansion valve system

Easily serviceable, slide out condensing unit

CABINET ARCHITECTURE

2" non-CFC polyurethane foam insulation

Smooth, polished chrome drawer/door handles

Spring loaded, self closing door (over condensing unit)

Magnetic snap in Santoprene™ drawer/door gaskets

Stainless steel roll out drawers

Completely enclosed, vented and removable rear and side grills

5" casters

MODEL FEATURES

Electronic control, automatic electric defrost

Reversing condenser fan motor (runs for short period during startup to clear any debris)

Refrigerated section with door above the condensing unit

Field rehingeable door (over condensing unit)

¹ R-290 refrigerant meets all federal and state regulatory requirements.

NOTE: Models come standard with a door over the condensing unit. A drawer over the condensing unit is an option.

APPROVAL:

Model Specifications

DIMENSIONAL DATA

Net Capacity (cubic feet)	17.6 (498 l)
Width, Overall (inches)	68 (1732 mm)
Depth, Overall (inches) (including handles & bumpers)	31 (770 mm)
Height, Overall (inches) (including 5" casters)	40.5 (1029 mm)
Number of Drawers	4
Number of Half Doors	1
Interior Depth (inches)	24 (610 mm)
Interior Height (inches) (above condenser)	12 1/2 (318 mm)

REFRIGERANT DATA

Condensing Unit Size (H.P.)	1/2
R-290 Refrigerant Charge (oz)	5.1
Capacity (BTU per hour)*	1980

ELECTRICAL DATA

Voltage (International)	115/60/1 (220/50/1)
Total Amps (International)	8.5 (4.3)
Defrost Amps (International)	9.1 (4.6)
10 ft. Cord/Plug [attached] (International)	Yes (No)

SHIPPING DATA

Weight (pounds)	450 (222 kg)
Height - Crated (inches)	45 (1194 mm)
Width - Crated (inches)	76 (1778 mm)
Depth - Crated (inches)	39 (1111 mm)

DRAWER PAN CONFIGURATIONS

Two Tier: (1) 12 x 20 x 6 pan per drawer (supplied by others)

* Rating @ -15°F evaporator, 90°F ambient
Figures in parentheses reflect metric equivalents rounded to the nearest whole unit.



Equipped with one NEMA-5-15P Plug
(varies by country)

Model Plan Views

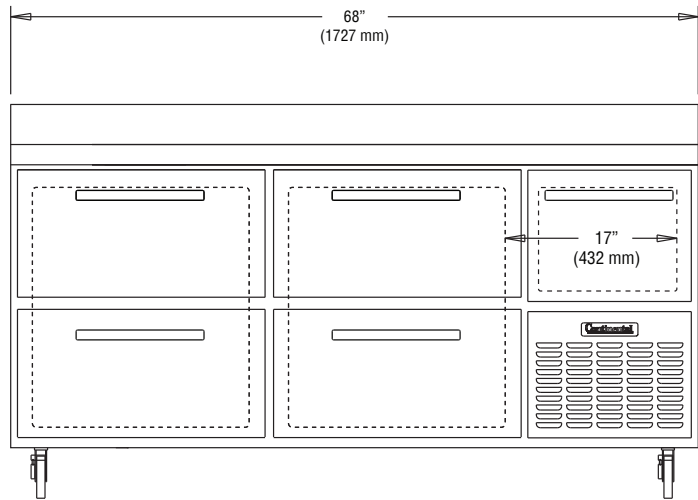

FRONT VIEW

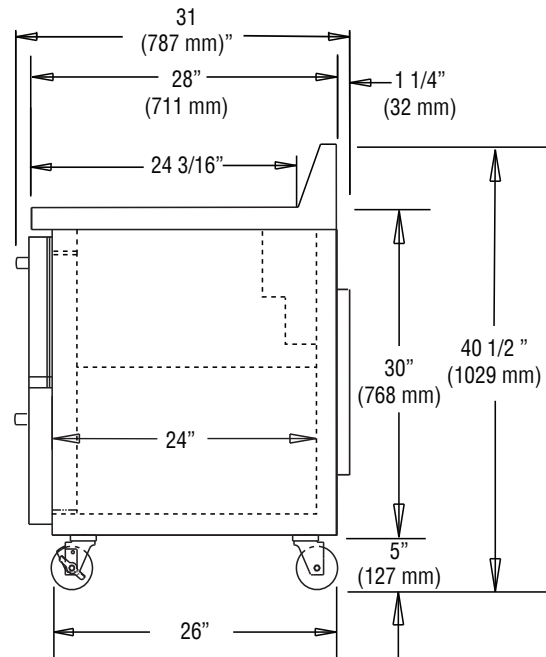

SIDE VIEW

Continental
Refrigerator

Toll-Free: 800-523-7138
Phone: 215-244-1400
Fax: 215-244-9579

539 Dunksferry Road
Bensalem, PA 19020
www.continentalrefrigerator.com

Due to our continued efforts in developing innovative products, specifications subject to change without notice.



PROUDLY
DESIGNED & ASSEMBLED
IN THE U.S.A.

© Copyright 2021. Continental Refrigerator.

REVISED: 4/30/26