

## Handler™ Series Utility Carts

### Stainless Steel Medium Duty - 500 Lb. Capacity



**Models 4411, 4422, 4444, 4459**

### The Smart Ergonomic Choice For Maneuvering In Confined Spaces

- Durable, unitized electronically welded angle leg frame
- 20-gauge stainless steel reinforced shelves
- Ergonomic vertical push handle
- Corner bumpers on front legs protects furnishings
- Sound deadening panels under shelves reduce vibrations and noise
- 500 lb. (230 kg.) load capacity

### Specifications:

Unit shall be of fully welded stainless steel unitized construction with an overall carrying capacity of 500 pounds (230 kg). Corner legs shall be of 16-gauge angle stainless steel. Shelves shall be of 20-gauge stainless steel with long shelf edges double hemmed for extra strength, and shall be electronically spot welded to upright legs at all points. One-piece tubular stainless steel ergonomic handle is shipped unassembled. Unit shall have corner bumpers mounted to front legs. Unit shall have an independent galvanized steel dolly frame fastened to the bottom with 8 screws. Four each swivel casters shall be mounted to the dolly frame.

Spec. # \_\_\_\_\_

AIA # \_\_\_\_\_

Lakeside Manufacturing, Inc.

4900 West Electric Avenue • West Milwaukee, WI 53219 U.S.A.

800-558-8565 • 414-902-6400 • Fax 414-902-6446 • info@eLakeside.com • www.eLakeside.com/foodservice

**Models**  
**4411, 4422**  
**4444, 4459**

# Handler™ Series Utility Carts

## Stainless Steel Medium Duty - 500 Lb. Capacity

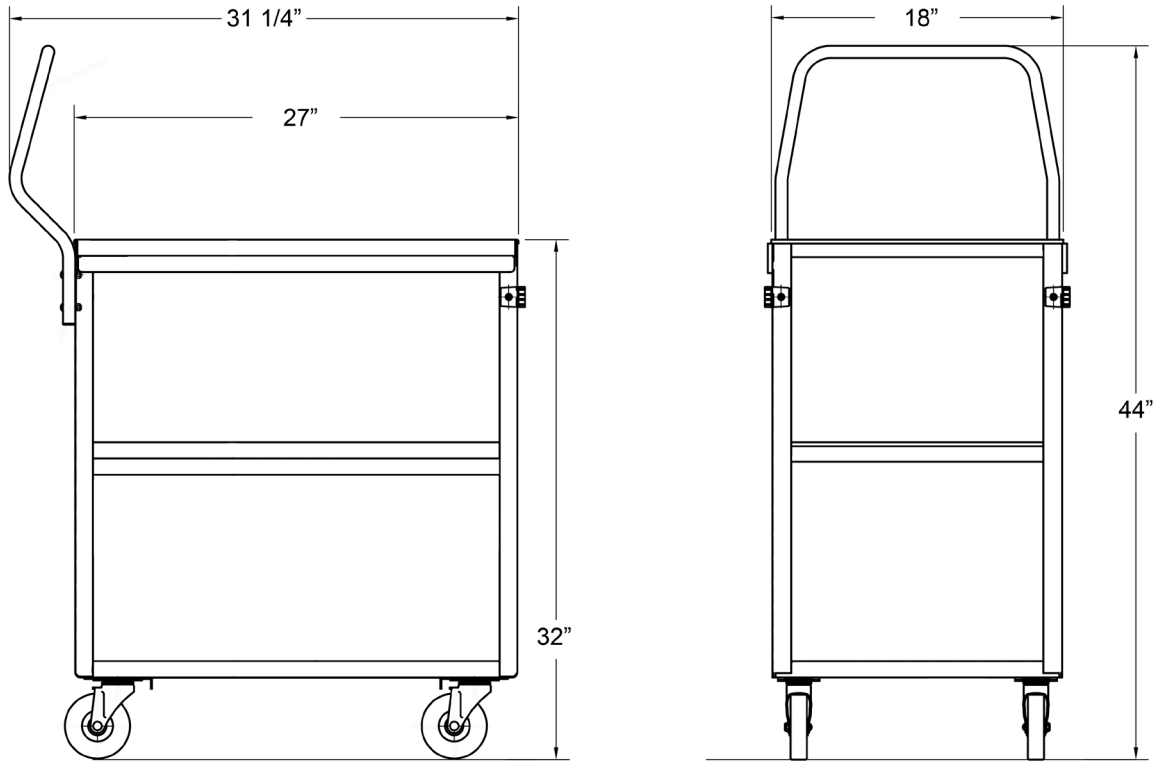

**Model 4422**

### Model Information

Model	UPS/ FedEx	Shelves		Top Shelf Height	Overall Size			Casters		Case Weight	
		Size	Clearance (C)		W	L	H*	Type	Dia.	Lbs.	(kg)
4411	Yes	15-1/2" x 24" (394 x 610)	11-1/2" (292)	31" (787)	16-3/4" (425)	27-5/8" (702)	44" (1118)	All swivel	4" (102)	39	(17.7)
4422	Yes	18" x 27" (457 x 686)	11-1/2" (292)	31" (787)	19" (483)	31" (787)	44" (1118)	All swivel	4" (102)	42	(19.1)
4444	--	21" x 35" (533 x 889)	13-1/8" (333)	36-1/4" (921)	22-3/8" (568)	39-1/4" (997)	49-1/4" (1251)	All swivel	5" (127)	68	(30.8)
4459	--	21" x 49" (533 x 1245)	13-1/8" (333)	36-1/4" (921)	22-3/8" (568)	54-1/8" (1374)	49-1/4" (1251)	All swivel	5" (127)	88	(39.9)

\* Includes vertical handle.  
 Measurements in ( ) denote metric millimeters, unless otherwise specified.

### Optional Accessories

- Perimeter shelf mounted strip bumper
- Brake casters (Set of 2)



Lakeside Manufacturing, Inc.  
 4900 West Electric Avenue • West Milwaukee, WI 53219 U.S.A.  
 800-558-8565 • 414-902-6400 • Fax 414-902-6446  
 info@eLakeside.com • www.elakeside.com/foodservice