

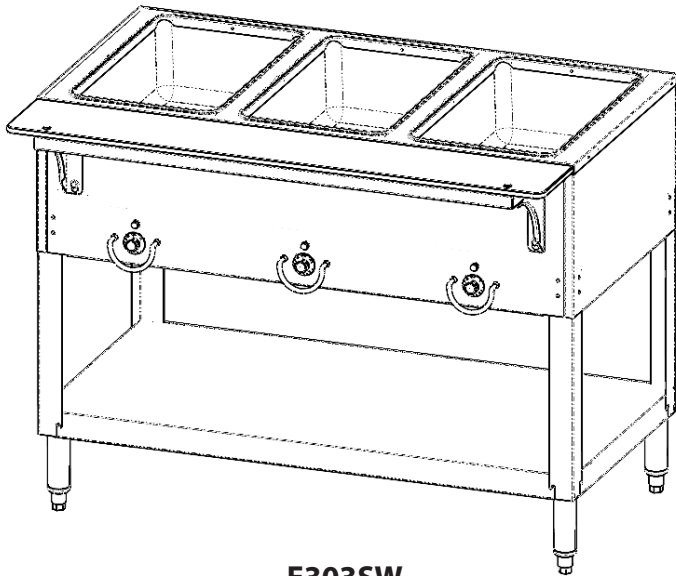

Your Solutions Partner

# Specifications

F.O.B. Sedalia, Missouri 65301



**E303SW**

### OPTIONS:

- 3-phase wiring
- Drop type brackets for cutting board
- 1200W elements
- Stainless steel feet
- Adapter plates
- Insets/Inset Covers
- Dish Shelf
- Trayslides & Workshelves
- Foodshields
- Manifolded drains with master valve

### AGENCY LISTINGS:



DUKE MANUFACTURING CO.  
 2305 N. Broadway  
 St. Louis, MO 63102  
 800.735.3853 Toll Free  
 314.231.5074 Fax  
 www.dukemfg.com

### Approval Stamp(s):

#### PRODUCT INFORMATION:

PROJECT: \_\_\_\_\_

ITEM: \_\_\_\_\_

QUANTITY: \_\_\_\_\_

#### MODEL:

#### **Aerohot™ Foodservice Hot Food Units - Electric - Sealed Wells**

- E302SW/EP302SW 2 top openings
- E303SW/EP303SW 3 top openings
- E304SW/EP304SW 4 top openings
- E305SW/EP305SW 5 top openings

#### TOP:

- 20 gauge, stainless steel
- Die-stamped openings - 11-7/8" x 19-7/8"
- Poly carving board - 7"W x 1/2" thick with 18 gauge stainless steel support shelf and die-stamped brackets

#### HEAT COMPARTMENTS:

- Insulated with fiberglass all four sides and bottom
- Stainless steel die-formed 6-1/2" deep sealed well
- Individual well drains
- Wet or dry use

#### BODY AND INTERIOR SHELF:

- 20 gauge, 430 Series stainless steel body
- 20 gauge, 430 Series stainless steel undershelf
- 430 Series stainless steel tubular legs with adjustable plastic feet

#### ELECTRICAL INFORMATION:

- 750 watt elements standard
- Wired to operate on 120, 208 or 240 Volt
- Single phase standard
- AC current
- Infinite switches standard
- Permanently wired, 6' long cord and plug provided

Specification subject to change

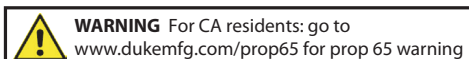

# Aerohot®

A.I.A. File No. 35-C-13

Catalog No. AFS-ELECSW

AEROHOT™ FOODSERVICE - HOT FOOD UNITS - ELECTRIC - SEALED WELLS

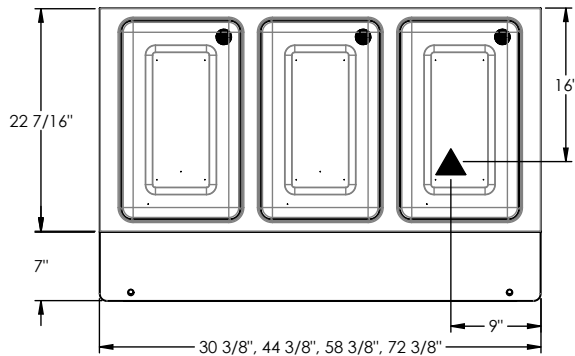

### E303SW - Shown

LEGEND	
▲	ELECTRICAL CONNECTION
"EP" = prefix on model number denotes portable unit	

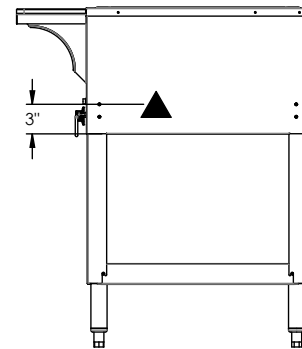
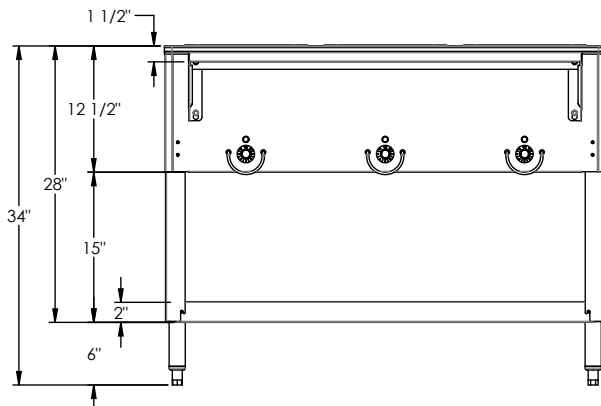

DIMENSIONS: (Consult factory for 3-phase electrical requirements and other options.)

Freight Class: 85

Model	Length		Width		Height		Top Openings	Cube ft. Crated	Weight	
	in	cm	in	cm	in	cm			lbs	kg
E302SW/EP302SW	30-3/8	77.2	22-7/16	57.1	33.38	84.8	2	23.4	81/90	36.8/40.9
E303SW/EP303SW	44-3/8	112.8	22-7/16	57.1	33.38	84.8	3	32.5	107/114	48.6/51.8
E304SW/EP304SW	58-3/8	148.3	22-7/16	57.1	33.38	84.8	4	41.5	138/144	62.7/65.5
E305SW/EP305SW	72-3/8	183.9	22-7/16	57.1	33.38	84.8	5	50.5	165/172	75.0/78.2

ELECTRICAL SPECIFICATIONS:

Cord and NEMA plug included

Model	120V 750W			208V 750W			240V 750W		
	Watt	Amps	NEMA	Watt	Amps	NEMA	Watt	Amps	NEMA
E302SW/EP302SW	1500	12.5	5-15	1500	7.2	6-20	1500	6.3	6-20
E303SW/EP303SW	2250	18.8	L5-30	2250	10.8	6-20	2250	9.4	6-20
E304SW/EP304SW	3000	25.0	5-50	3000	14.4	6-20	3000	12.5	6-20
E305SW/EP305SW	3750	31.3	5-50	3750	18.0	L6-30	3750	15.6	L6-30

Model	120V 1200W			208V 1200W			240V 1200W		
	Watt	Amps	NEMA	Watt	Amps	NEMA	Watt	Amps	NEMA
E302SW/EP302SW	2400	20	L5-30	2400	11.5	6-20	2400	10	6-20
E303SW/EP303SW	3600	30	5-50	3600	17.3	L6-30	3600	15	6-20
E304SW/EP304SW	N/A	N/A	N/A	4800	23.1	L6-30	4800	20	L6-30
E305SW/EP305SW	N/A	N/A	N/A	6000	28.9	6-50	6000	25	6-50

CONTACT FACTORY: Electric values & plug configurations change for 3 phase or when adding electric options.



**Duke Manufacturing Co.**  
2305 N. Broadway  
St. Louis, MO 63102

Phone: 314-231-1130  
Toll Free: 1-800-735-3853  
Fax: 314-231-5074

[www.dukemfg.com](http://www.dukemfg.com)

Printed in U.S.A.  
© 2025, Duke Manufacturing Co.