

SMSL-12

12" MANUAL COMMERCIAL MEAT SLICER



FEATURES:

- Easy to clean aluminum base
- Powerful 1/2 HP blade motor
- Compact profile with ergonomic body design
- Top mount knife sharpener included
- Large thickness adjustment knob
- Smooth easy clean surfaces for day end cleaning
- Rubber shock absorbing padded feet
- Clear rubber covered durable on off switch
- Precise thickness adjustment to 9/16 inch thickness
- Underside protected with thick plastic cover
- Fan cooled motor with capacitor
- Stainless steel knife blade
- Ideal for cold meat, ham, fish, and cheese
- Removable carriage for easy cleaning
- Belt driven system
- Units have overload protection and a manual reset button
- Grounded 5.9' 120V power cord attached

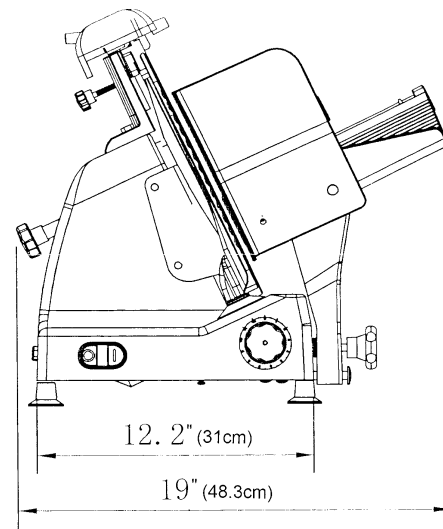
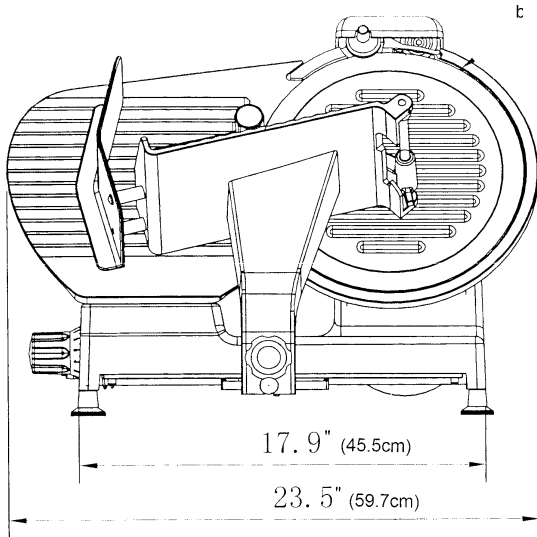

12" MANUAL COMMERCIAL MEAT SLICER

MODEL	BLADE DIAMETER	CUTTING THICKNESS	TRAY SIZE	OVERALL DIMENSIONS (WxDxH)	AMPS	HP	INPUT VOLTAGE	PHASE	WATT	SHIPPING DIMENSION (WxDxH)	NW (lbs.)	GW (lbs.)
SMSL-12	12"	0-9/16"	10.24" x 10.01"	23.6" x 19.3" x 18.1"	1.74	1/2	120V	1	380	25.8" x 21.5" x 18.1"	46.96	52.69

In the pursuit of a better product, durability and performance. SATURN reserves the right to change specifications, materials and design without further notice.