



**FOOD EQUIPMENT**

*SERVING THE FOOD INDUSTRY SINCE 1951*

# 16" WOK RANGE - PROPANE GAS

Items: 47687 | Model: CE-CN-WOK16 LP



## PREPARE YOUR STIR FRY DISHES WITH OMCAN'S 16" WOK RANGE!

Ideal for making wok dishes such as: stir fry dishes, sauteed vegetables, and much more. The compact size saves on space in your kitchen.



**WARRANTY**  
PARTS AND LABOR



Authorized Dealer

# FOOD EQUIPMENT

## 16" WOK RANGE



### TECHNICAL DRAWINGS & DIMENSIONS

\*measurements in diagrams are in mm

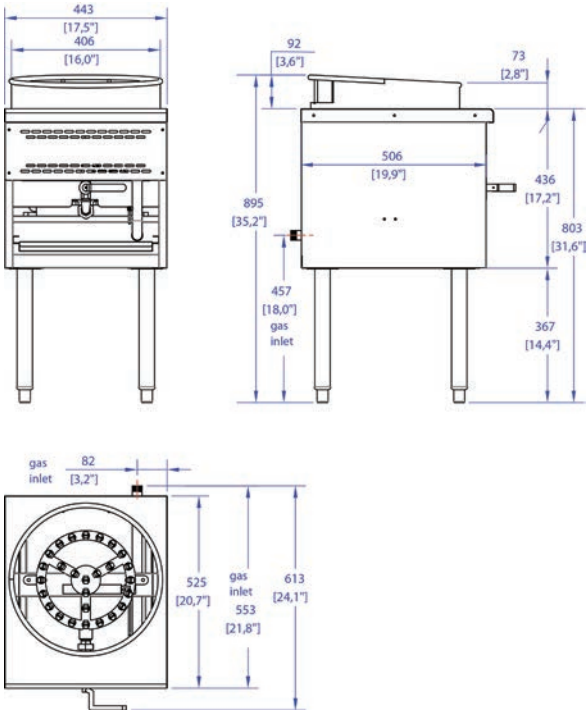

### TECHNICAL SPECIFICATIONS

Item	47687
Model	CE-CN-WOK16 LP
Number Of Burners	1
BTU	125,000
Pre-Heat Time	5 minutes
Gas Type	Propane Gas
Cooking Area	16" diameter
Dimensions	17.5" x 24.1" x 35.2"/443 x 613 x 895 mm
Gross Dimensions	18.1" x 22.8" x 22.2"/460 x 580 x 565 mm
Weight	68 lbs. / 31 kg
Gross Weight	84 lbs. / 38 kg
Conversion Kit Included	No

### FEATURES:

- Stainless steel front and cabinet base
- Jet burner with an adjustable gas valve
- Pilot ignition
- 16" wok ring, making stir-frying quick and easy
- Propane gas, 3/4" rear gas connection
- 5 minute pre-heat time



**WARRANTY**  
PARTS AND LABOR



Manufactured for commercial installation only, not intended for home use.

## OMCAN INC.

Telephone: 1-800-465-0234  
 Fax: (905) 607-0234  
 Email: sales@omcan.com  
 Website: www.omcan.com



Follow us to keep up to date with the latest news and offers



2017E&OE