

# SEAGATE

## REFRIGERATED CHEF BASES

SCBR-36, SCBR-50, SCBR-62, SCBR-74

Achieve efficiency while giving your kitchen the ability to store food pans and expand cook top space with the help of SEAGATE Refrigerated Chef Bases.

Keeping the optimal temperature range of 33° - 40°F for your products is made simple with the electronic thermostat and digital LED display. The automatic defrost system ensures that foods remain at optimal quality preventing condensation from damaging the product.

Providing durability and a smooth surface to wipe spills and messes away easily, the stainless steel construction along with the raised marine edge makes clean-up a simple task to complete. Eco friendly R290 refrigerant keeps items cool while helping to reduce your environmental impact.

Create a smarter, more efficient kitchen with a SEAGATE Refrigerated Chef Base.

SEAGATE, it means a great deal.

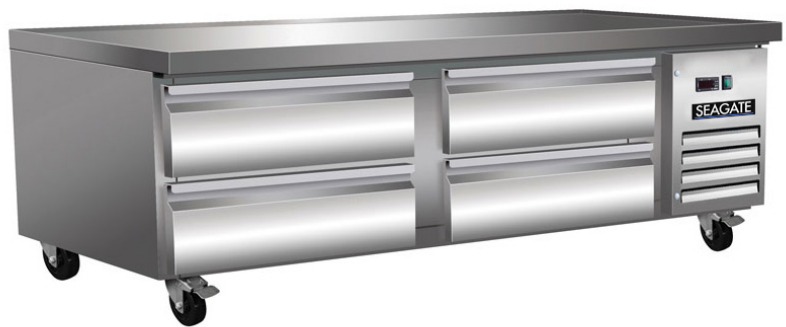

## STANDARD FEATURES

- CFC free refrigerant and foam insulation
- Electronic thermostat and digital LED temperature display
- Auto defrosting and auto evaporation of condensation water
- Raised marine edge contains spills
- R-290 Natural refrigerant
- Temperature: 33 to 40°F (0.5 to 4°C)
- Stainless steel exterior
- Aluminum back panel and interior
- Easy to mount 4" casters (two lockable in front) are standard with all units
- Side mounted, self-contained refrigeration system
- Magnetic gasket can be replaced without any tools
- 4" PC pans **not** included.

\*Note: this unit **cannot** accommodate 6" PC pans\*

AVAILABLE EXCLUSIVELY AT BURKETT RESTAURANT EQUIPMENT & SUPPLIES | [BURKETT.COM/BRAND/SEAGATE](http://BURKETT.COM/BRAND/SEAGATE) | 419-720-8190



# SEAGATE



SCBR-36



SCBR-50

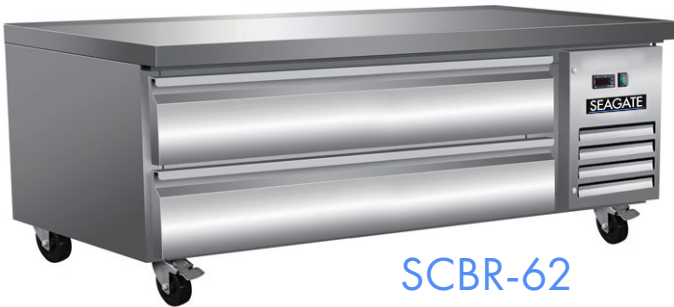

SCBR-62

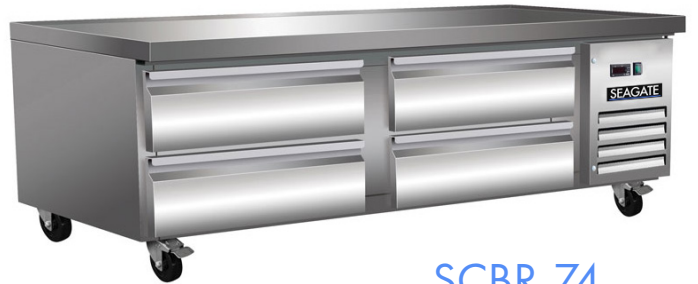

SCBR-74

## SPECIFICATIONS

MODEL NUMBER	SCBR-36	SCBR-50	SCBR-62	SCBR-74
DRAWERS	2	2	2	4
STORAGE CAPACITY (cu. ft.)	5.1	6.5	8.7	10.8
TEMPERATURE RANGE	33°F to 40°F	33°F to 40°F	33°F to 40°F	33°F to 40°F
H/P	1/3	1/3	1/3	1/3
AMPS	2.1	2.1	2.1	2.1
VOLTAGE	115/60/1	115/60/1	115/60/1	115/60/1
EXTERIOR DIMENSIONS (W x D x H)	38" x 31.9" x 26"	50" x 31.9" x 26"	62" x 31.9" x 26"	74" x 31.9" x 26"
INTERIOR DIMENSIONS (W x D x H)	21.3" x 26.8" x 13.9"	28.2" x 26.8" x 13.9"	40.2" x 26.8" x 13.9"	52.2" x 26.8" x 13.9"
PLUG TYPE	NEMA 5-15P	NEMA 5-15P	NEMA 5-15P	NEMA 5-15P
WEIGHT (lbs)	205	260	302	353

## WARRANTY

2-YEAR PARTS & LABOR  
5-YEAR COMPRESSOR

Specifications are subject to change without notice

AVAILABLE EXCLUSIVELY AT BURKETT RESTAURANT EQUIPMENT & SUPPLIES | BURKETT.COM/BRAND/SEAGATE | 419-720-8190



SCBR-36  
FRONT

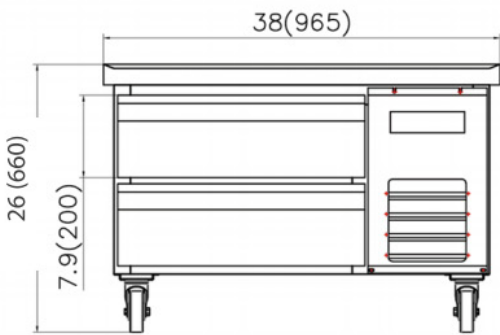

SCBR-36  
SIDE

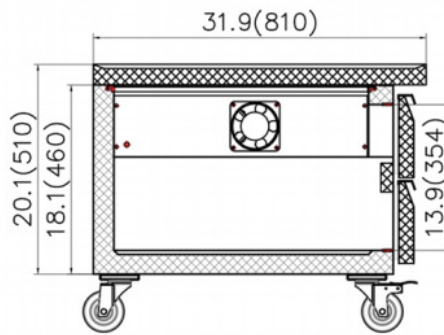

SCBR-36  
TOP

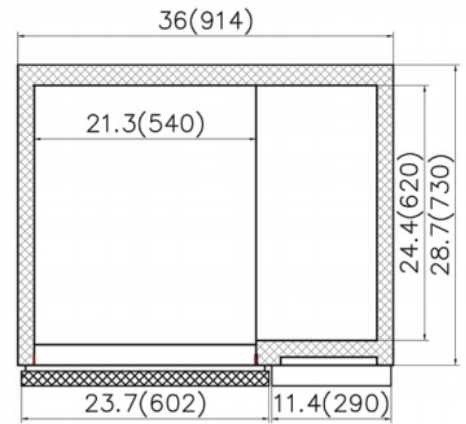

SCBR-50  
FRONT

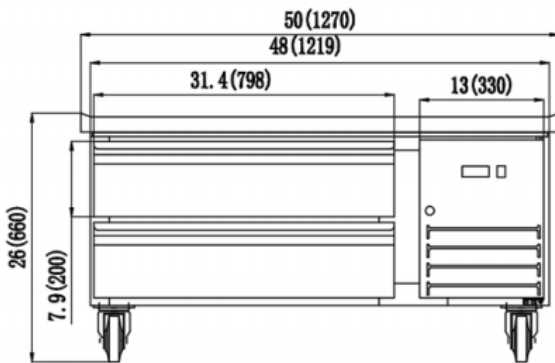

SCBR-50  
SIDE

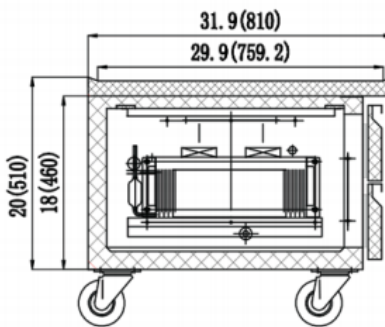

SCBR-50  
TOP

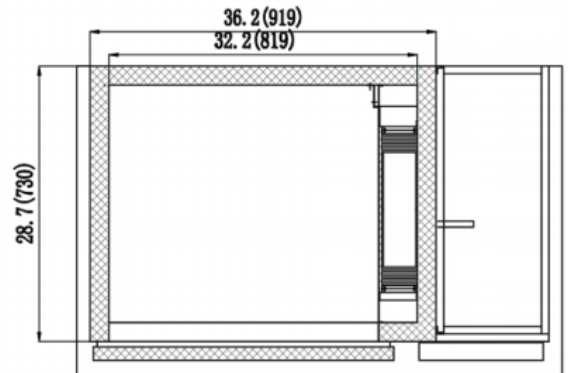

SCBR-62  
FRONT

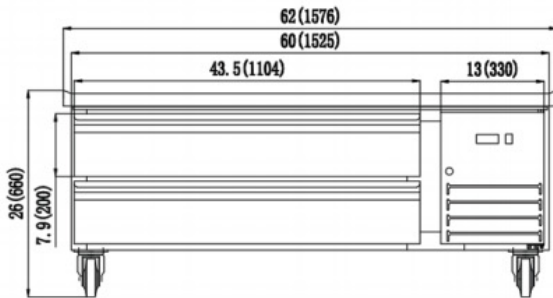

SCBR-62  
SIDE

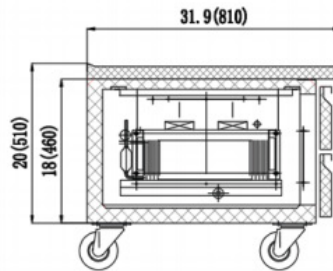

SCBR-62  
TOP

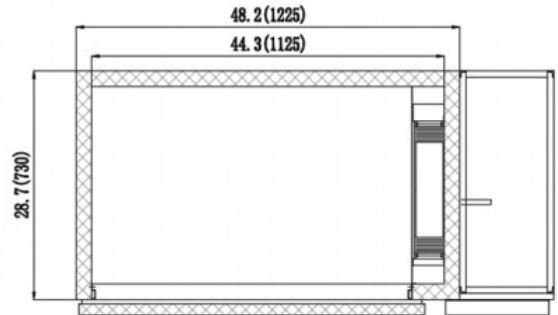

SCBR-74  
FRONT

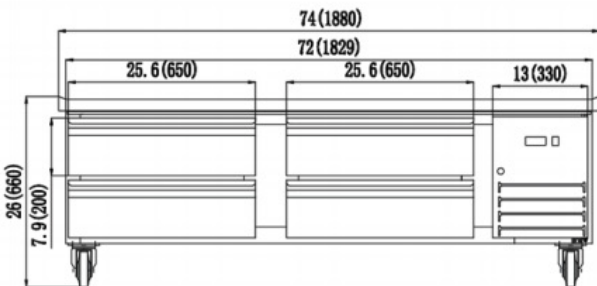

SCBR-74  
SIDE

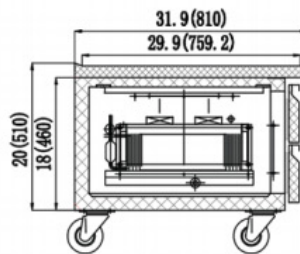

SCBR-74  
TOP

