



Project \_\_\_\_\_  
 AIA # \_\_\_\_\_ SIS # \_\_\_\_\_  
 Item # \_\_\_\_\_ Quantity \_\_\_\_\_ C.S.I. Section 114000

## R Series

52" Wide Pass-Thru Refrigerator  
 Solid Door, 32" Deep, Self-Contained



### STANDARD PRODUCT FEATURES

- Stainless Steel Exterior & Interior
- Variable Speed Compressor Adapts to the Specific Work Environment
- Traulsen's Smart Control™ with LED Display
- StayClear™ Condenser Coil
- Balanced, Self-Contained Refrigeration System Using R290 Refrigerant
- Rear Biased Return Air Duct
- Full or Half-Height Stainless Steel Doors with Locks
- Anti-Condensate Door Perimeter Heater
- Self-Closing Doors with Stay Open Feature
- Standard Door Hinging F & R: 232NP = Left/Right (other hings available)
- Automatically Activated LED Lights
- Stainless Steel Breaker Caps
- Three Adjustable, Coated Wire Shelves Per Section, Supported on Shelf Pins (factory installed)
- Automatic Non-Electric Condensate Evaporator
- Magnetic Snap-In EZ-Clean™ Door Gaskets
- Thermostatic Expansion Valve Metering Device
- Stainless Steel One-Piece Louver Assembly
- 9' Cord & Plug Attached
- Set of (4) 6" High Adjustable Stainless Steel Legs

### ACCESSORIES & OPTIONS

- SmartConnect™ Monitoring App with Wi-Fi Connectivity
- Accommodates EZ-Clean™ Tray Racks
- #1 Type Trayslides to Accommodate either (1) 18" x 26" or (2) 14" x 18" Pans
- #4 Type Trayslides to Accommodate 18 to 19 Levels for 18" x 26" Pans
- Universal Type Trayslides to Accommodate (1) 18" x 26" or (2) 14" x 18" Sheet Pans, or (2) 12" x 20" Steam Table Pans; (4) Pairs per Half Section
- Additional Coated Wire or Optional Stainless Steel Shelves
- Locking Hasps (padlocks supplied by others)
- Optional 208-230/115/60/1 or 208-230/60/1 Voltage
- Kool Klad™ Exterior Laminate Decor
- Set of (4) 4 1/8" or 6" High Casters in Lieu of Legs
- Other Support Options: 4 1/2" High Base or 6" High Kickplate (for use with standard legs)
- Clear Glass Door(s) in Place of Solid Door(s)



Models listed to the applicable UL, CSA and NSF standards by an approved NRTL. Consult the factory or unit data plate for additional information.

### AVAILABLE CONFIGURATIONS

<b>R Series Models</b>	<b>Door(s)</b>
RHT232NP/UT-FHS	Full Height Solid
RHT232NP/UT-HHS	Half Height Solid



ENERGY STAR® Listed Commercial Refrigerator  
 For full listing visit [energystar.gov](http://energystar.gov)

\*Remote application without R-290 refrigerant available, see form TR35837 for details.

- GUARANTEED FOR LIFE CAM-LIFT HINGES
- GUARANTEED FOR LIFE HORIZONTAL WORKFLOW DOOR HANDLES

Approved by \_\_\_\_\_ Date \_\_\_\_\_ Approved by \_\_\_\_\_ Date \_\_\_\_\_

### MODELS:

RHT232NPUT-HHS, RHT232NPUT-FHS

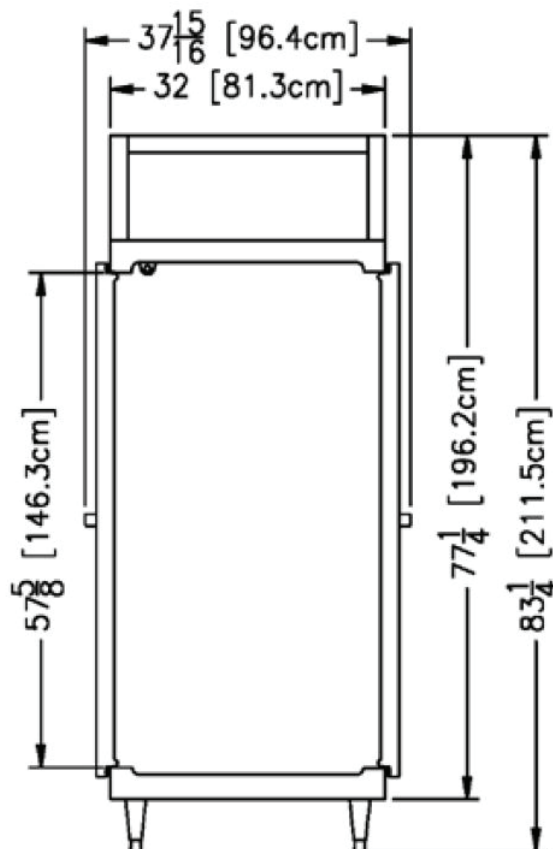
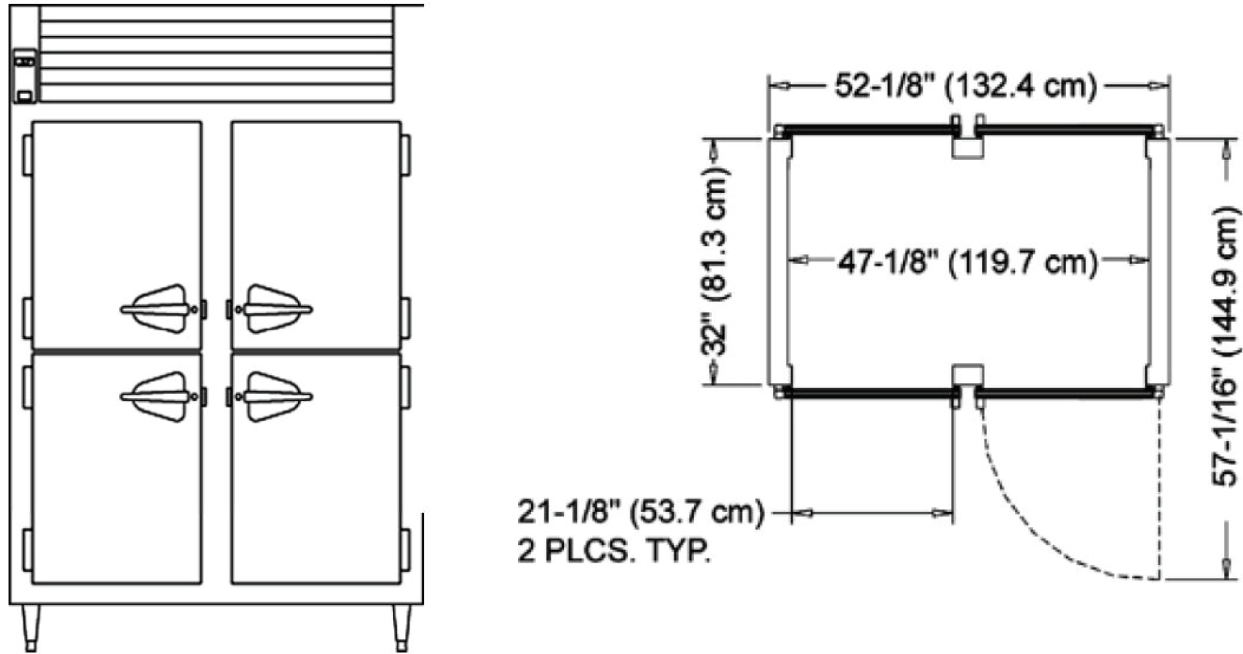

> CAD and/or Revit Files Available

<https://traulsen.klccad.com/>



**MODELS:**

RHT232NPUT-HHS, RHT232NPUT-FHS

MODELS	RHT232NPUT
<b>DIMENSIONAL DATA</b>	
Net capacity cu. ft.	48.87 (1383.8 cu l)
Length - overall in.	52 1/8" (132.4 cm)
Depth - overall in.	37 15/16" (96.4 cm)
Depth - over body in.	32" (81.3 cm)
Depth - door open 90° in.	57 1/16" (144.9 cm)
Clear door width in.	21 1/8" (53.6 cm)
Clear half-door height in.	27 1/2" (69.9 cm)
Clear full-door height in.	57 5/8" (146.3 cm)
Height - overall on 6" legs <sup>2</sup>	83 1/4" (211.5 cm)
No. Standard Shelves	6
Shelf area sq. ft. <sup>3</sup>	25.83 (2.4 sq. m)
<b>ELECTRICAL DATA</b>	
Voltage   Plug	115/60/1   NEMA 5-15P
Full Load Amperes   KWH/24HR <sup>4</sup>	7.6   2.75 (FHS), 2.74 (HHS)
<b>REFRIGERATION DATA</b>	
Refrigerant	R290
Refrigerant Charge Amount oz.	4.8 (136 g)
BTU/HR   H.P. <sup>1</sup>	2875   1/2 HP
<b>SHIPPING DATA</b>	
Length - Crated in.	62" (157.5 cm)
Width - Crated in.	42" (106.7 cm)
Height - Crated in.	85" (215.9 cm)
Volume - Crated cu. ft.	128.09 (3627.1 cu l)
Weight - Crated lbs.	738 (334.8 kg)

NOTES: Figures in parentheses reflect metric equivalents.

1. Based on a 90°F ambient and 20°F evaporator.
2. 12" Top clearance preferred for optimum performance & service access.
3. Area of standard shelf compliment only, does not include storage area of additional shelves or available on cabinet bottom.
4. KWH/24HR = Kilowatt usage per 24 hours

**EQUIPMENT SPECIFICATIONS**

**CONSTRUCTION, HARDWARE, INSULATION**

The interior is made from stainless steel and the cabinet exterior front, one piece sides, louver assembly, doors and door liners are constructed of heavy gauge stainless steel. The exterior cabinet top and bottom are constructed of heavy gauge galvanized steel. Included is a set of four adjustable 6" stainless steel legs.

Doors have removable plug cylinder locks & guaranteed for life gravity action, self-closing cam-lift hinges with a stay-open feature. An external switch is included to activate interior LED lighting. The gasket design simplifies cleaning & enhances longevity. Anti-condensate heaters are located behind each door opening.

The unit has seamless, polished metal corners & guaranteed for life workflow door handles mounted horizontally over recess in door which limits protrusion from door face into aiseways. The cabinet is insulated with high density, non-CFC, foamed in place polyurethane.

**SELF-CONTAINED REFRIGERATION SYSTEM**

The unit uses a top-mounted, balanced system located behind the one piece louver assembly. The R290 refrigerant is environmentally friendly & has a low GWP. It features a finless StayClear™ condenser, thermostatic expansion valve, air-cooled, hermetic variable speed compressor, plenum effect blower coil, large, high humidity evaporator coil outside the food zone & a top-mounted non-electric condensate evaporator.

The biased return air duct protects against warm kitchen air, ensuring consistent temperatures & efficient operation. Operating temperatures are 34-38°F. A 9' cord and plug are provided.

**CONTROL**

Traulsen's Smart Control™ features advanced control algorithms & sophisticated diagnostic capabilities to optimize performance. Utilizing smart sensors, it adapts the operation of the refrigeration system to a variety of environments & usage patterns. The Smart Control™ also offers a complete set of visual alarms designed to alert the user to critical events such as power outages or a prolonged door opening. In the event of an alarm, a dedicated Alarm LED will illuminate, informing the user of the critical event and duration.

**INTERIOR**

The interior includes three factory installed pin-mounted, full-width coated wire shelves per section with no large gaps. Each shelf can support up to 225 lbs. Factory installed optional trayslides may be purchased in combination with, or in lieu of these.

**WARRANTY**

Both a six year parts & labor warranty and a seven year compressor warranty (self-contained models only) are provided standard.

When ordering please specify: Voltage, Hinging, and Options

Equipped with one NEMA 5-15P Plug 