



ELECTRIC FRYER - 40 LBS

IMPERIAL



IFS-40-E IFS-40-EU



IFS-40-EU
Tilt-up elements provide full access to the frypot for cleaning.



IFS-40-E
Immersed element models are the lowest cost alternative for electric fryers.

ELECTRIC ELEMENTS

- Elements are located inside the stainless steel frypot, below the fry zone.
- Element output is 14 KW.
- Two elements styles are available, immersed elements are the most economical, the tilt-up elements offer complete access to the frypot for cleaning.
- Direct heat-to-element contact heats oil quickly resulting in less absorption and better tasting food.
- Snap acting electronic thermostat has a 200°F - 400°F. (93°C - 204°C) temperature range that extends oil life and produces a uniformly cooked product.

STAINLESS STEEL FRYPOTS

- Large 14" x 14" (356 x 356 mm) frying area.
- Frypot sides are robotically welded stainless steel to virtually eliminate leaks.
- Fine mesh wire crumb is included.
- Deep drawn bottom facilitates draining, slants toward the drain.
- 1-1/4" (32 mm) full port drain valve empties frypot quickly and safely.
- Two large, nickel-plated fry baskets with vinyl coated, heat protection, handles are included.
- Basket hangers are stainless steel.

EXTERIOR

- Stainless steel front, door, sides, basket hanger and frypot.
- Welded and polished stainless steel seams.
- Full heat shield protects control panel.
- Full bottom chassis provides structural support. Plate mounted 6" (152 mm) heavy duty stainless steel legs or optional casters assure secure support.
- One year parts and labor warranty. Limited warranty on frypot, stainless steel frypot is five years pro-rated.

LARGE COOL ZONE

- Captures and holds particles out of the fry zone
- Reduces taste transfer

IMPERIAL

1128 Sherborn Street | Corona, CA 92879 | 800.343.7790 | imperialrange.com | imperialsales@imperialrange.com

© 2026 Imperial Commercial Cooking Equipment Imperial reserves the right to change specifications at any time without prior notice and without any obligation for past or future equipment purchases. Visit www.imperialrange.com for specification updates.



ELECTRIC

FRYERS - 40 LBS.

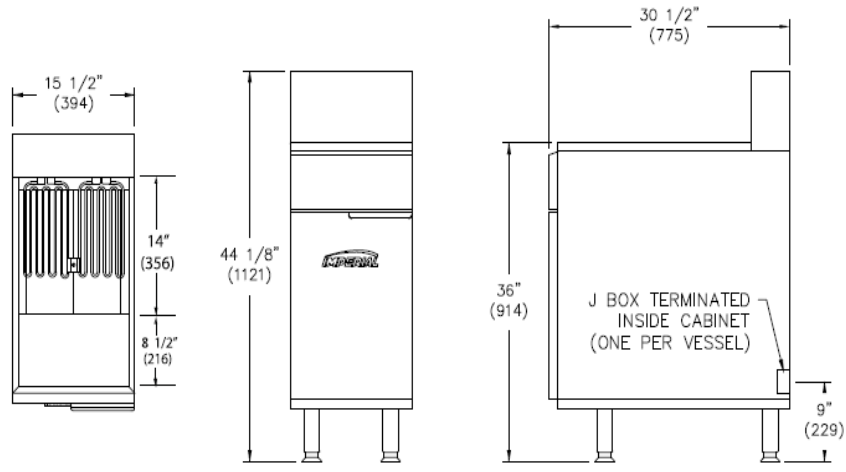

** ONE J BOX PER VESSEL **

MODEL	OIL CAPACITY	OVERALL DIMENSIONS			CRATED DIMENSIONS			TOTAL OUTPUT	SHIP WEIGHT (KG) LBS
		WIDTH	HEIGHT	DEPTH	WIDTH	HEIGHT	DEPTH		
IFS-40-E	40 LBS (18 L)	15 1/2" (394)	44 1/8" (1121)	30 1/2" (775 mm)	18 (457)	34" (864)	35" (889 mm)	14 KW	(100) 221
IFS-40-EU	40 LBS (18 L)	15 1/2" (394)	44 1/8" (1121)	30 1/2" (775 mm)	18 (457)	34" (864)	35" (889 mm)	14 KW	(100) 221
IFS-DS	N/A, drain station	15 1/2" (394)	44 1/8" (1121)	30 1/2" (775 mm)	18 (457)	34" (864)	35" (889 mm)	N/A	(60) 130

Notes: "DS" drain station with storage cabinet, no filter. Includes a 4" (102 mm) deep stainless steel drain pan.

ELECTRICAL REQUIREMENTS

MODEL	TOTAL KW	VOLTS	PHASE	AMPS
IFS-40-E / IFS-40-EU	14	208	1	68
	14	240	1	59
	14	208	3	39
	14	240	3	34
IFS-40-EU	14	480*	3	17

*Additional charge



MADE IN USA

CLEARANCE REQUIREMENTS

For use only on non-combustible floors. Legs or casters are required for non-combustible floors; or 2" (51 mm) overhang is required when curb mounted. Provide 0" clearance from non-combustible surfaces and 6" (152 mm) from combustible surfaces.

OPTIONS AND ACCESSORIES

- Fryer drain station with storage cabinet
- Heat lamp for drain station
- Stainless steel joiner strips
- 20-1/2" (521 mm) high backguard, no shelf
- Automatic basket lifts
- Computer controls
- Catering package for easy transporting
- Extra fry baskets with vinyl coated handles
- Fryer Tip Brush
- Goofer Declogger Rod
- Sediment Scooper
- 6" (152 mm) casters



1128 Sherborn Street | Corona, CA 92879 | 800.343.7790 | imperialrange.com | imperialsales@imperialrange.com

©2026 Imperial Commercial Cooking Equipment Imperial reserves the right to change specifications at any time without prior notice and without any obligation for past or future equipment purchases. Visit www.imperialrange.com for specification updates