

Mobile Cold Food Counter

Standard Features

FRAME: Featuring frameless construction utilizing 16 gauge stainless steel formed end panels with top and bottom horizontal members of 16 gauge stainless steel.

CASTERS: Heavy duty 5" diameter plate casters with gray rubber tires. Brake models to be supplied on all casters.

TOP: 14 gauge stainless steel with 2" turndown on all sides and sound deadening applied between top and frame.

FRONT BODY PANEL: Removable stainless steel or plastic laminate front panel.

UNDERSHELF: 18 gauge stainless steel with 18" high ends and 4" high back. Undersheff is held back 6" from front panel forming a utility chase for plumbing and electrical services.

COLD FOOD UNITS: Mechanically cooled stainless steel cold pan 9" deep. Removable pan rail set down 3" from top. Pans are recessed 3". Bottom slopes to 1" drain. Self contained R-404A condensing unit.

FRAME: Featuring frameless construction utilizing 16 gauge stainless steel formed end panels with top and bottom horizontal members of 16 gauge stainless steel.

CASTERS: Heavy duty 5" diameter plate casters with gray rubber tires. Brake models to be supplied on all casters.

TOP: 14 gauge stainless steel with 2" turndown on all sides and sound deadening applied between top and frame.

FRONT BODY PANEL: Removable stainless steel or plastic laminate front panel.

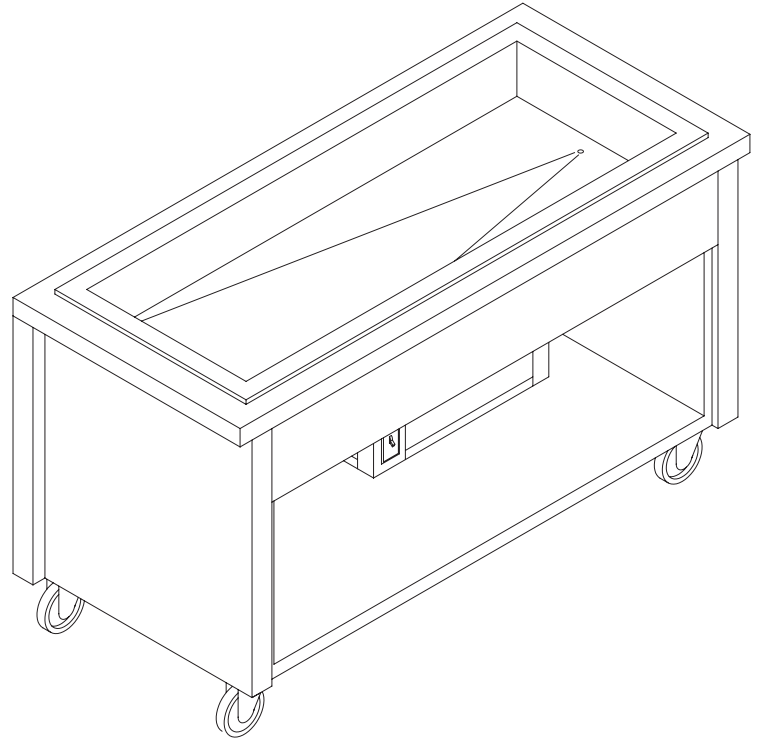

MODEL	LENGTH	PAN CAPACITY	HP	VOLTS	PHASE	NEMA AMPS	APPROX. CORD/CAP	SHIP WEIGHT
MCT-CF2	36"	2	1/4	120	1	10.0	NEMA 5-15P	390 lbs
MCT-CF3	50"	3	1/4	120	1	10.0	NEMA 5-15P	460 lbs
MCT-CF4	64"	4	1/4	120	1	10.0	NEMA 5-15P	530 lbs
MCT-CF5	78"	5	1/3	120	1	10.0	NEMA 5-15P	610 lbs
MCT-CF6	92"	6	1/3	120	1	10.0	NEMA 5-15P	680 lbs



Mobile Cold Food Counter

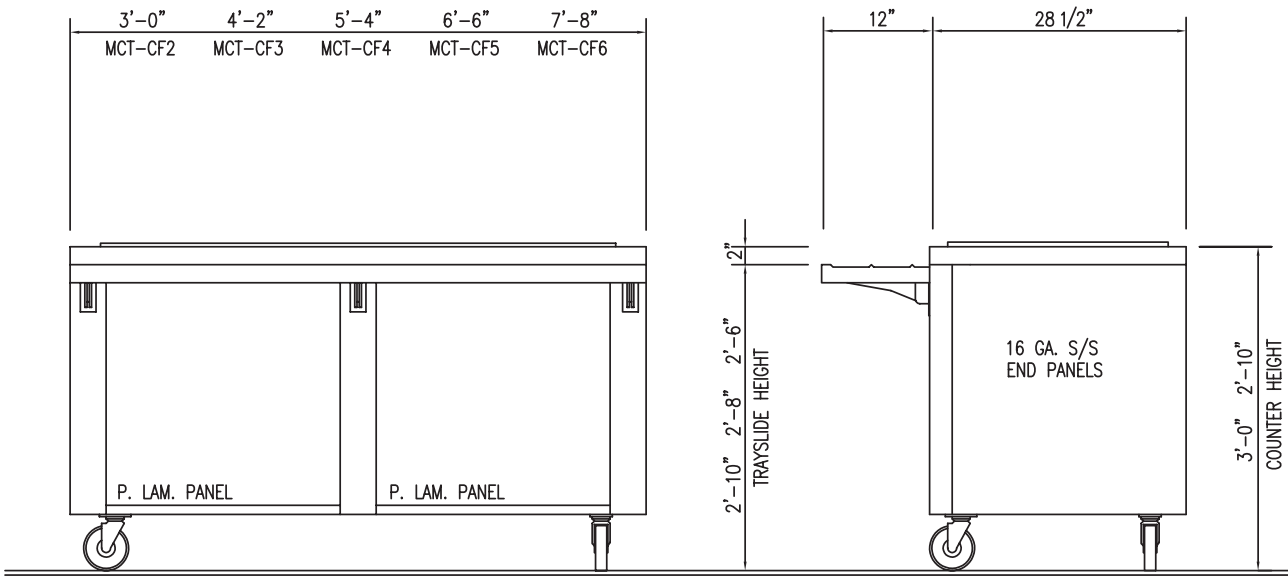

Optional Features

FRONT BODY PANEL: Ceramic tile front panel.

TRAYSLIDE: Stainless steel or Corian® trayslide mounted on fold down brackets. Stainless steel tubular trayslide also available, on fold down brackets.

WORKSHELF: 16 gauge stainless steel 8" wide shelf mounted at rear on fold down brackets.

PLATESHELF: 16 gauge stainless steel 8" wide shelf mounted at rear on fold down brackets

FLUORESCENT LIGHT: Pre-wired fluorescent light fixture with safety shields and toggle switch.

ADDITIONAL WARRANTY: Additional 12 month limited warranty on parts and labor.

SERVING SHELF: 16 gauge stainless steel or Corian® single serve with 1 1/2" turndown on all sides. Support post of 1 1/4" 18 gauge stainless. Includes sneeze-guard of 3/8" thick high grade Lexan® with polished edges.

DISPLAY SHELF: 16 gauge stainless steel or Corian® two-tier shelf with 1 1/2" turndown on all sides. Support post of 1 1/4" 18 gauge stainless. Includes sneeze-guard of 3/8" thick high grade Lexan® with polished edges.

BUFFET SERVICE: Dual service shelf with dual service sneeze-guard of 3/8" thick high grade Lexan® with polished edges.

OPTIONAL COUNTER/TRAYSLIDE HEIGHT:
 Elementary schools - 34" counter / 30" trayslide
 Middle School - 34" counter / 32" trayslide
 High School - 36" counter / 34" trayslide

For options / accessories / modifications not shown, please contact factory.



Mod-U-Serve reserves the right to modify specifications or discontinue models without notice or incurring obligation.



2320 Peyton Houston, Texas 77032
 Phone 281-442-8001 Toll Free: 888-955-5463 Fax: 281-442-3351 www.mod-u-serve.com