

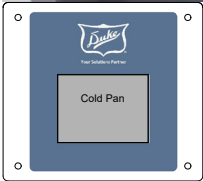

Your Solutions Partner

# Specifications

F.O.B. Sedalia, Missouri 65301

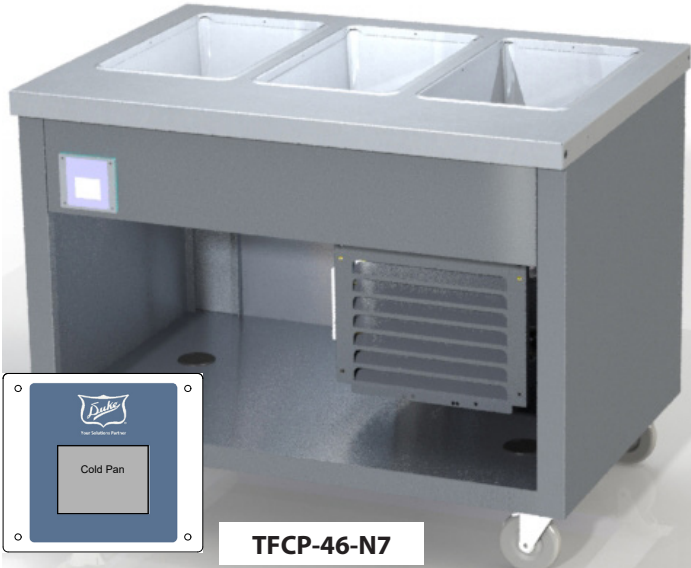

TFCP-46-N7

### OPTIONS:

- Internal Locking device
- 14 gauge tops
- Condensate evaporator
- False Bottom
- Foodshields
- Trayslides
- 6" adjustable Stainless steel legs
- 8' or 10' cord and plug
- Veneered plastic laminate panels on body
- Powder coat paint colors
- Kickplates SS & PG
- 34" ADA height (units finish at 33.5"). Adjustable height casters with 5/8" adjustability allow leveling to 34".

### AGENCY LISTINGS:



DUKE MANUFACTURING CO.

2305 N. Broadway

St. Louis, MO 63102

800.735.3853 Toll Free

314.231.5074 Fax

www.dukemfg.com

SS-1259 Thurmduke SS Cold Mech N7

### Approval Stamp(s):

### PRODUCT INFORMATION:

PROJECT: \_\_\_\_\_

ITEM: \_\_\_\_\_

QUANTITY: \_\_\_\_\_

MODEL:

### Thurmduke™ Serving Systems - Cold Pan

### Mechanically Cooled - Meets NSF Standard 7 - 8"

### Deep

- TFCP-32-N7 2 Sections 32" length unit
- TFCP-46-N7 3 Sections 46" length unit
- TFCP-60-N7 4 Sections 60" length unit
- TFCP-74-N7 5 Sections 74" length unit
- TFCP-88-N7 6 Sections 88" length unit

### TOP:

- 16 gauge, 300 Series stainless steel
- Edges flanged down 2" at 90° - all four sides
- Inside edges flanged down 90° against liner

### COLD PAN LINER:

- 300 Series stainless steel
- Accepts up to 6" deep food pans
- Insulated on all four sides and bottom
- Drain for each well manifolded to one location

### REFRIGERATION:

- 120 VOLT - 1 Phase - 448a refrigerant
- Condensing unit below top on operator's right
- Stainless steel louvered grille for air circulation
- 6' electric cord and plug - NEMA 5-15
- Necessary controls for operation

### BODY:

- Choice of available powder coat paint colors
- Stainless steel body
- Operator's side open to bottom shelf
- Customer side and ends fully enclosed
- Bottom shelf paint grip or stainless steel to match body

### CONTROL:

- Touchscreen control left justified in apron
- Simple touch screen control with 3 presets LOW/MED/HIGH temperature settings.

Specification subject to change



# Thurmaduke®

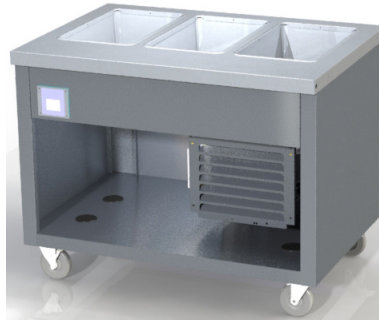
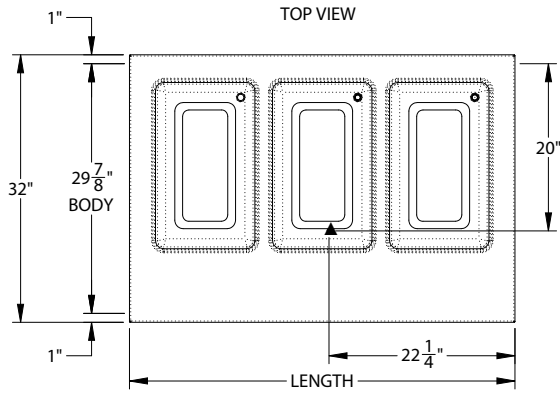

## Control Specification

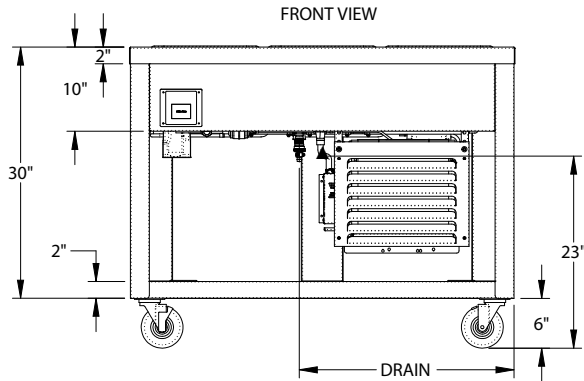
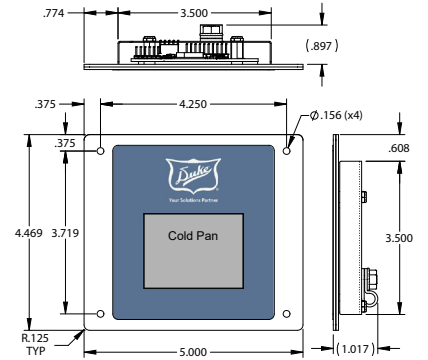

## SIDE VIEW

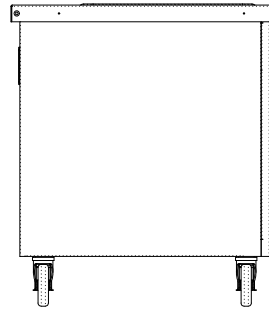

## Control Cutout

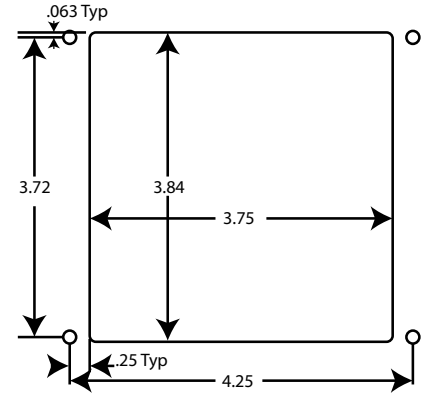

### LEGEND

▲ - ELECTRICAL CONNECTION - 6' Cord & Plug

### DIMENSIONS:

### FREIGHT CLASS: 150

Model	Length		Width		Height		Cube ft. crated	Weight	
	in	cm	in	cm	in	cm		lbs	kg
TFCP-32-N7	32	81.3	32.00	81.3	36	91.4	27.6	285	129.3
TFCP-46-N7	46	116.8	32.00	81.3	36	91.4	37.7	310	141.0
TFCP-60-N7	60	152.4	32.00	81.3	36	91.4	47.9	386	175.5
TFCP-74-N7	74	188.0	32.00	81.3	36	91.4	58.1	477	216.8
TFCP-88-N7	88	223.5	32.00	81.3	36	91.4	68.4	575	260.8

### ELECTRICAL SPECIFICATIONS: \*If optional condensate evaporator add 300 Watts, 2.6 Amps

Model	120 Volt/NEMA 5-15			Model	120 Volt/NEMA 5-15		
	Watts	Amps	NEMA		Watts	Amps	NEMA
TFCP-32-N7	432	3.7	5-15	TFCP-74-N7	576	4.9	5-15
TFCP-46-N7	576	4.9	5-15	TFCP-88-N7	576	4.9	5-15
TFCP-60-N7	576	4.9	5-15				



**Duke Manufacturing Co.**  
2305 N. Broadway  
St. Louis, MO 63102

Phone: 314-231-1130  
Toll Free: 1-800-735-3853  
Fax: 314-231-5074

www.dukemfg.com