



CDR-1550 Dough Roller



Ideal for:

- Flour Tortillas
- Pierogi
- Sheeting
- Rolled In Dough
- Pita Bread
- Naan
- Calzones
- Roti
- Sweet Doughs
- Flatbread

Highlights:

- Front operated, sheets 500-600pcs per hour up to 15" (38cm)
- Ships standard with synthetic, non-stick rollers
- Ergonomic design makes it easy and simple to operate
- Sheets dough to a uniform thickness in seconds
- All stainless steel construction offers safety, sanitation, speed, simplicity, durability, and low cost

CDR-1550 Dough Roller

CDR-1550 Synthetic Rollers
CDR-1550M Metallic Rollers

Features

- Simple handle adjustments for exact uniform dough thickness
- Spring loaded scrapers readily removable for easy cleaning
- Safety sensors for automatic shutoff
- Compact design, ideal for use in limited space
- Ergonomic design for easy operation
- Convenient front operation
- Large hopper accepts large pieces of dough
- Maintenance free drive mechanism
- Drive mechanism isolated from roller area
- Sanitary, heavy duty, all stainless steel welded construction
- Safe, simple, easy to operate, easy to clean

Industry Uses

- Pizzerias
- Restaurants
- Institutions
- Schools
- Mexican establishments
- Ethnic food production
- Cafes
- Bakeries
- Naan
- Roti
- Flatbread

Contact us

978.667.3355 | 800.772.440

Fax: 978.671.9466

Email: somerset@smrset.com

smrset.com

Somerset Industries, Inc.
137 Phoenix Ave
Lowell, MA 01852 USA



Specifications

(Specifications subject to change without notice)

Rollers: 3.5" dia. by 15" length
(8.89cm dia. by 38.10cm length)

Scrapers: Synthetic, Spring Loaded, Removable

Bearings: Sealed Ball Bearings, Permanently Lubricated

Gear Motor: Heavy Duty 1/2 HP, Maintenance Free,
Single Phase, 115v/60Hz or 220v/50Hz

Finishing: All Stainless Steel

Legs: 4" Adjustable, Stainless Steel

Shipping Weight: 172lbs (78kgs)

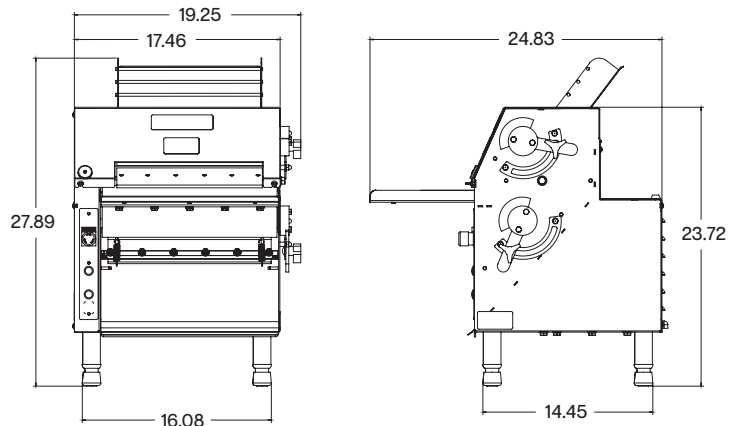

Scan the code to learn
more about the CDR-1550