



# CUTTER-EMULSIFIER KE-4V 120/50-60/1

Bowl capacity: 4.65 qt. Adjustable speed with “brushless” technology.

P/N. 1051008



DYNAMIC PREPARATION  
CUTTER-MIXERS & EMULSIFIERS

## SALES DESCRIPTION

- ✓ Compact ULTRA line. Variable speed motor block + 4.65 qt cutter bowl with lateral stirrers and toothed blades.
- ✓ Ideal for emulsions and texturizations.
- ✓ Brushless technology: maximum efficiency.

### Achieve #ThePerfectTexture in seconds, consistently and repeatably

- ✓ The cutter-emulsifier-texturizer is ideal for adapting food texture to the needs of people with dysphagia, ensuring their safety and well-being while allowing them to enjoy full flavor, preserve nutritional value, and improve food acceptance.

### Equipped with “brushless” technology: powerful and efficient motors.

- ✓ Maximum efficiency: maintain the torque throughout the speed range.
- ✓ Lightweight and compact design: they weigh less, they occupy less space.
- ✓ Improved air/water-tightness since no ventilation is required.
- ✓ They generate less noise: improved workplace environment.

### Efficiency and performance.

- ✓ Possibility of programming by time and pulse button.
- ✓ 4.4 lt-bowl equipped with lateral stirrer and high shaft for larger production capacity.
- ✓ Transparent lid equipped with hole to add ingredients in use.
- ✓ Lid complete with gasket to avoid product overflowing.
- ✓ Homogeneous and fine mixing result thanks to the lateral stirrers and inverted blade.
- ✓ The lateral stirrers avoid product overheating.
- ✓ Very uniform finish due to the movement generated the special position of the cutting edges.

- ✓ Depending on usage, optional smooth or perforated blades available.
- ✓ Built-in parametrisable programs to obtain the desired texture in seconds and in a standardized way: dense texture, fine texture, pulses (PrecisePulse function).
- ✓ Option to customize programs for recipe standardization.
- ✓ Optional vegetable slicer attachment available.

### Built to last

- ✓ Sturdy construction in food-grade best quality materials.

### Maximum comfort for the user

- ✓ Cutter bowl equipped with ergonomic handle.
- ✓ Advanced control panel that is very intuitive to use and offers all the information at a glance.
- ✓ Control panel equipped with timer to standardise processes.
- ✓ Recessed cord relief allowing flush against wall operation

### Maintenance, safety, hygiene

- ✓ Safety microswitches in the position of the bowl and the lid.
- ✓ Complete error warning system.
- ✓ Appliance certified by NSF International (regulations on hygiene, cleaning and materials suitable for contact with foods).
- ✓ 100% tested.

## INCLUDES

- ✓ Variable speed motor block.
- ✓ Cutter bowl with toothed blades.

## OPTIONAL

- Hub with smooth blades.
- Vegetable slicer attachment.
- Hub with perforated blades.

## ACCESSORIES

- Cutter bowl
- Hubs with blades
- Vegetable preparation attachment for K-41 / KE-4V



SAMMIC, S.L. · Basarte, 1  
20720 AZKOITIA (Gipuzkoa) · SPAIN

Intertek

GOLD SPONSOR



# CUTTER-EMULSIFIER KE-4V 120/50-60/1

Bowl capacity: 4.65 qt. Adjustable speed with “brushless” technology.



P/N. 1051008

## SPECIFICATIONS

Electrical supply: 120 V / 50-60 Hz / 1~ (5.3 A)  
 Plug: USA (NEMA 5-15P / 2P+G)  
 Bowl capacity: 4.65 qt  
 Max. product capacity: 5.5 lb  
 Maximum capacity (liquid): 2.5 qt  
 Bowl dimensions: Ø7.6” x 6.34”  
 Total loading: 2 Hp (14 A)  
 Speed, min-max: 300 rpm - 3000 rpm

## External dimensions (W x D x H)

✓ Width: 9.9”  
 ✓ Depth: 12.2”  
 ✓ Height: 17.1”  
 Net weight: 26.2 lb  
 Crated dimensions  
 11.2 x 15.2 x 27.4 “  
 Volume Packed: 0.08 m³  
 Gross weight: 35.5 lbs.

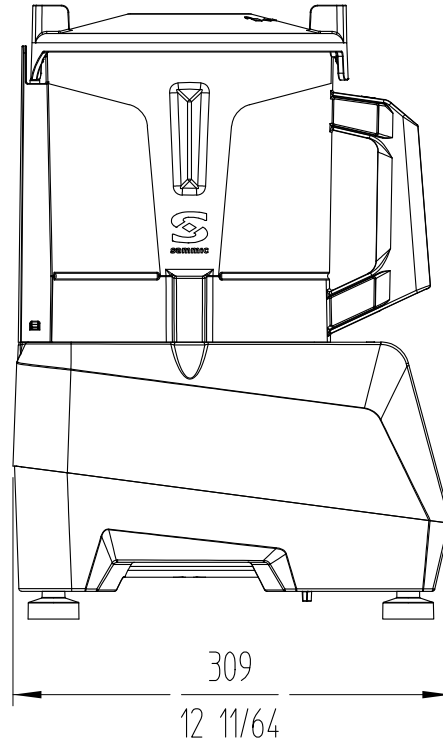
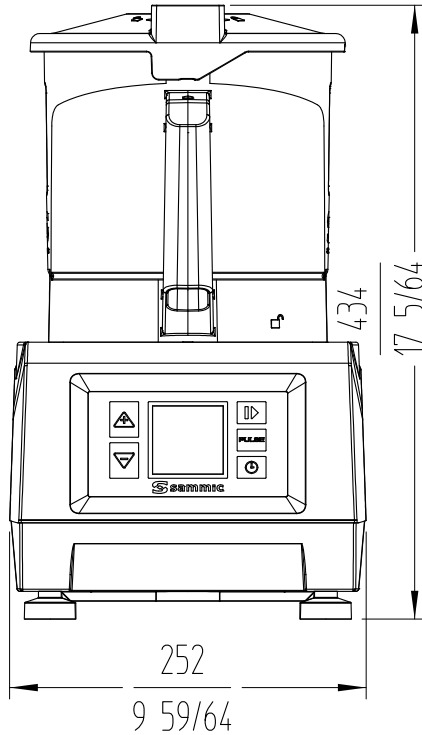

DYNAMIC PREPARATION  
CUTTER-MIXERS & EMULSIFIERS

**sammic** | sammic.us  
 Food Service Equipment Manufacturer

usa@sammic.com phone +1 (224) 307-2232  
 1225 Hartrey Avenue toll free +1 844 275 3848  
 60202-1056 Evanston, IL

Project	Date
Item	Qty
Approved	

product sheet  
updated 10/03/2026