



Project _____

Item # _____

Quantity _____

Hatco®/Suntec Flip Waffle Makers

Model: FWM-1B

Hatco®/Suntec Flip Waffle Makers produce excellent, authentic 1¼" (32 mm) thick, round Belgian waffles. Their unique heating elements and 180° swivel mechanism ensure even cooking, while a thermostatic control and a programmable timer deliver consistent, repeatable results. Adjustments to temperature and time can be made to suit any batter and the unit is memory retentive so you may only have to program it once.

Standard features

- Commercial food service quality – designed for many hours of continuous use, every day
- Heavy duty stainless steel construction with Teflon® coated aluminum plates
- Simple push-button control panel features a stand-by on/off, timer/temperature toggle, higher/lower selection, and start
- Easy to see bright red LED display shows settings and countdown when cooking
- Timer starts automatically when waffle maker is closed and resets when opened, while a beeper signals the end of a cooking cycle
- Fast initial heat up time, excellent heat retention and recovery delivers high productivity
- Models shipped with NEMA 5-15P plug and cord (attached)



FWM-1B

*Standard Round Belgian Plate
7" (178 mm)
diameter*

*Mini Round Waffle Plate available as accessory
Four 3⁵/₃₂ (80 mm)
diameter*



Accessories

- Waffle Brush - For easy cleaning
- Waffle Fork
- Mini Waffle Plate



For operation, location and safety information, please refer to the Installation and Operating Manual.



HATCO CORPORATION

P.O. Box 340500 Milwaukee, WI 53234-0500 U.S.A. | (414) 671-6350



www.hatcocorp.com

support@hatcocorp.com

[Find a Hatco Rep](#)

[Image Library](#)

[Document Library](#)

[Patents](#)

[Chat](#)



Hatco®/Suntec Flip Waffle Maker

Models: FWM-1B

FWM-1B

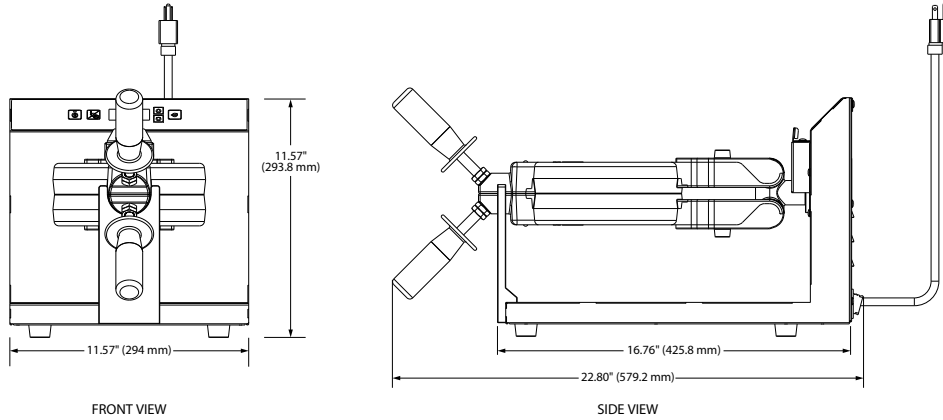

SPECIFICATIONS Flip Waffle Maker

Model	Item No.	Description	Dimensions (W x D x H)	Voltage	Watts	Amps	HZ	Plug	Approx. Ship Weight
FWM-1B	FWM1B.515	single, round	11.57" x 22.80" x 11.57" (294 x 579 x 294 mm)	120	1350	11.3	50-60	NEMA 5-15P	26.5 lbs. (12 kg)
				100	1350	13.5	50-60	PSE	
				220-240	1235-1470	5.7-6.2	50-60	BS-1363, Schuko, AU, CCC	
				220	1235	5.7	60	BS-1363	

CORD LOCATION

Bottom center of unit.

PLUG CONFIGURATION

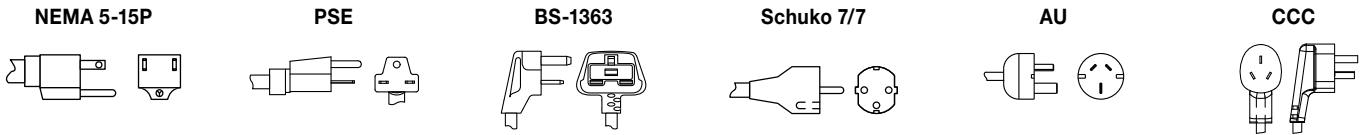

PRODUCT SPECS Waffle Makers

The Waffle Makers shall be Model ... as distributed by the Hatco Corporation, Milwaukee, WI 53234 U.S.A.

The Waffle Maker shall be rated at ... watts, ... volts, and be ... inches (millimeters) in overall width.

It shall consist of stainless steel frame and cast iron waffle plates. Waffle Makers

feature removable cast iron waffle plate for Belgian waffles. Also, an adjustable Temperature Control and a power indicator. All units are equipped with a factory attached 6' (1829 mm) power cord and plug.

Accessories shall include a waffle brush, waffle fork and mini waffle plate.

Warranty consists of 24/7 parts and service assistance (US and Canada only).

HATCO CORPORATION | P.O. Box 340500 Milwaukee, WI 53234-0500 U.S.A. | (414) 671-6350



www.hatcocorp.com | support@hatcocorp.com | [Find a Hatco Rep](#) | [Image Library](#) | [Document Library](#) | [Patents](#) | [Chat](#)