

## "GS6-SBK" EQUIPMENT STANDS

*16GA Stainless Steel Top w/Stainless Steel Base & Bracing*

### FEATURES:

- 16GA Type 300 Stainless Steel Top With #4 Polish, Satin Finish
- 1-1/2" Stallion Edge On Front. Turned Up Back And Both Sides
- Top Frame Is Reinforced By A Full Frame Fabricated Of 1-1/2" Square O.D. Tube 16GA Stainless Steel
- Stainless Steel Base
- Shipped Knocked-Down, Easy-To-Assemble (Welded Setup Available)

### SPECIFICATIONS:

- Top: Stainless Steel Tops Are TIG Welded, Exposed Welds Are Polished To Match Adjacent Surface
- Top: 16GA Stainless Steel Type 300 Stainless Steel With #4 Polish, Satin Finish
- Bracing: 1-1/4" Round O.D. 18GA Tubular Stainless Steel
- Legs: 1-5/8" Round O.D. 16GA Tubular Stainless Steel
- Gussets: Stainless Steel
- Feet: 1" Adjustable Stainless Bullet Feet



GS6-3048SBK

### CERTIFICATIONS:



## "GS6-SBK" EQUIPMENT STANDS

| LENGTH | 24" WIDE      | WT. (LBS) | 30" WIDE      | WT. (LBS) | 36" WIDE      | WT. (LBS) |
|--------|---------------|-----------|---------------|-----------|---------------|-----------|
| 15"    | GS6-2415SBK   | 20        | GS6-3015SBK   | 25        | GS6-3615SBK   | 35        |
| 18"    | GS6-2418SBK   | 25        | GS6-3018SBK   | 30        | GS6-3618SBK   | 40        |
| 24"    | GS6-2424SBK   | 40        | GS6-3024SBK   | 45        | GS6-3624SBK   | 55        |
| 30"    | GS6-2430SBK   | 55        | GS6-3030SBK   | 60        | GS6-3630SBK   | 70        |
| 36"    | GS6-2436SBK   | 65        | GS6-3036SBK   | 69        | GS6-3636SBK   | 85        |
| 48"    | GS6-2448SBK   | 80        | GS6-3048SBK   | 90        | GS6-3648SBK   | 100       |
| 60"    | GS6-2460SBK   | 95        | GS6-3060SBK   | 111       | GS6-3660SBK   | 127       |
| 72"    | GS6-2472SBK * | 111       | GS6-3072SBK * | 132       | GS6-3672SBK * | 154       |

**\*NOTE: HAS 3 SETS OF LEGS**

ALL DIMENSIONS ARE TYPICAL. TOLERANCE +/- .500". JOHN BOOS & CO. RESERVES THE RIGHT TO CHANGE SPECIFICATIONS WITHOUT NOTICE.

# DETAILED SPECIFICATIONS

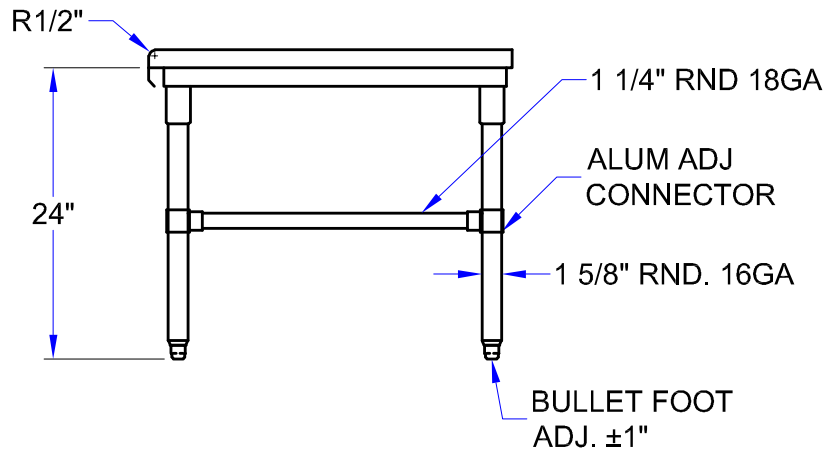
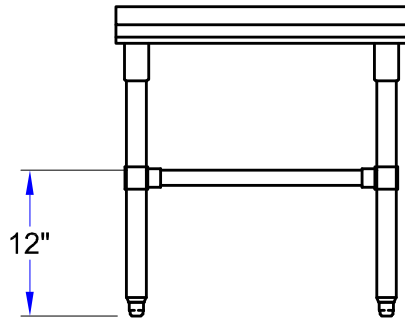
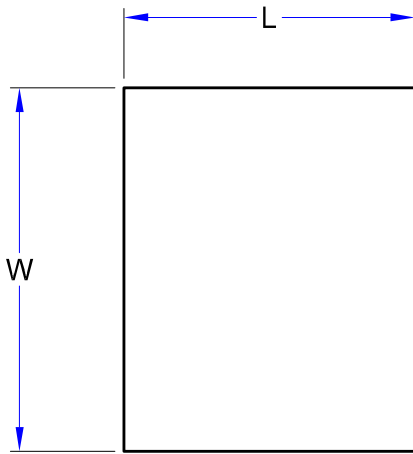

## "GS6-SBK" EQUIPMENT STANDS

| LENGTH | 24" WIDE      | WT. (LBS) | 30" WIDE      | WT. (LBS) | 36" WIDE      | WT. (LBS) |
|--------|---------------|-----------|---------------|-----------|---------------|-----------|
| 15"    | GS6-2415SBK   | 20        | GS6-3015SBK   | 25        | GS6-3615SBK   | 35        |
| 18"    | GS6-2418SBK   | 25        | GS6-3018SBK   | 30        | GS6-3618SBK   | 40        |
| 24"    | GS6-2424SBK   | 40        | GS6-3024SBK   | 45        | GS6-3624SBK   | 55        |
| 30"    | GS6-2430SBK   | 55        | GS6-3030SBK   | 60        | GS6-3630SBK   | 70        |
| 36"    | GS6-2436SBK   | 65        | GS6-3036SBK   | 69        | GS6-3636SBK   | 85        |
| 48"    | GS6-2448SBK   | 80        | GS6-3048SBK   | 90        | GS6-3648SBK   | 100       |
| 60"    | GS6-2460SBK   | 95        | GS6-3060SBK   | 111       | GS6-3660SBK   | 127       |
| 72"    | GS6-2472SBK * | 111       | GS6-3072SBK * | 132       | GS6-3672SBK * | 154       |

\*NOTE: HAS 3 SETS OF LEGS

ALL DIMENSIONS ARE TYPICAL. TOLERANCE +/- .500". JOHN BOOS & CO. RESERVES THE RIGHT TO CHANGE SPECIFICATIONS WITHOUT NOTICE.