



Project \_\_\_\_\_  
 AIA # \_\_\_\_\_ SIS # \_\_\_\_\_  
 Item # \_\_\_\_\_ Quantity \_\_\_\_\_ C.S.I. Section 114000

## A-Series

W-Width Reach-In Refrigerator Model  
 32" Deep, Self-Contained



### STANDARD PRODUCT FEATURES

- Traulsen's Smart Control with LED Display
- StayClear™ Condenser Coil
- Stainless Steel Exterior/Anodized Aluminum Interior
- Balanced, Self-Contained Refrigeration System Using R-450A
- Rear Biased Return Air Duct
- Full or Half-Height Stainless Steel Doors with Locks
- Anti-Condensate Door Perimeter Heater
- Self-Closing Doors with Stay Open Feature at 120 Degrees
- Standard Door Hinging: 332W = Left/Right/Right (other hings available)
- Automatically Activated LED Lights
- Stainless Steel Breaker Caps
- Three Adjustable, Coated Wire Shelves Per Section, Supported on Shelf Pins (factory installed)
- Automatic Non-Electric Condensate Evaporator
- Magnetic Snap-In EZ-Clean Door Gaskets
- Gasket-Protecting Raised Door Liners
- Thermostatic Expansion Valve Metering Device
- Stainless Steel One-Piece Louver Assembly
- 9' Cord & Plug Attached
- Set of (4) 6" High Adjustable Stainless Steel Legs



Models listed to the applicable UL, CSA and NSF standards by an approved NRTL. Consult the factory or unit data plate for additional information.

### AVAILABLE CONFIGURATIONS

#### A-Series Models

AHT332WUT-FHS  
 AHT332WUT-HHS

#### Door(s)

Full Height Solid  
 Half Height Solid

**\*Remote application available,  
 see form TR35837 for details.**

- **GUARANTEED FOR LIFE CAM-LIFT HINGES**
- **GUARANTEED FOR LIFE HORIZONTAL WORK FLOW DOOR HANDLES (SOLID DOORS ONLY)**

### ACCESSORIES & OPTIONS

- R-290 Refrigerant Option
- SmartConnect™ Monitoring App with Wi-Fi Connectivity
- Accommodates EZ-Clean™ Tray Racks
- Option to Relocate Electrical Box
- Stainless Steel Finished Back with Rear Louvers
- #1 Type Trayslides to Accommodate either (1) 18" x 26" or (2) 14" x 18" Pans
- #4 Type Trayslides to Accommodate 18 to 19 Levels for 18" x 26" Pans
- Universal Type Trayslides to Accommodate Either (1) 18" x 26", (2) 14" x 18", or (2) 12" x 20" Pans
- Additional Coated Wire or Optional Stainless Steel Shelves
- Stainless Steel Banking Strip
- EZ-Open Foot Pedals (full-height doors only)
- Positive Action Latch (consult factory)
- Locking Hasps (padlocks supplied by others)
- Optional 208-230/115/60/1 or 208-230/60/1 Voltages
- Export 220-240/50/1 Voltage
- Kool Klad Exterior Laminate Decor (consult factory)
- Set of (4) 4 1/8" or 6" High Casters in Lieu of Legs
- 6" Stainless Steel Flanged Legs
- Other Support Options: 4 1/2" High Base or 6" High Kickplate (for use with standard legs)
- Clear Glass Door(s) in Place of One or More Solid Door(s)
- Heat Shield
- Remote Glycol Application (consult factory)



ENERGY STAR® Listed Commercial Refrigerator  
 For full listing visit [energystar.gov](http://energystar.gov)

Approved by \_\_\_\_\_ Date \_\_\_\_\_ Approved by \_\_\_\_\_ Date \_\_\_\_\_



# A-Series

W-Width Reach-In Refrigerator Model  
32" Deep, Self-Contained

## MODEL

AHT332WUT-HHS

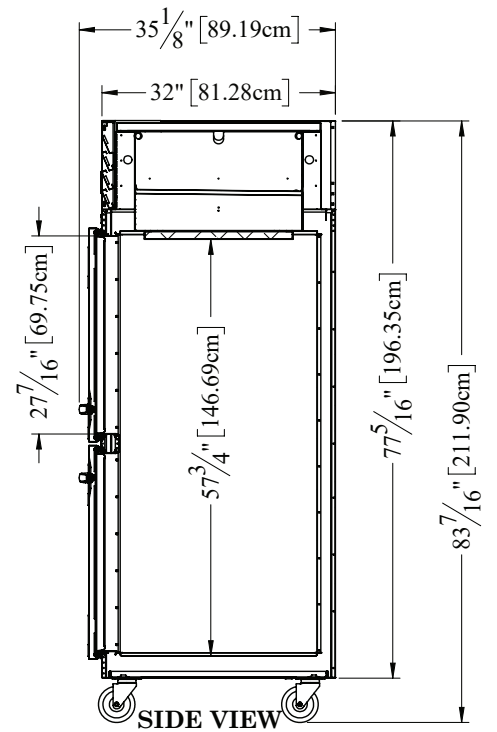
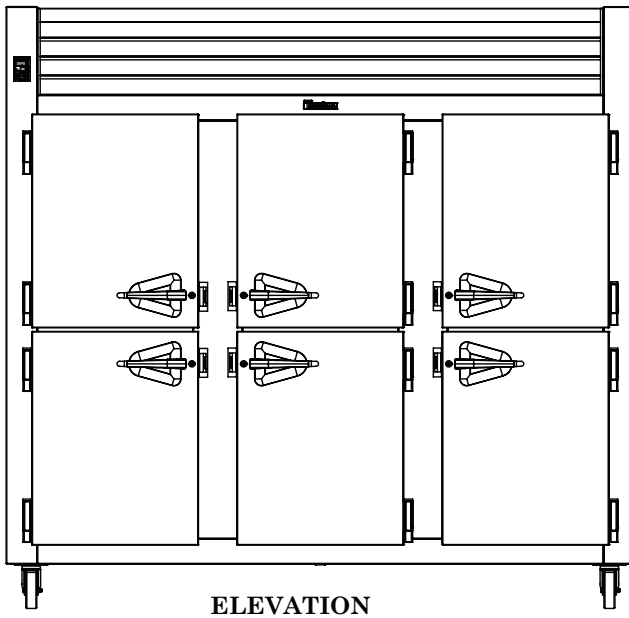
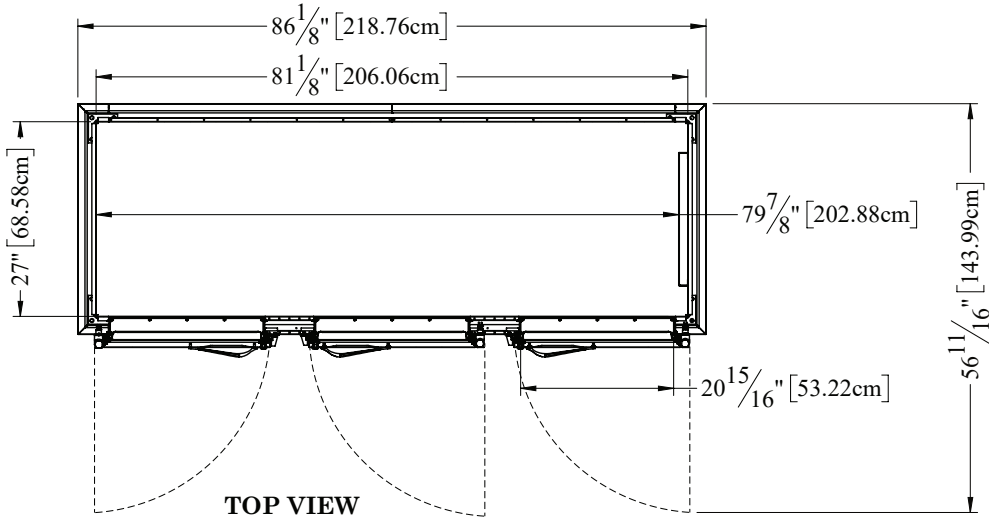

> CAD and/or Revit Files Available

<https://traulsen.klccad.com/>



# A-Series

W-Width Reach-In Refrigerator Model  
32" Deep, Self-Contained

## MODEL

AHT332WUT-FHS

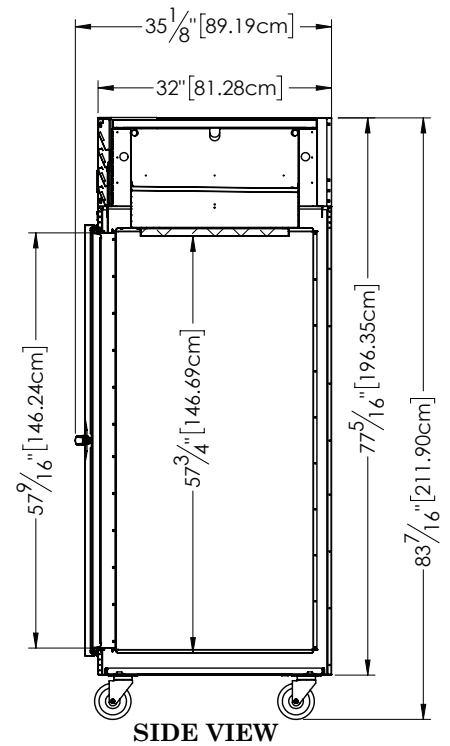
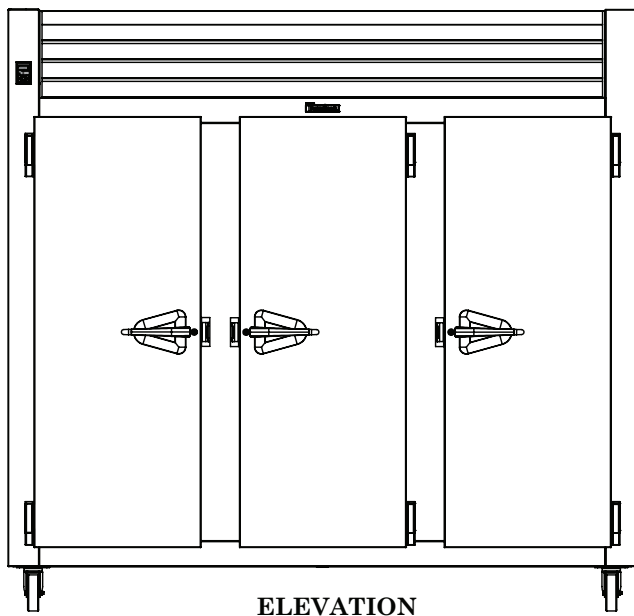
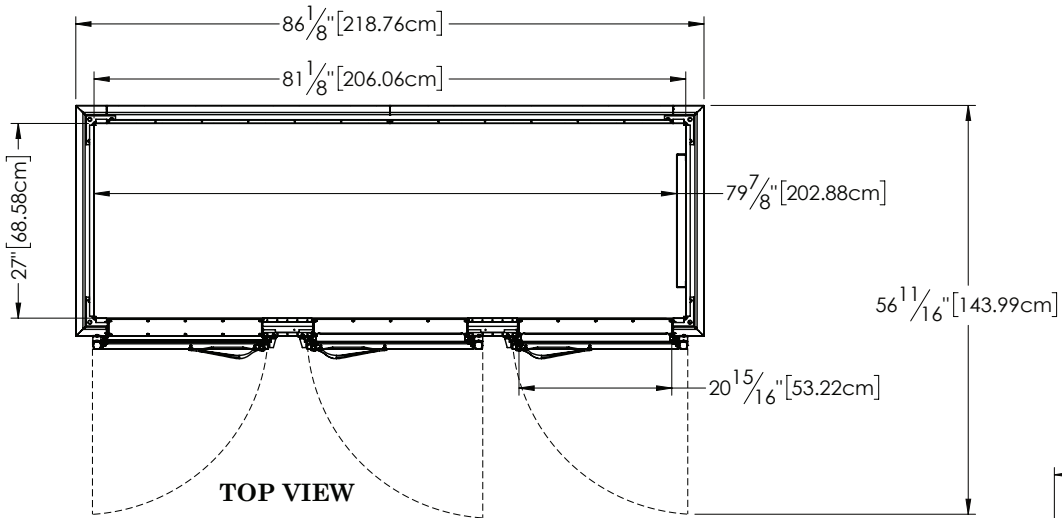

> CAD and/or Revit Files Available

<https://traulsen.kclcad.com/>



### MODEL

AHT332WUT-HHS  
AHT332WUT-FHS

### EQUIPMENT SPECIFICATIONS

MODELS	AHT332WUT
<b>DIMENSIONAL DATA</b>	
Net capacity cu. ft.	77.45 [2193.1 cu l]
Length - overall in.	86 1/8" [218.8 cm]
Depth - overall in.	35 1/8" [89.2 cm]
Depth - over body in.	32" [81.3 cm]
Depth - door open 90° in.	56 11/16" [144 cm]
Clear door width in.	20 15/16" [53.2 cm]
Clear half-door height in.	27 7/16" [69.8 cm]
Clear full-door height in.	57 9/16" [146.3 cm]
Height - overall on 6" legs <sup>2</sup>	83 7/16" [211.9 cm]
No. Standard Shelves	9
Shelf area sq. ft. <sup>3</sup>	42.04 [3.9 sq. m]
<b>ELECTRICAL DATA</b>	
Voltage   Plug	115/60/1   NEMA 5-15P
Full Load Amperes   MDEC <sup>4</sup>	10.7   4.97 kWh/Day
<b>REFRIGERATION DATA</b>	
Refrigerant	R-450A
Refrigerant Charge Amount oz.	30 [850.49 g]
BTU/HR   H.P. <sup>1</sup>	4900   3/4 HP
<b>SHIPPING DATA</b>	
Length - Crated in.	91" [231.14 cm]
Width - Crated in.	42" [106.7 cm]
Height - Crated in.	85" [215.9 cm]
Volume - Crated cu. ft.	188 [5323.6 cu l]
Weight - Crated lbs.	786 [356.5 kg]

#### CONSTRUCTION, HARDWARE, INSULATION

Cabinet exterior front, one piece sides, louver assembly & doors are constructed of heavy gauge stainless steel. Cabinet interior & door liners are also constructed of heavy gauge anodized aluminum. The exterior cabinet top, back & bottom are constructed of heavy gauge galvanized steel. A set of four (4) adjustable 6" high stainless steel legs are included.

Doors are equipped with a gasket-protecting metal door pan, removable plug cylinder locks & guaranteed for life cam-lift, gravity action, self-closing metal, glide hinges with stay open feature at 120 degrees. Hinges include a concealed switch to automatically activate the interior LED lighting. Guaranteed for life, work flow door handles are mounted horizontally over recess in doors which limits protrusion from door faces into aiseways. Doors have seamless, polished metal corners.

Gasket profile & EZ-Clean material simplify cleaning & increase overall gasket life. Anti-condensate heaters are located behind the door opening. Both the cabinet & door is insulated with an average of 2" thick high density, non-CFC, foamed in place polyurethane.

#### SELF-CONTAINED REFRIGERATION SYSTEM

A top mounted, self-contained, balanced refrigeration system using environmentally friendly, non-flammable R-450A refrigerant is conveniently located behind the one piece louver assembly. It features a finless StayClear™ condenser, thermostatic expansion valve, air-cooled hermetic compressor, large, high humidity evaporator coil located outside the food zone & top mounted non-electric condensate evaporator. Rear biased return air duct protects against introduction of warm kitchen air, promoting even temperature maintenance & efficient operation. A 9' cord & plug is provided. Standard operating temperature is 34-38°F.

#### CONTROL

Traulsen's Smart Control features advanced control algorithms & sophisticated diagnostic capabilities to optimize performance. Utilizing Smart Sensors, it adapts the operation of the refrigeration system to a variety of environments & usage patterns. The Smart Control also offers a complete set of visual alarms designed to alert the user to critical events such as power outages or a prolonged door opening. In the event of an alarm, a dedicated Alarm LED will illuminate, informing the user of the critical event and duration.

#### INTERIOR

Standard interior arrangements include three (3) coated wire shelves per section, mounted on shelf pins. Shelves are full-width & do not have any large gaps between them requiring the use of "bridge" or "junior" shelves. Recommended load limit per shelf should not exceed 225 lbs. Interior arrangements are installed at the factory & EZ-Change interior slides (only) are field installed.

#### WARRANTY

Both a six year parts and labor warranty and a seven year compressor warranty (self-contained models only) are provided standard.

**NOTES:** Figures in parentheses reflect metric equivalents.

1. Based on a 90°F ambient and 20°F evaporator.
2. 12" Top clearance preferred for optimum performance & service access.
3. Area of standard shelf compliment only, does not include storage area of additional shelves or available on cabinet bottom.
4. MDEC = MAXimum Daily Energy Consumption

When ordering please specify: Voltage, Hinging, and Options.

Equipped with one NEMA 5-15P Plug



CONTINUED PRODUCT DEVELOPMENT MAY NECESSITATE SPECIFICATION CHANGES WITHOUT NOTICE.