



SERVING THE FOOD INDUSTRY SINCE 1951

## 40" Convection Ovens Full Size

ITEM: 47750 48060  
 MODEL: CE-CN-0001-NG CE-CN-0002-NG

**Perfect for virtually all cooking and baking applications, this represents a pinnacle in culinary equipment.**



SINGLE DECK  
47750



DOUBLE DECK  
48060

Whether managing a bustling restaurant or catering a special occasion, this convection oven guarantees consistent and impeccable results. Elevate your culinary endeavors by incorporating this premium appliance into your kitchen.

**FEATURES:**

• **Timer control**

ensures that your dishes are cooked to perfection, allowing you to focus on adding that extra dash of flavor or perfecting the presentation.

• **Thermostat control**

ensures precise temperature regulation, while the fan control helps to evenly distribute heat throughout the oven for consistent cooking results. With an advanced system, this oven efficiently circulates hot air, ensuring uniform cooking results on every occasion.

• **Interior light control**

not only showcases your delicious creations but also helps you keep an eye on their progress without losing any heat by opening the oven door.

• **Heavy-duty casters**

take the functionality of these ovens to the next level by offering easy mobility. This feature not only ensures convenience for chefs and kitchen staff but also enhances safety by keeping the oven elevated and clean from any wet or grease on the floor.

*\*Gas conversion kit included*

Telephone: 1-800-465-0234

Fax: (905) 607-0234

Email: sales@omcan.com

Website: www.omcan.com



Authorized Dealer



**1 YEAR WARRANTY**  
PARTS AND LABOUR



TECHNICAL SPECIFICATION		
Features	Single Deck Oven	Double Deck Ovens
Item	47750	48060
Model	CE-CN-0001-NG	CE-CN-0002-NG
Gas Type	Natural Gas	Natural Gas
BTU (per Hour)	60,000	60,000 (x2)
Number of Ovens	1	2
Number of Doors	2 Swing Doors	2 Swing Doors (x2)
Number of Shelves	3	3 (x2)
Shelf Size	28.13" x 25.38" (714 x 643 mm)	28.13" x 25.38" (714 x 643 mm)
Casters	Yes	Yes
Electrical	110-120V / 60Hz / 1Ph	110-120V / 60Hz / 1Ph
Temperature Range	75 - 295°C (67 - 563°F)	75 - 295°C (67 - 563°F)
Oven Dimensions (WDH)	29" x 26.4" x 20" (737 x 670 x 755 mm)	29" x 26.4" x 20" (737 x 670 x 755 mm) (x2)
Net Weight	412 lb. (187 kg.)	805 lb. (365 kg.)
Net Dimensions (WDH)	39" x 40" x 56" (991 x 1005 x 1422 mm)	39" x 40" x 71" (991 x 1005 x 1795mm)
Gross Weight	489 lb. (222 kg.)	948 lb. (430 kg.)
Gross Dimensions (WDH)	44" x 42" x 35" (1110 x 1060 x 890mm)	44" x 42" x 77" (1110 x 1060 x 1950mm)

## TECHNICAL DRAWING

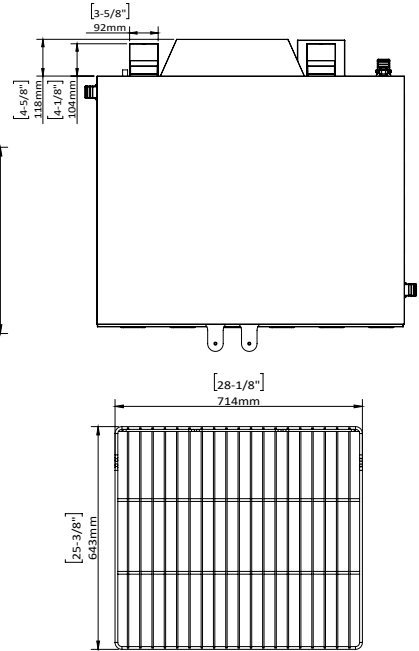
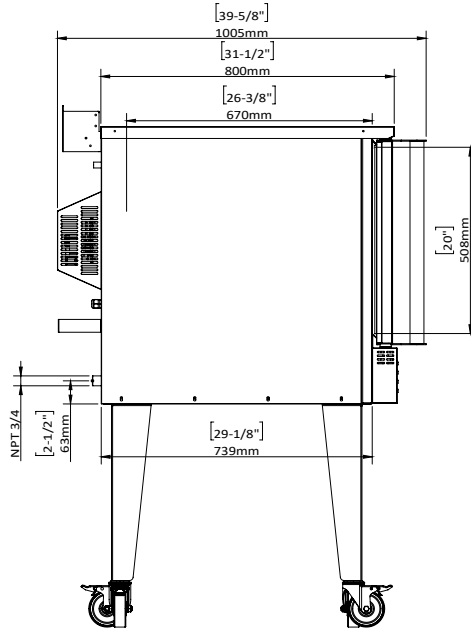
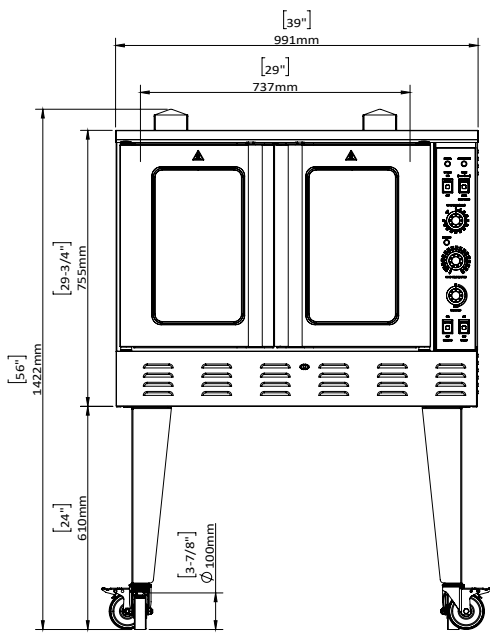

**SINGLE DECK**  
47750

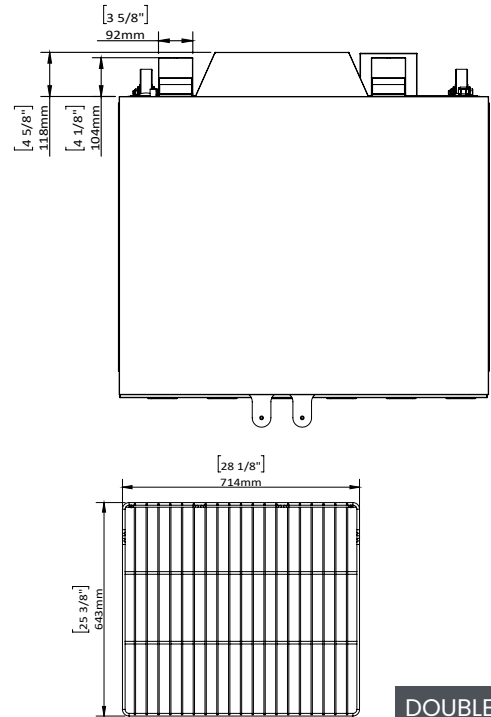
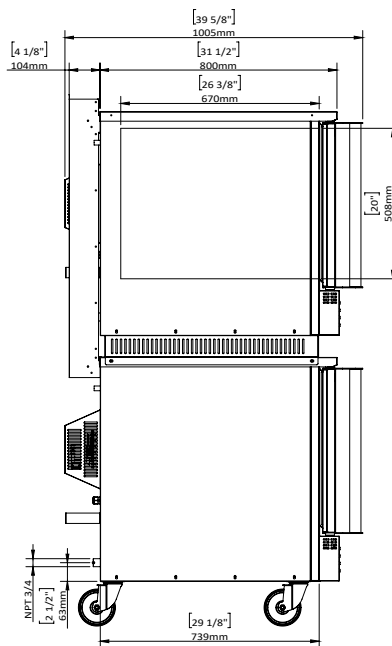
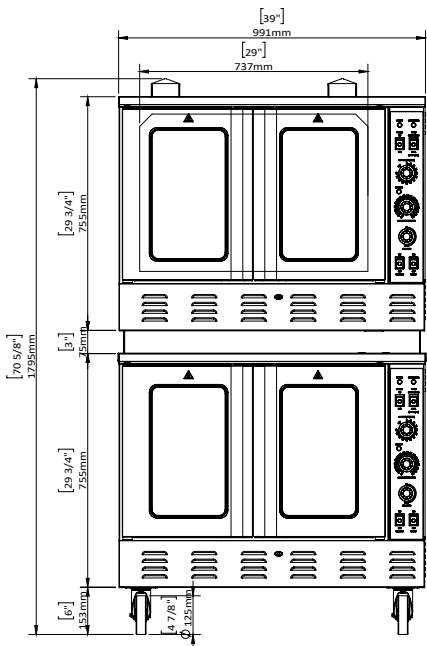

**DOUBLE DECK**  
48060