

SCS-150 Cheese Shredder

Variable Speed



Highlights:

- 3-speed variable torque for shredding soft to hand cheeses
- Shred 25+ pounds of cheese per minute
- Machine accepts 8 pound blocks of cheese
- All stainless steel construction

- UL & NSF approved
- No adjustments needed
- Maintenance free
- COMES STANDARD with 3/16" standard blade and cheese box shelf

Optional Blades Available:

- 3/32" • 5/16"
- 5/32" • 1/2"
- 1/4" • KD-GD

SCS-150 Cheese Shredder

Variable Speed

Features

- Shredder stand with casters that has 360 degree mobility with cheese box shelf
- Safety sensors for automatic shutoff
- Variable speed (low, medium, high torque) for shredding soft to hard cheeses with one unit
- Safe, simple, easy to operate and clean

Industry Uses

- Pizzerias
- Restaurants
- Mexican establishments
- Institutions
- Other ethnic food production



Specifications

(Specifications subject to change without notice)

Bearings: Sealed Ball Bearings Permanently Lubricated

Gear Motor: Heavy Duty 2HP, Maintenance Free, Single Phase, 220V – 50Hz/60Hz

Finishing: All Stainless Steel

Shipping Weight: 225 lbs. (103 kgs)

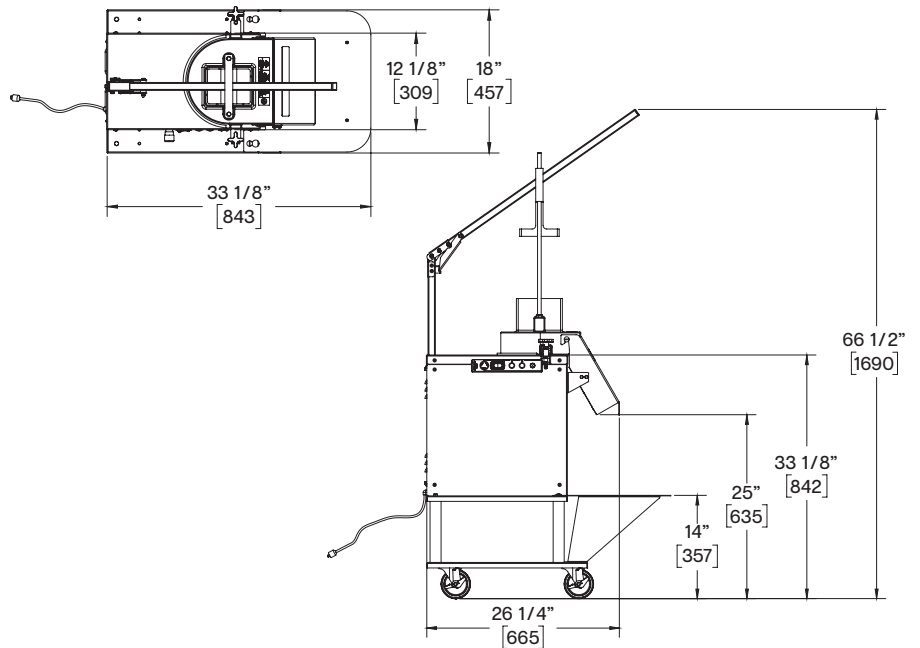

Contact us

978.667.3355 | 800.772.440

Fax: 978.671.9466

Email: somerset@smrset.com

smrset.com

Somerset Industries, Inc.
137 Phoenix Ave
Lowell, MA 01852 USA



Scan the code to learn more about the SCS-150

