

"UBDB-21-IC" UNDERBAR CORNER DRAINBOARD

21" Width

FEATURES:

- 18GA Stainless Steel Construction
- Type 300 Stainless Steel With #4 Polish, Satin Finish
- Standard Pre-Drilled Holes On Sides For Attaching Adjacent Units Together
- Creased Deck For Improved Drainage
- Removable Perforated Drainboard Insert For Increased Air Circulation.
- Stainless Steel Front To Back Bracing

SPECIFICATIONS:

- Top: 18GA Type 300 Stainless Steel
- Front Apron: 18GA Type 300 Stainless Steel
- Backsplash: 18GA Type 300 Stainless Steel
- Sides: 18GA Type 300 Stainless Steel
- Bolt On 1-5/8" Stainless Steel Legs For Fast Installation
- 1-1/4" Front To Back Bracing
- 1" Adjustable Stainless Steel Bullet Feet
- Z-Clip To Mount To Wall
- Bolt To Adjacent Underbar Piece
- Mounting Options Allow For Flexible Installation
- Options To Remove Back Or Front And Back Legs For A Clean Installation
- 1-3/8" Drain Plug
- 1" MPT 1-1/2" Long Drain Connection

CERTIFICATIONS:



UBDB-2121-90-IC

ACCESSORIES

MODEL	DESCRIPTION
UBSS-21-L	Left Hand Side Splash
UBSS-21-R	Right Hand Side Splash

"UBDB-21-IC" UNDERBAR CORNER DRAINBOARD

MODEL	SIZE (LXWXH)	WEIGHT (LBS)
UBDB-2121-90-IC	21"x21"x32-1/2"	46

ALL DIMENSIONS ARE TYPICAL. TOLERANCE +/- .500". JOHN BOOS & CO. RESERVES THE RIGHT TO CHANGE SPECIFICATIONS WITHOUT NOTICE.

DETAILED SPECIFICATIONS

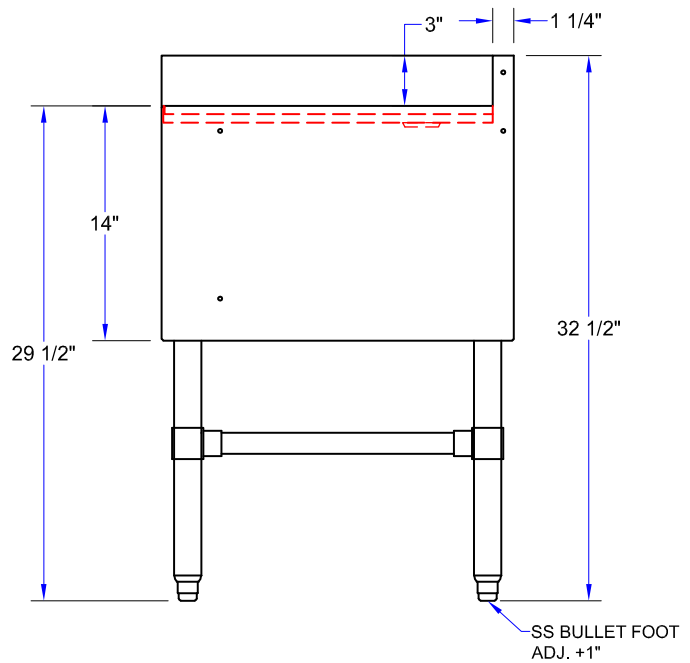
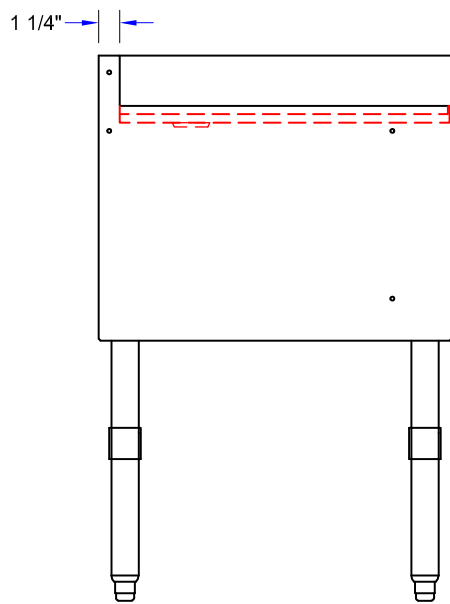
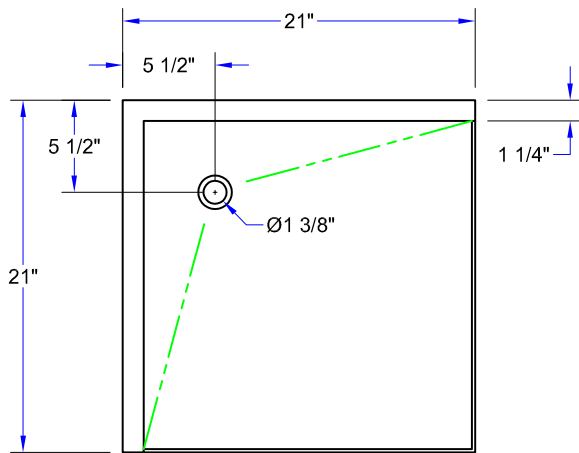

"UBDB-21-IC" UNDERBAR CORNER DRAINBOARD

MODEL	SIZE (LXWXH)	WEIGHT (LBS)
UBDB-2121-90-IC	21"x21"x32-1/2"	46

ALL DIMENSIONS ARE TYPICAL. TOLERANCE +/- .500". JOHN BOOS & CO. RESERVES THE RIGHT TO CHANGE SPECIFICATIONS WITHOUT NOTICE.