

50Hz

iT0620 Ice Cube Machine

Indigo® NXT™ iT0620 Ice Cube Machine

Models

- IRT0620A
 IDT0620A
 IYT0620A
 IDT0620W
 IYT0620W
 IRT0620W



Indigo NXT Series iT0620 Ice Machine on D420 Bin

*Ice machine and bin sold separately

Designed for operators who know that ice is critical to their business, the Indigo NXT Series ice machine's preventative diagnostics continually monitor itself for reliable ice production. Improvements in cleanability and programmability make your ice machine easy to own and less expensive to operate.

- **New levels of Performance** – Showcasing an average of 31% lower energy consumption, 16% reduction in potable water usage and a 32% reduction in condenser water usage. This translates into lower cost of ownership over the life of your machine.
- **easyTouch® Display** - New icon based touch screen takes the guess work out of owning and operating an ice machine.
- **Multiple Language Capability** - The easyTouch display is available in multiple languages selected in the initial start-up installation Wizard.
- **Programmable Ice Production** – Now its super easy to program your ice machine to be off at certain times of the day to save money with fluctuating electrical rates. Also programmable by daily ice production volume and night time programming.
- **Easy to Clean Foodzone** – Hinge front door swing out for easy access. Removable water-trough, distribution tube, curtain, water probe and water pump for fast and efficient cleaning. Selected components are made with AlphaSan® antimicrobial.
- **Intelligent Diagnostics** – Provides 24 hour preventative maintenance and diagnostic feedback for trouble free operation.
- **Acoustical Ice Sensing Probe** – Unique patented technology allows for reliable operation in challenging water conditions and environments
- Available **Lumince® II Virus and Bacteria Inhibitor** – Controls viruses, bacteria, mold and yeast within the food zone to keep the machine clean longer. A new sanitation icon lets you know the operational status.
- **Active Sense** - insures consistent ice harvest in all environmental conditions. This software solution works in conjunction with the acoustical ice sensing probe improving reliability and performance.



Ice Machine Electric

230/50/1

Minimum circuit ampacity:

Air-cooled: 5.6
Water-cooled: 5.4

Maximum fuse size:

Air-cooled: 15A
Water-cooled: 15A

Specifications

BTU Per Hour:
5,400 (average),
and 6,300 (peak)

Refrigerant:

R410A CFS - Free
Lowers global warming
by 48%

Operating Limits:

- Ambient Temperature Range:
40 to 110 F (4.4 to 43.3 C)
Water Temperature Range:
40 to 90 F (4.4 to 32.2 C)
- Potable Water Pressure:
Min. 20 psi (137.9 kPa)
Max. 80 psi (551.1 kPa)
- Condenser Water Pressure:
Min. 20 psi (137.9 kPa)
Max. 276 psi (1902.95 kPa)

Ice Shape



Half Dice
3/8" x 1 1/8" x 7/8"
(.95 x 2.86 x 2.22 cm)
Cube weight 5.7 g



Dice
7/8" x 7/8" x 7/8"
(2.22 x 2.22 x 2.22 cm)
Cube weight 8.5 g



Regular
1 1/8" x 1 1/8" x 7/8"
(2.86 x 2.86 x 2.22 cm)
Cube weight 14.2 g





iT0620 on D420 Storage Bin

- (A) Electrical Entrance (2) Options
- (B) 3/8" (0.95 cm) F.P.T. Water Condenser Inlet (water-cooled units)
- (C) 1/2" (1.27 cm) F.P.T. Water Condenser Outlet (water-cooled units)
- (D) 1/2" (1.27 cm) Auxillary Base Drain Socket
- (E) 3/8" (0.95 cm) F.P.T. Ice Making Water Inlet
- (F) 1/2" (1.27 cm) F.P.T. Ice Making Water Drain
- (G) 3/4" (1.91 cm) Bin Drain

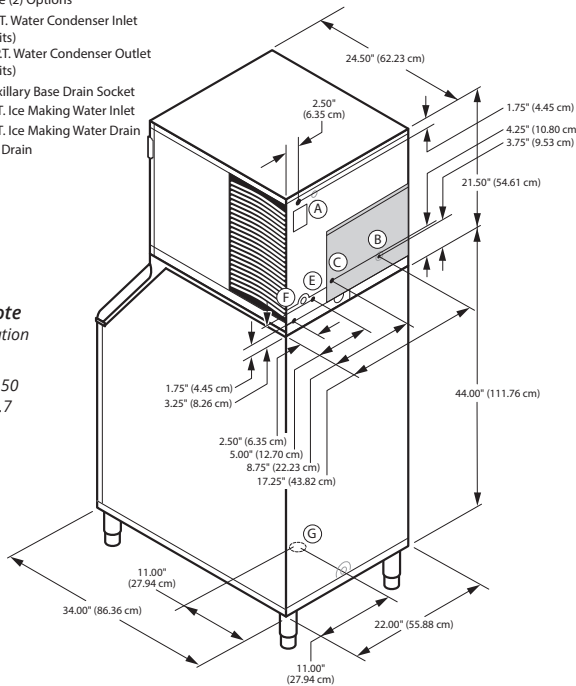

Installation Note
Minimum installation clearance:
Top/side: 12" (30.50 cm)
Back is 5" (12.7 cm)

Space-Saving Design



	iT0620 D-400	iT0620 D-420
Height	59.50" 151.13 cm	71.50" 181.61 cm
Width	30.00" 76.20 cm	22.00" 55.88 cm
Depth	34.00" 86.30 cm	34.00" 86.30 cm
Bin	365 lbs.	383 lbs.
Storage	166 kgs.	174 kgs.

Height includes adjustable bin legs 6.00" to 8.00", (15.24 to 20.32 cm) set at 6.00" (15.24 cm).
Bin capacity is based on 90% of the volume x 33 lbs/ft³ average density of ice.

K00443 bin adapter required for D400 bin. Sold separately

Specifications

Order separately: Ice storage bin for all units. This product is hermetically sealed and contains fluorinated greenhouse gas R410A

	Model	Ice Shape	Ice Production 24 Hours		Power Usage kWh 45.4 kg / 100 lbs @ 32°Air / 21°C Water 90°Air / 70°F Water	Potable Water Usage/100 lbs. 45.4 kgs. of Ice
			21°Air / 10°C Water 70°Air / 50°F Water	32°Air / 21°C Water 90°Air / 70°F Water		
AIR COOLED	IRT0620A	regular	505 lbs.	390 lbs.	1 Ph	19.9 Gal.
			229 kgs	177 kgs		
	IDT0620A	dice	535 lbs.	430 lbs.	5.18	19.9 Gal.
WATER COOLED	IYT0620A	half-dice	243 kgs	195 kgs	4.97	75.3 L
			535 lbs.	430 lbs.		
	IDT0620W	dice	510 lbs.	430 lbs.	4.13	19.9 Gal.
			231 kgs	195 kgs		
	IYT0620W	half-dice	495 lbs.	460 lbs.	4.04	19.9 Gal.
			225 kgs.	290 kgs		
IRT0620W	regular	485 lbs.	400 lbs.	4.20	19 Gal.	
		220 kgs	181 kgs			

* Water-cooled Condenser Water Usage / 100 lbs. /45.4 kgs. Of Ice: 140 gal/ 530 L.

Accessories

LuminIce® II Virus and Bacteria Inhibitor
controls viruses and bacteria inside the ice machine.



External Scoop holder
protect the ice scoop with the NSF approved versatile scoop holder.



Arctic Pure® Plus Water Filters
reduce sediments and chlorine contaminants down to .5 microns. Use with a Pre-filter is recommended.



Manitowoc Ice reserves the right to make changes to the design or specifications without prior notice.

Welbilt Deutschland GmbH
Auf der Weih 11
D - 35745 Herborn, Germany
Tel.: +49 27 72 58 050
welbilt.com.de

Welbilt Iberia, S.A.U
Textil, 6 - Pol.Ind. La Ferreria - 08110
Montcada i Reixac
Barcelona, Spain
Tel.: +34 902 20 10 69
welbilt.com.es

Welbilt UK
Ashbourne House The Guildway,
Old Portsmouth Rd Guildford GU3
1LR United Kingdom
Tel.: +44 1483 464900
www.welbilt.uk