



# VACUUM PACKING MACHINE SE-416 120/50-60/1

Tabletop model. 670 cf/h. 17"



P/N. 1140637



FOOD PRESERVATION AND SOUS-VIDE  
COMMERCIAL VACUUM PACKING MACHINES

## SALES DESCRIPTION

17" sealing bar.  
670 cf/h Busch vacuum pump.  
Vacuum controlled by sensor.

- ✓ Powered by Busch.
- ✓ Vacuum controlled by sensor.
- ✓ Vacuum PLUS.
- ✓ Digital keyboard.
- ✓ Control panel equipped with display indicating the exact vacuum percentage.
- ✓ "Pause" button to marinate food.
- ✓ Safe liquid packing thanks to sensor control.
- ✓ Double seal.
- ✓ Cordless sealing bar.
- ✓ Bag-sealing programme.
- ✓ Pulse-controlled decompression.
- ✓ Vac-Norm ready with Automatic decompression.
- ✓ Stainless steel body and chamber. Deep-drawn chamber.
- ✓ Damped transparent lid.
- ✓ Dry-oil programme for drying the pump.
- ✓ Working hours counter for oil changes.
- ✓ Safety system with protection against vacuum failure.

## INCLUDES

- ✓ Sensor controls
- ✓ Up to 10 seconds of extra vacuum pull
- ✓ Soft air function
- ✓ Dry oil cycle
- ✓ BUSCH pump
- ✓ NSF approved
- ✓ Clear methacrylate lid
- ✓ Filling plate

## OPTIONAL

- Vacuum packing bags
- External vacuum kit for Vac-Norm, containers and accessories
- Bag cutting kit
- Support for liquid packaging
- Additional filling plates

## ACCESSORIES

- Bag cutting kits
- Filling plates
- Liquid insert plates
- Vac-norm external vacuum kit
- Vac-norm containers
- Smooth bags for vacuum packing
- Trolley for vacuum packing machines
- Vacuum packing machines maintenance kits

## SPECIFICATIONS

Pump capacity: 670 cf/h  
Bar length: 17"  
Vacuum pressure (maximum): 2 mbar  
Electrical supply: 120 V / 60 Hz / 1~ (8 A)  
Plug: USA (NEMA 5-15P / 2P+G)

### Internal dimensions

- ✓ Width: 17"
- ✓ Depth: 16"
- ✓ Height: 7"

### External dimensions (W x D x H)

- ✓ Width: 19"
- ✓ Depth: 20.8"
- ✓ Height: 20.8"
- Net weight: 112.8 lb
- Background noise: 32 dB(A)
- Crated dimensions  
23.6 x 23.6 x 24.0 "
- Gross weight: 130.5 lbs.



SAMMIC, S.L. · Basarte, 1  
20720 AZKOITIA (Gipuzkoa) · SPAIN

Intertek

product sheet  
updated 13/03/2026



# VACUUM PACKING MACHINE SE-416 120/50-60/1

Tabletop model. 670 cf/h. 17"



P/N. 1140637

FOOD PRESERVATION AND SOUS-VIDE  
COMMERCIAL VACUUM PACKING MACHINES

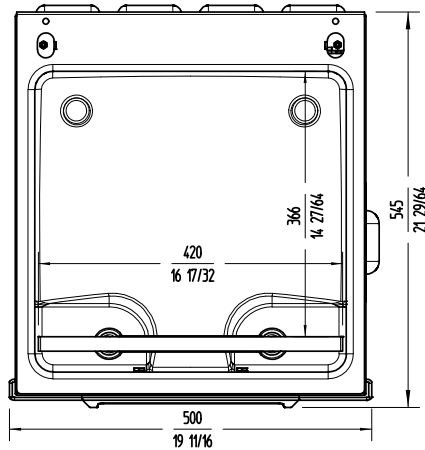
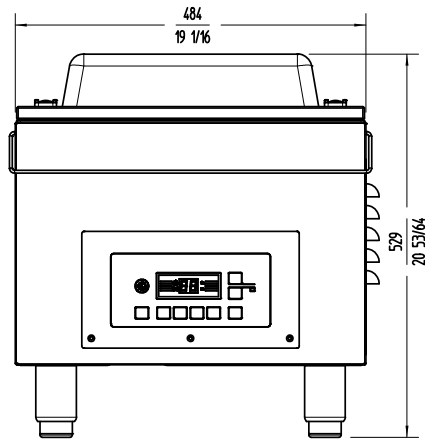
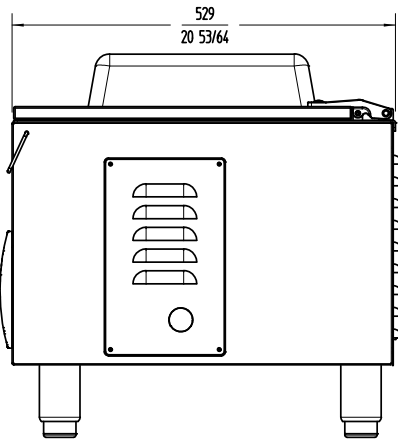

**sammic** | sammic.us  
**Food Service Equipment Manufacturer**

usa@sammic.com phone +1 (224) 307-2232  
 1225 Hartrey Avenue toll free +1 844 275 3848  
 60202-1056 Evanston, IL



Project	Date
Item	Qty
Approved	

product sheet  
updated 13/03/2026