



Item # _____

We put space to work.

Job _____

SmartLever™ Productivity System

Metro's SmartLever Productivity System is the ultimate storage and productivity solution providing you with:

More Storage Capacity: SmartLever's cantilevered design provides unobstructed access to the shelves which can mean 30-50% more storage capacity vs four post shelving in the same foot print*. Cantilevered shelving also means access to product is unhindered with posts being in the way. Product is easy-to-see and easy-to-access. Shelves are easy-to-load and easy-to-pull from.

Increased Productivity: SmartLever allows you to configure a workstation for maximum productivity by providing a variable height work surface with a variety of overhead and under work surface storage options AND a versatile SmartWall grid and accessory system allowing you to optimize the work station for specific tasks.

Unlimited Flexibility: Unlike custom fabrication, SmartLever "future proofs" your facility with a flexible system that can be reconfigured and upgraded as your operational needs change. Change is constant and SmartLever adapts with you.

A Complete System Solution: Shelving, workstations, and overhead storage all can be configured and integrated together as part of SmartLever's unique system approach to productivity.

Strength and Confidence:

- Each SmartLever section is capable of supporting a combined load of 2,800 lbs. (1270kg) (including the bottom level)
- Each SmartLever cantilevered level (shelf or work surface) is capable of supporting 600 lbs. (272kg) evenly distributed
- Dunnage shelves place on the bottom level are capable of supporting 1,000 lbs. (454kg) evenly distributed
- SmartLever components have a 10 year limited warranty against rust formation
- SmartLever arms include our patent pending ArmKeeper arm location clip

* Based on items being stored and size of shelving units.



SmartLever Shelving



SmartLever Workstation



SmartLever Shelving Workstation Integration



SmartLever Continuous Shelving



SmartLever Equipment Station



InterMetro Industries Corporation
North Washington Street, Wilkes-Barre, PA 18705
Product Information. U.S. and Canada: 1.800.992.1776
Outside U.S. and Canada: www.metro.com/contactus

L03-227
Printed in U.S.A. 1/21

Information and specifications are subject to change without notice. Please confirm at time of order.

Copyright © 2021 InterMetro Industries Corp.



SmartLever™ Productivity System

17.30



SmartLever™ Design Guidelines

SmartLever's flexibility comes from its unique, patented design. It's a modular system of Uprights, Legs, Cross Bracing, Arm, Shelves, Work Surfaces, and Accessories that gives you the ability to optimize storage and workspace throughout your facility.

Uprights & Legs

SmartLever's strength comes from its robust Upright and Leg System. Legs bolt to the upright and can be ordered separately or as part of our convenient Starter and Add-On Kits. Uprights allow Shelves to be adjusted and position on 2" (51mm) increments.

Part #	Description
SMU76	76" (1930mm) SmartLever Upright
SMU86	86" (2184mm) SmartLever Upright

Part #	Description
SML18	18" (457mm) Nominal SmartLever Leg
SML21	21" (533mm) Nominal SmartLever Leg
SML24	24" (610mm) Nominal SmartLever Leg
SML30	30" (762mm) Nominal SmartLever Leg

Legs must always be equal to or longer than the longest Arm used for Shelves and/or Worksurfaces.

Examples:

- 30" Legs must be used on any unit with 30" Arms
- 24" Legs on any unit with 24" Arms
- 21" Legs on any unit with 21" Arms
- 18" Legs on any unit with 18" Arms



Cross Brace Kits

SmartLever's stability comes from its Cross Bracing System. Each Cross Brace Kit which consists of two Cross Bars and a set of Cross Bracing.

Part #	Description
SMB24	24" (610mm) Nominal SmartLever Cross Brace Kit w/Hardware
SMB30	30" (762mm) Nominal SmartLever Cross Brace Kit w/Hardware
SMB36	36" (914mm) Nominal SmartLever Cross Brace Kit w/Hardware
SMB42	42" (1067mm) Nominal SmartLever Cross Brace Kit w/Hardware
SMB48	48" (1219mm) Nominal SmartLever Cross Brace Kit w/Hardware
SMB54	54" (1372mm) Nominal SmartLever Cross Brace Kit w/Hardware
SMB60	60" (1524mm) Nominal SmartLever Cross Brace Kit w/Hardware
SMB72	72" (1829mm) Nominal SmartLever Cross Brace Kit w/Hardware

Arms

SmartLever's **Patent Pending** Arm Design holds heavy loads, is more durable, can hold different width shelves on the same arm, and come with ArmKeepers installed for the ultimate in adjustability and security. Sold as pairs or as singles ("-ADD" parts) SmartLever Arms also come with Shelf Mounting Hooks and Locking Wedges.

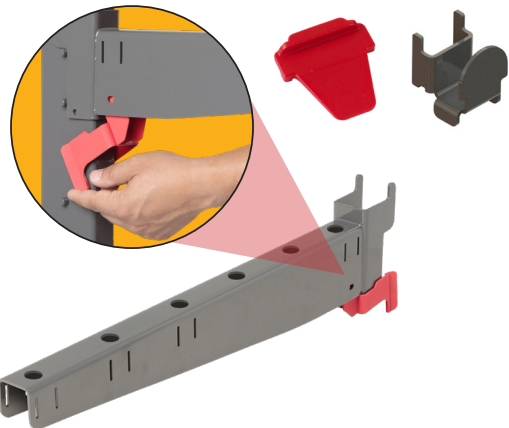

Part #	Description	# of Arms	# of Shelf Mount Hooks	# of Locking Wedges
SMA14A	Pair 14" (356mm) SmartLever Arms	2	4	4
SMA14A-ADD	Single 14" (356mm) SmartLever Arm	1	4	4
SMA18A	Pair 18" (457mm) SmartLever Arms	2	4	4
SMA18A-ADD	Single 18" (457mm) SmartLever Arm	1	4	4
SMA21A	Pair 21" (533mm) SmartLever Arms	2	4	4
SMA21A-ADD	Single 21" (533mm) SmartLever Arm	1	4	4
SMA24A	Pair 24" (610mm) SmartLever Arms	2	4	4
SMA24A-ADD	Single 24" (610mm) SmartLever Arm	1	4	4
SMA30A	Pair 30" (762mm) SmartLever Arms	2	4	4
SMA30A-ADD	Single 30" (762mm) SmartLever Arm	1	4	4

SmartLever™ Design Guidelines Cont.

Shelves

SmartLever's ultimate flexibility comes from the use of Standard Metro Shelving. All Super Erecta (round post) shelves work with SmartLever's Shelf Mounting Hooks.

1. Select Super Erecta Pro shelving for all-around superior performance in all environments based on its easy-to-clean removable mat designs and inherent corrosion protection.
2. Choose Super Erecta for basic applications. Metroseal is recommended but all wire shelving finishes are compatible
3. Utilize Super Erecta Solid Shelving for hybrid work surfaces, work surface overhead shelves, or anytime spill mitigation is important. Stainless steel is recommended for use with SmartLever but all solid shelving styles are compatible
4. Super Erecta Dunnage hold heavy loads supported on SmartLever's Legs with the used of Single or Double Leg Hooks (also for use with other style shelves mounted on the Legs of the unit). Dunnage shelves hold 1,000 lbs. (454kg) when mounted to Legs using Leg Hook (must order separately – see below) and 600 lbs. (272kg) when mounted to Arms.



Super Erecta Pro



Super Erecta Solid Stainless Steel

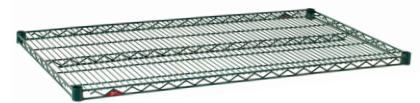

Super Erecta MetroSeal 3

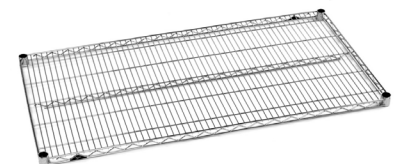

Super Erecta Stainless Steel, Brite or Chrome Finish

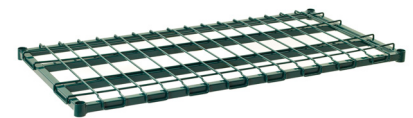

Super Erecta MetroSeal 3 Dunnage

Shelving Size L x W in. (mm)		Super Erecta Pro	Super Erecta Solid Stainless	Super Erecta Metroseal	Super Erecta Super Brite	Super Erecta Chrome	Super Erecta Stainless	Super Erecta Metroseal Dunnage
14" (356)	24" (610)	-	1424FS	1424NK3	1424BR	1424NC	1424NS	-
14" (356)	30" (762)	-	1430FS	1430NK3	1430BR	1430NC	1430NS	-
14" (356)	36" (914)	-	1436FS	1436NK3	1436BR	1436NC	1436NS	-
14" (356)	42" (1067)	-	1442FS	1442NK3	1442BR	1442NC	1442NS	-
14" (356)	48" (1219)	-	1448FS	1448NK3	1448BR	1448NC	1448NS	-
14" (356)	54" (1372)	-	-	1454NK3	1454BR	1454NC	1454NS	-
14" (356)	60" (1524)	-	1460FS	1460NK3	1460BR	1460NC	1460NS	-
14" (356)	72" (1829)	-	-	1472NK3	1472BR	1472NC	1472NS	-
18" (457)	24" (610)	PR1824NK3	1824FS	1824NK3	1824BR	1824NC	1824NS	1824DRK3
18" (457)	30" (762)	PR1830NK3	1830FS	1830NK3	1830BR	1830NC	1830NS	1830DRK3
18" (457)	36" (914)	PR1836NK3	1836FS	1836NK3	1836BR	1836NC	1836NS	1836DRK3
18" (457)	42" (1067)	PR1842NK3	1842FS	1842NK3	1842BR	1842NC	1842NS	1842DRK3
18" (457)	48" (1219)	PR1848NK3	1848FS	1848NK3	1848BR	1848NC	1848NS	1848DRK3
18" (457)	54" (1372)	PR1854NK3	-	1854NK3	1854BR	1854NC	1854NS	1854DRK3
18" (457)	60" (1524)	PR1860NK3	1860FS	1860NK3	1860BR	1860NC	1860NS	1860DRK3
18" (457)	72" (1829)	PR1872NK3	1872FS	1872NK3	1872BR	1872NC	1872NS	-
21" (533)	24" (610)	PR2124NK3	2124FS	2124NK3	2124BR	2124NC	2124NS	2124DRK3
21" (533)	30" (762)	PR2130NK3	2130FS	2130NK3	2130BR	2130NC	2130NS	2130DRK3
21" (533)	36" (914)	PR2136NK3	2136FS	2136NK3	2136BR	2136NC	2136NS	2136DRK3
21" (533)	42" (1067)	PR2142NK3	2142FS	2142NK3	2142BR	2142NC	2142NS	2142DRK3
21" (533)	48" (1219)	PR2148NK3	2148FS	2148NK3	2148BR	2148NC	2148NS	2148DRK3
21" (533)	54" (1372)	PR2154NK3	-	2154NK3	2154BR	2154NC	2154NS	2154DRK3
21" (533)	60" (1524)	PR2160NK3	2160FS	2160NK3	2160BR	2160NC	2160NS	2160DRK3
21" (533)	72" (1829)	PR2172NK3	-	2172NK3	2172BR	2172NC	2172NS	-
24" (610)	24" (610)	PR2424NK3	2424FS	2424NK3	2424BR	2424NC	2424NS	2424DRK3
24" (610)	30" (762)	PR2430NK3	2430FS	2430NK3	2430BR	2430NC	2430NS	2430DRK3
24" (610)	36" (914)	PR2436NK3	2436FS	2436NK3	2436BR	2436NC	2436NS	2436DRK3
24" (610)	42" (1067)	PR2442NK3	2442FS	2442NK3	2442BR	2442NC	2442NS	2442DRK3
24" (610)	48" (1219)	PR2448NK3	2448FS	2448NK3	2448BR	2448NC	2448NS	2448DRK3
24" (610)	54" (1372)	PR2454NK3	-	2454NK3	2454BR	2454NC	2454NS	2454DRK3
24" (610)	60" (1524)	PR2460NK3	2460FS	2460NK3	2460BR	2460NC	2460NS	2460DRK3
24" (610)	72" (1829)	PR2472NK3	2472FS	2472NK3	2472BR	2472NC	2472NS	-
30" (762)	36" (914)	-	-	3036NK3	-	3036NC	3036NS	-
30" (762)	42" (1067)	-	-	3042NK3	-	3042NC	-	-
30" (762)	48" (1219)	-	-	3048NK3	-	3048NC	3048NS	-
30" (762)	54" (1372)	-	-	3054NK3	-	3054NC	-	-
30" (762)	60" (1524)	-	-	3060NK3	-	3060NC	3060NS	-
30" (762)	72" (1829)	-	-	3072NK3	-	3072NC	3072NS	-

Leg Hooks

Leg hooks are used to install any shelf on the legs as the bottom shelf of the unit.



Cat. No.	Description
LSH1	Single Leg Hook (4 Pack)
LSH2	Double Leg Hook (2 Pack)

*Arm size must match shelf depth. For example, 2148NK3 shelf will use SMA 21A.



SmartLever™ Design Guidelines Cont.

Work Surfaces

Create a versatile and productive work station with SmartLever Work Surfaces. Work Surfaces are 304 16ga Stainless Steel with a 4" (102mm) seamless back splash and mount over 30" (762mm) Shelves (30" (762mm) Arms and 30" (762mm) deep Shelves must be ordered separately with the work surface). Work surface heights can be set at any height in 2" (51mm) increments for optimal ergonomics and work flow. Work surfaces include a sound deadening inlay and support 600lbs. (272kg) evenly distributed.

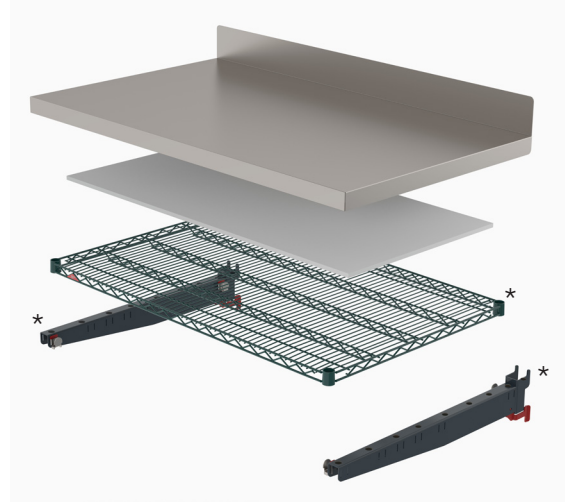

Cat. No.	Description	Approx. Pkd. Wt. lbs. (kg)	Width in. (mm)	Length in. (mm)
SMW36	SmartLever 30x36 SS Work Surface	33.6 (15.3)	30.25 (768)	39.75 (1010)
SMW42	SmartLever 30x42 SS Work Surface	38.3 (17.5)	30.25 (768)	45.75 (1162)
SMW48	SmartLever 30x48 SS Work Surface	42.9 (19.5)	30.25 (768)	51.75 (1314)
SMW54	SmartLever 30x54 SS Work Surface	47.6 (21.3)	30.25 (768)	57.75 (1467)
SMW60	SmartLever 30x60 SS Work Surface	52.2 (23.8)	30.25 (768)	63.75 (1619)
SMW72	SmartLever 30x72 SS Work Surface	61.4 (28)	30.25 (768)	75.75 (1924)

*Work surfaces need a 30" deep shelf and a pair of 30" arms, which must be ordered separately.

SmartWall Grids & Brackets

SmartWall Grids can be added to SmartLever Work Stations to accommodate SmartWall Accessories (See SmartWall Accessories Spec Sheet 10.43) for the ultimate in customized productivity!



* Shown with SmartWall Accessories (Not included within specifications)

Accessory Grids

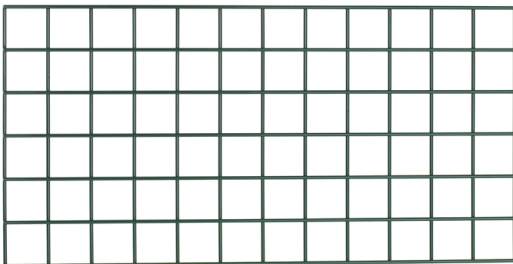

Width	Length	MetroSeal 3 Part #
18" (457)	24" (610)	WG1824K3
18" (457)	30" (762)	WG1830K3
18" (457)	36" (914)	WG1836K3
18" (457)	42" (1067)	WG1842K3
18" (457)	48" (1219)	WG1848K3
18" (457)	54" (1372)	WG1854K3
18" (457)	60" (1524)	WG1860K3
18" (457)	72" (1829)	WG1872K3
24" (610)	36" (914)	WG2436K3
24" (610)	48" (1219)	WG2448K3
30" (762)	36" (914)	WG3036K3
30" (762)	48" (1219)	WG3048K3

Grid Bracket

Cat. No.	Description
SMR*	SmartLever Grid Bracket (4 pack)

*must be purchased if ordering a grid.



SmartLever™ Design Guidelines Cont.

Starter & Add-on Kits

Starter kits include: two uprights, two legs, two cross bars, and cross bracing

Add-On kits include: one upright, one leg, two cross bars, and cross bracing

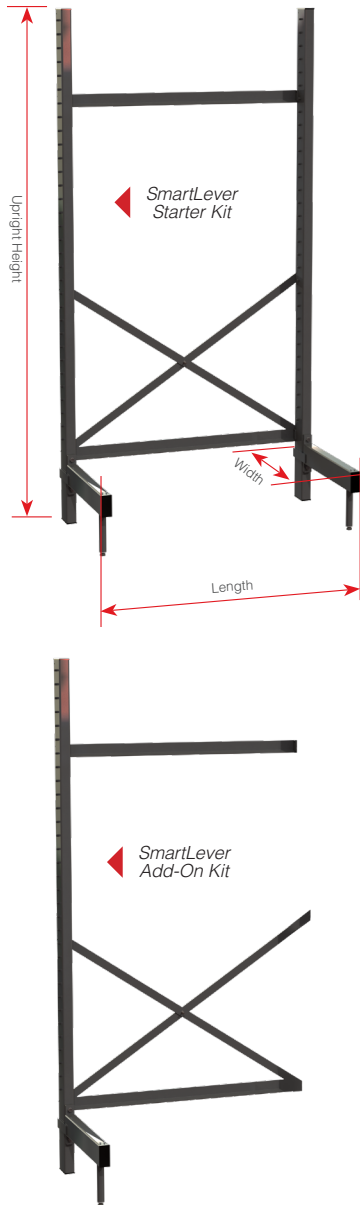

Unit H (in.) (mm)	Unit W (in.) (mm)	SmartLever Starter Kit	Starter Kit L (in.) (mm)	SmartLever Add-On Kit	Add-On Kit L (in.) (mm)	Shelf Size							
						L (in.) (mm)	W (in.) (mm)	L (in.) (mm)	W (in.) (mm)				
76.38	1940	22.5	572	SM761824-KIT	28.25	718	SM761824-ADD	26.19	665	18	457	24	610
76.38	1940	22.5	572	SM761830-KIT	34.25	870	SM761830-ADD	32.19	818	18	457	30	762
76.38	1940	22.5	572	SM761836-KIT	40.25	1022	SM761836-ADD	38.19	970	18	457	36	914
76.38	1940	22.5	572	SM761842-KIT	46.25	1175	SM761842-ADD	44.19	1122	18	457	42	1067
76.38	1940	22.5	572	SM761848-KIT	52.25	1327	SM761848-ADD	50.19	1275	18	457	48	1219
76.38	1940	22.5	572	SM761854-KIT	58.25	1480	SM761854-ADD	56.19	1427	18	457	54	1372
76.38	1940	22.5	572	SM761860-KIT	64.25	1632	SM761860-ADD	62.19	1580	18	457	60	1524
76.38	1940	22.5	572	SM761872-KIT	76.25	1937	SM761872-ADD	74.19	1884	18	457	72	1829
76.38	1940	25.5	648	SM762124-KIT	28.25	718	SM762124-ADD	26.19	665	21	533	24	610
76.38	1940	25.5	648	SM762130-KIT	34.25	870	SM762130-ADD	32.19	818	21	533	30	762
76.38	1940	25.5	648	SM762136-KIT	40.25	1022	SM762136-ADD	38.19	970	21	533	36	914
76.38	1940	25.5	648	SM762142-KIT	46.25	1175	SM762142-ADD	44.19	1122	21	533	42	1067
76.38	1940	25.5	648	SM762148-KIT	52.25	1327	SM762148-ADD	50.19	1275	21	533	48	1219
76.38	1940	25.5	648	SM762154-KIT	58.25	1480	SM762154-ADD	56.19	1427	21	533	54	1372
76.38	1940	25.5	648	SM762160-KIT	64.25	1632	SM762160-ADD	62.19	1580	21	533	60	1524
76.38	1940	25.5	648	SM762172-KIT	76.25	1937	SM762172-ADD	74.19	1884	21	533	72	1829
76.38	1940	28.5	724	SM762424-KIT	28.25	718	SM762424-ADD	26.19	665	24	610	24	610
76.38	1940	28.5	724	SM762430-KIT	34.25	870	SM762430-ADD	32.19	818	24	610	30	762
76.38	1940	28.5	724	SM762436-KIT	40.25	1022	SM762436-ADD	38.19	970	24	610	36	914
76.38	1940	28.5	724	SM762442-KIT	46.25	1175	SM762442-ADD	44.19	1122	24	610	42	1067
76.38	1940	28.5	724	SM762448-KIT	52.25	1327	SM762448-ADD	50.19	1275	24	610	48	1219
76.38	1940	28.5	724	SM762454-KIT	58.25	1480	SM762454-ADD	56.19	1427	24	610	54	1372
76.38	1940	28.5	724	SM762460-KIT	64.25	1632	SM762460-ADD	62.19	1580	24	610	60	1524
76.38	1940	28.5	724	SM762472-KIT	76.25	1937	SM762472-ADD	74.19	1884	24	610	72	1829
76.38	1940	34.5	876	SM763024-KIT	28.25	718	SM763024-ADD	26.19	665	30	762	24	610
76.38	1940	34.5	876	SM763030-KIT	34.25	870	SM763030-ADD	32.19	818	30	762	30	762
76.38	1940	34.5	876	SM763036-KIT	40.25	1022	SM763036-ADD	38.19	970	30	762	36	914
76.38	1940	34.5	876	SM763042-KIT	46.25	1175	SM763042-ADD	44.19	1122	30	762	42	1067
76.38	1940	34.5	876	SM763048-KIT	52.25	1327	SM763048-ADD	50.19	1275	30	762	48	1219
76.38	1940	34.5	876	SM763054-KIT	58.25	1480	SM763054-ADD	56.19	1427	30	762	54	1372
76.38	1940	34.5	876	SM763060-KIT	64.25	1632	SM763060-ADD	62.19	1580	30	762	60	1524
76.38	1940	34.5	876	SM763072-KIT	76.25	1937	SM763072-ADD	74.19	1884	30	762	72	1829
86.38	2194	22.5	572	SM861824-KIT	28.25	718	SM861824-ADD	26.19	665	18	457	24	610
86.38	2194	22.5	572	SM861830-KIT	34.25	870	SM861830-ADD	32.19	818	18	457	30	762
86.38	2194	22.5	572	SM861836-KIT	40.25	1022	SM861836-ADD	38.19	970	18	457	36	914
86.38	2194	22.5	572	SM861842-KIT	46.25	1175	SM861842-ADD	44.19	1122	18	457	42	1067
86.38	2194	22.5	572	SM861848-KIT	52.25	1327	SM861848-ADD	50.19	1275	18	457	48	1219
86.38	2194	22.5	572	SM861854-KIT	58.25	1480	SM861854-ADD	56.19	1427	18	457	54	1372
86.38	2194	22.5	572	SM861860-KIT	64.25	1632	SM861860-ADD	62.19	1580	18	457	60	1524
86.38	2194	22.5	572	SM861872-KIT	76.25	1937	SM861872-ADD	74.19	1884	18	457	72	1829
86.38	2194	25.5	648	SM862124-KIT	28.25	718	SM862124-ADD	26.19	665	21	533	24	610
86.38	2194	25.5	648	SM862130-KIT	34.25	870	SM862130-ADD	32.19	818	21	533	30	762
86.38	2194	25.5	648	SM862136-KIT	40.25	1022	SM862136-ADD	38.19	970	21	533	36	914
86.38	2194	25.5	648	SM862142-KIT	46.25	1175	SM862142-ADD	44.19	1122	21	533	42	1067
86.38	2194	25.5	648	SM862148-KIT	52.25	1327	SM862148-ADD	50.19	1275	21	533	48	1219
86.38	2194	25.5	648	SM862154-KIT	58.25	1480	SM862154-ADD	56.19	1427	21	533	54	1372
86.38	2194	25.5	648	SM862160-KIT	64.25	1632	SM862160-ADD	62.19	1580	21	533	60	1524
86.38	2194	25.5	648	SM862172-KIT	76.25	1937	SM862172-ADD	74.19	1884	21	533	72	1829
86.38	2194	28.5	724	SM862424-KIT	28.25	718	SM862424-ADD	26.19	665	24	610	24	610
86.38	2194	28.5	724	SM862430-KIT	34.25	870	SM862430-ADD	32.19	818	24	610	30	762
86.38	2194	28.5	724	SM862436-KIT	40.25	1022	SM862436-ADD	38.19	970	24	610	36	914
86.38	2194	28.5	724	SM862442-KIT	46.25	1175	SM862442-ADD	44.19	1122	24	610	42	1067
86.38	2194	28.5	724	SM862448-KIT	52.25	1327	SM862448-ADD	50.19	1275	24	610	48	1219
86.38	2194	28.5	724	SM862454-KIT	58.25	1480	SM862454-ADD	56.19	1427	24	610	54	1372
86.38	2194	28.5	724	SM862460-KIT	64.25	1632	SM862460-ADD	62.19	1580	24	610	60	1524
86.38	2194	28.5	724	SM862472-KIT	76.25	1937	SM862472-ADD	74.19	1884	24	610	72	1829
86.38	2194	34.5	876	SM863024-KIT	28.25	718	SM863024-ADD	26.19	665	30	762	24	610
86.38	2194	34.5	876	SM863030-KIT	34.25	870	SM863030-ADD	32.19	818	30	762	30	762
86.38	2194	34.5	876	SM863036-KIT	40.25	1022	SM863036-ADD	38.19	970	30	762	36	914
86.38	2194	34.5	876	SM863042-KIT	46.25	1175	SM863042-ADD	44.19	1122	30	762	42	1067
86.38	2194	34.5	876	SM863048-KIT	52.25	1327	SM863048-ADD	50.19	1275	30	762	48	1219
86.38	2194	34.5	876	SM863054-KIT	58.25	1480	SM863054-ADD	56.19	1427	30	762	54	1372
86.38	2194	34.5	876	SM863060-KIT	64.25	1632	SM863060-ADD	62.19	1580	30	762	60	1524
86.38	2194	34.5	876	SM863072-KIT	76.25	1937	SM863072-ADD	74.19	1884	30	762	72	1829



SmartLever™ Productivity System

We put space to work.®

Specifications

- Structure: Heavy gauge cold rolled steel electroplated and epoxy coated with stainless steel hardware.
- Work Surface: 16 gauge, type 304 stainless steel top with Duraplast anti-drumming support.
- Support Arms: 11 gauge, steel coated with epoxy.
- Dunnage: heavy gauge cold rolled steel electroplated and epoxy coated
- General: work surface and shelving height adjustable on 2" (51mm) increments.
- Warranty: 10 year limited warranty against surface rust formation.
- Load Capacity:
 - The total weight load capacity of each model including the bottom shelf, is 2,800 lbs. (1270kg).
 - Each level (work surface or shelf) has an evenly distributed weight load capacity of 600 lbs. (272kg).
 - The maximum uniformly distributed load on the Dunnage rack must not exceed 1,000 lbs. (454kg).

Configuring SmartLever™

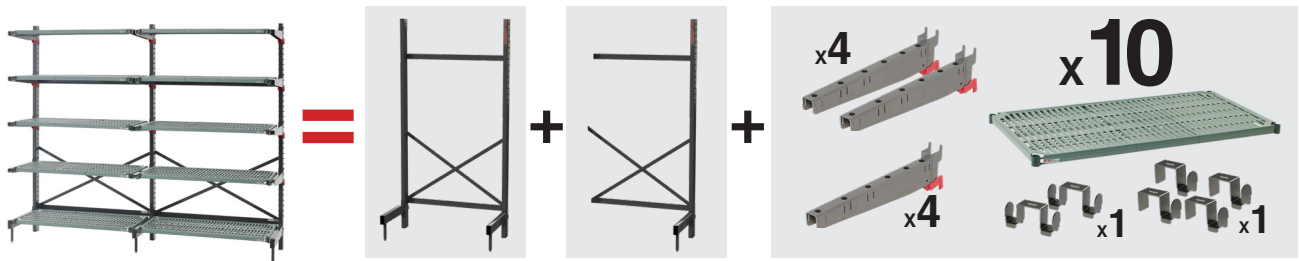

Quantity Needed	Cat. No.	Description
1	SM762148-KIT	SmartLever 21x48 Starter Unit Kit
1	SM762148-ADD	SmartLever 21x48 Add-on Unit Kit
4	SMA21A	Pair 21" SmartLever Arms

Quantity Needed	Cat. No.	Description
4	SMA21A-ADD	Single 21" SmartLever Arms
10	PR2148NK3	21x48 Super Erecta Pro Shelf
1	LSH1	Single Leg Hook (4 Pack)
1	LSH2	Double Leg Hook (2 Pack)

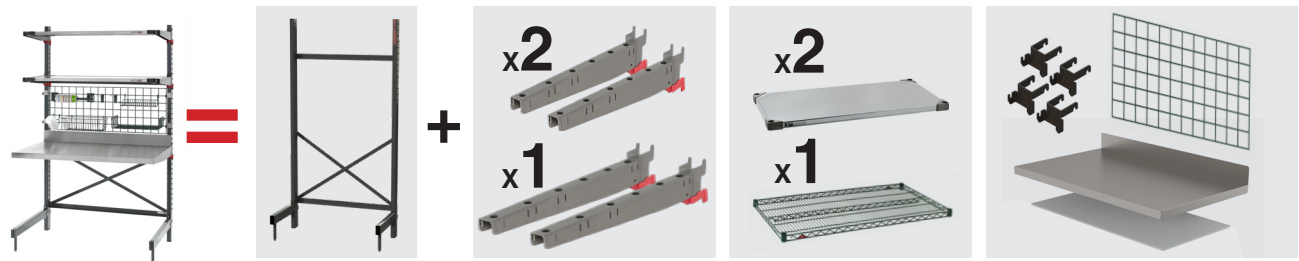

Quantity Needed	Cat. No.	Description
1	SM763042-KIT	SmartLever 30x42 Starter Unit Kit
1	SMW42	SmartLever 30x42 SS Work Surface
1	3042NK3	30x42 Epoxy Coated Wire Shelf
2	SMA18A	Pair 18" SmartLever Arms

Quantity Needed	Cat. No.	Description
1	SMA30A	Pair 30" SmartLever Arms
1	WG1842K3	18x42 SmartWall Accessory Grid
1	SMR	SmartLever Grid Bracket (4 pack)
2	1842FS	18x42 Flat Stainless Steel Shelf

Note: Grid accessories are not included and can be ordered separately

an Ali Group Company



The Spirit of Excellence