

SHALLOW DEPTH BASE UNDERCOUNTER REFRIGERATOR

Model: RA60SN-U

Natural Refrigerant R-290 Model

60" Shallow Depth Base Undercounter Refrigerator with Solid Doors



ENERGY STAR® Qualified Commercial Refrigerator

Heavy gauge #300 series stainless steel top, stainless steel front and end panels, galvanized steel rear and grills and aluminum interior.



Options and Accessories

(upcharge and lead times may apply)

| | |
|---|--|
| Stainless steel interior | Condensing unit left (standard on right) |
| Stainless steel back | Door Locks |
| Additional epoxy coated steel shelves | |
| Stainless Steel Shelves | |
| Drawer in lieu of door section above the condensing unit* | |
| Drawers in lieu of doors (consult factory)** | |

Consult factory for other model configurations, options and accessories.

*Drawer section above condensing unit holds (4) 1/6 pans

**Two tier (larger section): (1) 12 x 20 x 6 pan per drawer

**Two Narrow: (4) 1/6 pans per drawer



Project Name:

Model Specified:

Location:

Item No:

Quantity:

AIA #:

SIS #:

Standard Model Features

REFRIGERATION SYSTEM

Performance rated refrigeration system

Natural, environmentally safe, high efficiency R-290 refrigerant¹

Unique forced air design utilizes fans (approx. every 12") across the entire back of unit for even distribution of cold

Automatic, hot gas condensate evaporator

Non-corrosive, plasticized fin evaporator coil

Easily serviceable, slide out condensing unit

Expansion valve system

CABINET ARCHITECTURE

2" non-CFC polyurethane foam insulation

Smooth, polished chrome door handles

Spring loaded, self closing doors

Magnetic snap in Santoprene™ door gaskets

Heavy duty, epoxy coated steel shelves

Completely enclosed, vented and removable rear and side grills

1 3/8" diameter plate casters, mounted on heavy-duty support plates (easily field installed)

MODEL FEATURES

Refrigerated section with door above the condensing unit

Electronic control, off-cycle defrost

Reversing condenser fan motor (runs for short period during startup to clear any debris)

Front breather air divider (field installed)

Field rehingeable doors

¹ R-290 refrigerant meets all federal and state regulatory requirements.

NOTE: Models come standard with a door above the condensing unit. A drawer above the condensing unit is an option.

APPROVAL:

Model Specifications

DIMENSIONAL DATA

| | |
|--|-----------------|
| Net Capacity (cubic feet) | 15.2 (430 l) |
| Width, Overall (inches) | 60 (1529 mm) |
| Depth, Overall (inches) (including handles & bumpers) | 31 (770 mm) |
| Height, Overall (inches) (including 1 3/8" casters) | 32 (806 mm) |
| Shelf Area (square feet) | 5.68 (0.5 sq m) |
| Number of Shelves | 4 |
| Number of Full Doors | 2 |
| Number of Half Doors | 1 |
| Interior Depth (inches) | 24 (610 mm) |
| Interior Height (inches) | 26 (660 mm) |
| Interior Height (inches) (above condenser) | 12 1/2 (318 mm) |

REFRIGERANT DATA

| | |
|-------------------------------|------|
| Condensing Unit Size (H.P.) | 1/4 |
| R-290 Refrigerant Charge (oz) | 3.6 |
| Capacity (BTU per hour)* | 1930 |

ELECTRICAL DATA

| | |
|--|---------------------|
| Voltage (International) | 115/60/1 (220/50/1) |
| Total Amps (International) | 3.0 (1.5) |
| 10 ft. Cord/Plug [attached] (International) | Yes (No) |

SHIPPING DATA

| | |
|--------------------------|--------------|
| Weight (pounds) | 320 (145 kg) |
| Height - Crated (inches) | 45 (1194 mm) |
| Width - Crated (inches) | 69 (1575 mm) |
| Depth - Crated (inches) | 39 (1111 mm) |

* Rating @ +25°F evaporator, 90°F ambient
 Figures in parentheses reflect metric equivalents rounded to the nearest whole unit.



Equipped with one NEMA-5-15P Plug
(varies by country)

Model Plan Views

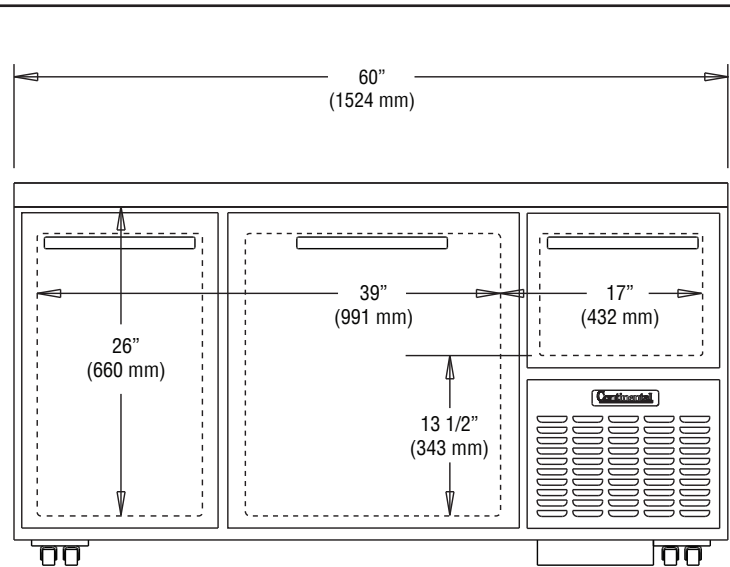

FRONT VIEW

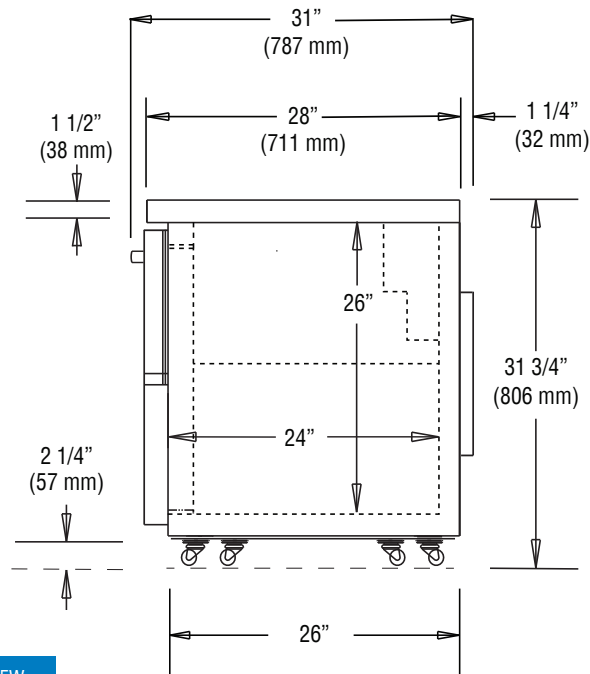

SIDE VIEW

Continental[®]

Refrigerator

Toll-Free: 800-523-7138
 Phone: 215-244-1400
 Fax: 215-244-9579

539 Dunkserry Road
 Bensalem, PA 19020
www.continentalrefrigerator.com

Due to our continued efforts in developing innovative products, specifications subject to change without notice.



PROUDLY
 DESIGNED & ASSEMBLED
 IN THE U.S.A.

Intertek

© Copyright 2021. Continental Refrigerator.

REVISED: 4/30/26