



ELECTRIC STEAM TILTING KETTLE



Kettle shown with optional Spring Assist Cover and Draw-off valve

- KELT-20
- KELT-25
- KELT-30
- KELT-40
- KELT-60
- KELT-80
- KELT-100

OPERATION SHALL BE BY:

Electrically, self-generating closed steam system operating at 50 psi equipped for operation on:

- 208 VAC, 1 phase, 50/60 Hz (12 to 18 kW only)
- 208 VAC, 3 phase, 50/60 Hz
- 220 VAC, 1 phase, 50/60 Hz (12 to 18 kW only)
- 220 VAC, 3 phase, 50/60 Hz
- 240 VAC, 1 phase, 50/60 Hz (12 to 18 kW only)
- 240 VAC, 3 phase, 50/60 Hz
- 380/220 VAC, 3 phase, 4 wire, 50/60 Hz
- 415/240 VAC, 3 phase, 4 wire, 50/60 Hz

OPTIONS & ACCESSORIES AT ADDITIONAL COST

- | | | |
|---|---|---|
| <input type="checkbox"/> 380 VAC, 3 phase, 50/60 Hz. | <input type="checkbox"/> Etched litre markings (LM-) | <input type="checkbox"/> Solid disc for draw off (TSS-) |
| <input type="checkbox"/> 415 VAC, 3 phase, 50/60 Hz. | <input type="checkbox"/> Correctional package | <input type="checkbox"/> Contoured measuring strip (CMS-) |
| <input type="checkbox"/> 480 VAC, 3 phase, 50/60 Hz. | <input type="checkbox"/> Single pantry faucet with an 18" swing spout (SF-18) | <input type="checkbox"/> Strainer hook (SH-) |
| <input type="checkbox"/> 600 VAC, 3 phase, 50/60 Hz | <input type="checkbox"/> Double pantry faucet with an 18" swing spout (DF-18) | <input type="checkbox"/> Pan support (PC-1) |
| <input type="checkbox"/> 24 kW on 40, 60, 80 gallon | <input type="checkbox"/> Single pantry faucet with 18" swing spout and 68" spray hose and bracket (SF-RSH-18) | <input type="checkbox"/> Pour lip strainer (TKS-) |
| <input type="checkbox"/> 33 kW on 60, 80, 100 gallon | <input type="checkbox"/> Double pantry faucet with 18" swing spout and 68" spray hose and bracket (DF-RSH-18) | <input type="checkbox"/> Draw-off valve hose kit (DVHK-) |
| <input type="checkbox"/> 2" (50 mm) draw-off valve with perforated strainer (TVT-2) | <input type="checkbox"/> One piece lift off stainless steel cover (C-) | <input type="checkbox"/> Calibrated thermostat dial, "F" |
| <input type="checkbox"/> 3" (76 mm) draw-off valve with perforated strainer (TVT-3) | <input type="checkbox"/> Triple basket assembly (TBA-) | <input type="checkbox"/> Calibrated thermostat dial, "C" |
| <input type="checkbox"/> Spring assist hinged stainless steel cover (CH-) | | <input type="checkbox"/> Kettle heat shield (KHS-) |
| <input type="checkbox"/> Etched gallon markings (GM-) | | |

STANDARD CONSTRUCTION SPECIFICATIONS

Shall be a Southbend Steam model KELT-20, KELT-25, KELT-30, KELT-40, KELT-60, KELT-80 or KELT-100, self-generating, electric tilting kettle.

A double wall kettle interior shall form a steam jacket around the lower 2/3 of the kettle. The jacket enclosure shall contain distilled water which is factory sealed.

The bottom of the kettle shall be of hemispherical design for superior heat circulation.

The console shall be drip proof, stainless steel clad and shall be supported on all welded, 1-5/8" (41 mm) diameter stainless steel pipe frame and legs fitted with 4 hole adjustable flanged feet for securing to floor.

The kettle shall pivot on a trunnion connected to the tilt mechanism and the out-bore bearing connected to the frame and shall permit the kettle to tilt forward a full 90° for complete emptying.

The tilt mechanism shall be self locking for positive stop action. Construction shall be all welded #4 finish stainless steel, type 304.

The interior liner shall be standard stainless steel type 316 for high acid content cooking.

The controls shall be integrally mounted and shall include a power switch, thermostat, pilot light, low water light, vacuum/pressure gauge, safety relief valve, and low water shut off.

Faucet bracket standard.

The kettle shall be standard with removable elements.

The kettle shall operate in a temperature range of 165°F to 285°F (74°C to 140°C) at a maximum pressure of 50 psi (345kPa).



Approval Notes: _____

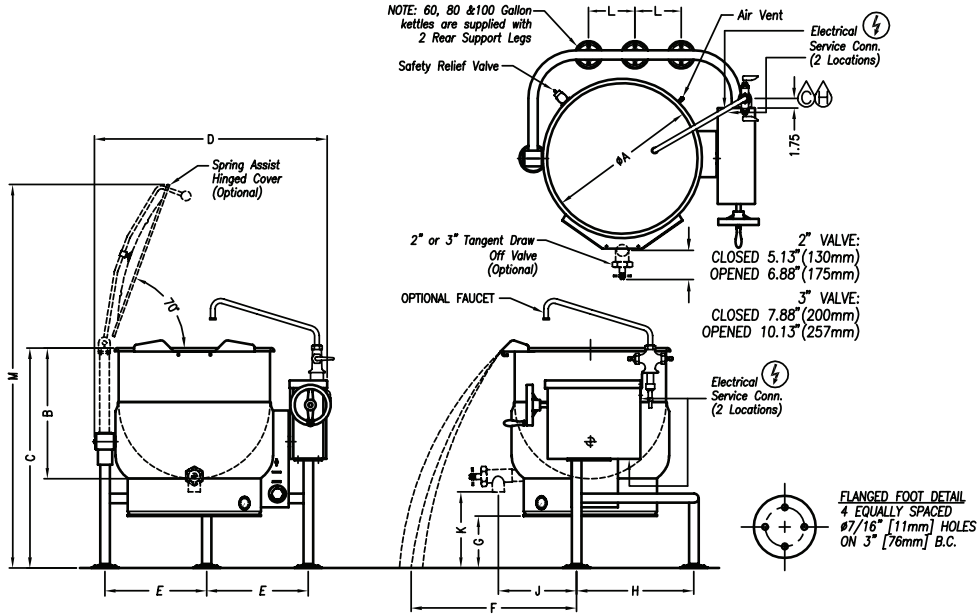

SERVICE CONNECTIONS

- ELECTRICAL CONNECTION : Unless otherwise specified, field wire electrical connection to be 120 volts, 60 Hz, 1 phase with grounding wire. Unit furnished with 6' cord and 3 prong plug. Total maximum amps 4.0.
- COLD WATER: 3/8" (10 mm) tubing to faucet (optional)
- HOT WATER: 3/8" (10 mm) tubing to faucet (optional)

DIMENSIONS

MODEL	CAPACITY	UNITS	A	B	C	D	E	F	G	H	J(2")	J(3")	K(2")	K(3")	L	M
KELT-20	20 gallons (76 liters)	in (mm)	21" (533)	18" (457)	38" (965)	36" (914)	15" (381)	18" (457)	14" (356)	17.75" (450)	11.45" (290)	15.5" (394)	18" (457)	17.5" (445)	N/A	63.5" (1613)
KELT-25	25 gallons (95 liters)	in (mm)	21" (533)	21.25" (540)	37.25" (946)	36" (914)	15" (381)	18" (457)	9.5" (241)	17.75" (450)	11.45" (290)	13.13" (333)	14.38" (365)	17.13" (435)	N/A	64.62" (1642)
KELT-30	30 gallons (114 liters)	in (mm)	24" (610)	20" (508)	38" (965)	39" (990)	16.5" (419)	19" (483)	12.38" (314)	19.25" (489)	16.75" (425)	17.25" (438)	16" (406)	15.5" (394)	N/A	66.5" (1689)
KELT-40	40 gallons (152 liters)	in (mm)	26" (660)	22.5" (572)	38" (965)	41" (1041)	17.5" (445)	23" (584)	10" (254)	20.25" (514)	17.5" (445)	18.5" (470)	13.5" (343)	13" (330)	N/A	68.5" (1740)
KELT-60	60 gallons (227 liters)	in (mm)	29.5" (749)	26" (660)	42" (1067)	44.5" (1130)	19.13" (486)	24" (610)	11" (280)	22.25" (565)	19.5" (495)	20.75" (527)	14" (356)	13.5" (343)	10.5" (267)	76" (1930)
KELT-80	80 gallons (303 liters)	in (mm)	33" (838)	28" (711)	45" (1143)	48" (1219)	20.88" (530)	27" (686)	12.63" (321)	23.75" (603)	20.25" (514)	21.25" (540)	15" (381)	14.5" (368)	12" (305)	82.5" (2096)
KELT-100	100 gallons (379 liters)	in (mm)	35.5" (902)	29.75" (755)	48.75" (1238)	49.5" (1257)	22.25" (565)	32" (813)	14.5" (368)	25.25" (641)	20.25" (514)	21.25" (540)	18.75" (476)	18.25" (464)	14" (356)	88.5" (2248)

ELECTRICAL CHARACTERISTIC

AVAILABLE kW			AMPS PER LINE								
MODEL	STANDARD	OPTIONAL	kW	PHASE	208V	220V	240V	380V	415V	480V	600V
KELT-[20,25]	12	N/A	12	1	57.7	54.5	50.0	N/A	N/A	N/A	N/A
KELT-30	15	N/A		3	33.3	31.5	28.9	18.2	16.7	14.4	11.6
KELT-40	18	24	15	1	72.1	68.2	62.5	N/A	N/A	N/A	N/A
KELT-60	18	24 or 33		3	41.6	39.4	36.1	22.8	20.9	18.0	14.5
KELT-80	18	24 or 33	18	1	86.5	81.8	75.0	N/A	N/A	N/A	N/A
KELT-100	24	33		3	50.0	47.2	43.3	27.3	25.0	21.7	21.7
			24	3	66.6	63.0	57.7	36.5	33.4	28.9	23.1
			33	3	91.6	86.6	79.4	50.1	45.9	39.7	31.8

SPECIFICATIONS

MODEL	SHIPPING WEIGHT	MINIMUM CLEARANCE		CAPACITY		MODEL	SHIPPING WEIGHT	MINIMUM CLEARANCE		CAPACITY	
KELT-20	296 lbs. [134 kg]	SIDES BACK	0" [0 mm] 0" [0 mm]	20 Gallon	76 Liter	KELT-60	417 lbs. [189 kg]	SIDES BACK	0" [0 mm] 0" [0 mm]	60 Gallon	227 Liter
KELT-25	300 lbs. [136 kg]			25 Gallon	94 Liter	KELT-80	520 lbs. [236 kg]			80 Gallon	303 Liter
KELT-30	313 lbs. [142 kg]			30 Gallon	114 Liter	KELT-100	630 lbs. [286 kg]			100 Gallon	379 Liter
KELT-40	352 lbs. [160 kg]			40 Gallon	152 Liter						

**INTENDED FOR COMMERCIAL USE ONLY.
NOT FOR HOUSEHOLD USE.**

