

Handler Series Utility Carts

Stainless Steel Heavy Duty - 700 Lb. Capacity

Models

4710, 4711, 4721, 4722

4743, 4744, 4758, 4759

4510, 4511, 4521, 4522

4543, 4544, 4558, 4559



Model 4743

The Smart Ergonomic Choice For Maneuvering In Confined Spaces

- Durable U-frame unitized, electronically welded angle leg construction
- One-piece ergonomic push handle
- 700 lb. (320 kg.) load capacity
- 18-gauge stainless steel reinforced shelves
- Corner bumpers on front legs protect furnishings
- Sound deadening panels under shelves reduce vibrations and noise
- 5" swivel non-marking casters

Spec. #

AIA #

Specifications

Unit shall be of fully welded stainless steel construction. Legs and frame shall be of U-frame design, eliminating the need for corner reinforcements. Leg/frame shall be .120 x 1" x 1" angle stainless steel. Shelves shall be of 18-gauge stainless steel and shall be welded to vertical leg frames. Shelves shall be double hemmed on all four edges for extra rigidity. One-piece tubular stainless steel ergonomic handle is shipped unassembled. Unit shall have two each 6" (152 mm) vertical bumpers riveted to front legs. Unit shall have four each 5" (127 mm) diameter extra-load swivel casters with 1-1/4" (32 mm) wide non-marking polyurethane wheels. Casters shall be plate type and shall be bolted to an 18-gauge 5" (127 mm) wide stainless steel cross member with a galvanized reinforcement.

Lakeside Manufacturing, Inc.

4900 West Electric Avenue • West Milwaukee, WI 53219 U.S.A.

800-558-8565 • 414-902-6400 • Fax 414-902-6446 • info@eLakeside.com • www.eLakeside.com/foodservice

Models

4710, 4711
 4721, 4722
 4743, 4744
 4758, 4759
 4510, 4511
 4521, 4522
 4543, 4544
 4558, 4559

Handler™ Series Utility Carts

Stainless Steel Heavy Duty - 700 Lb. Capacity

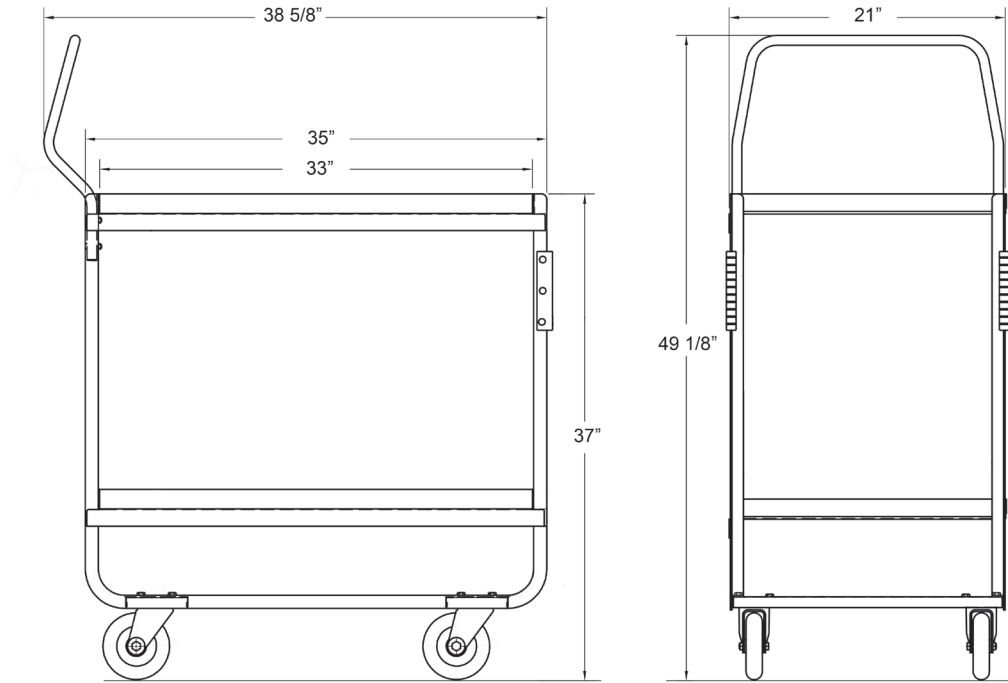

Model 4743

Model Information

Model	NSF Model	# of	Shelf Description		Top Shelf Height	Overall Size*			Case Weight	
			Size	Clearance		L	W	H	lbs.	(kg.)
4710	4510	2	15-1/2" x 24" (394 x 610)	19" (483)	32-3/4" (832)	30" (762)	16-1/4" (413)	46-3/4" (1188)	49	(22.2)
4711	4511	3	15-1/2" x 24" (394 x 610)	10" (254)	32-3/4" (832)	30" (762)	16-1/4" (413)	46-3/4" (1188)	57	(25.9)
4721	4521	2	18" x 27" (457 x 686)	19" (483)	32-3/4" (832)	32-5/8" (829)	19-3/8" (492)	46-3/4" (1188)	53	(24)
4722	4522	3	18" x 27" (457 x 686)	10" (254)	32-3/4" (832)	32-5/8" (829)	19-3/8" (492)	46-3/4" (1188)	63	(28.6)
4743	4543	2	21" x 33" (533 x 838)	21" (533)	35-1/2" (902)	38-5/8" (981)	22-3/8" (568)	49-1/8" (1248)	64	(29)
4744	4544	3	21" x 33" (533 x 838)	11-3/8" (289)	35-1/2" (902)	38-5/8" (981)	22-3/8" (568)	49-1/8" (1248)	78	(35.4)
4758	4558	2	21" x 49" (533 x 1245)	21" (533)	35-1/2" (902)	54-5/8" (1387)	22-3/8" (568)	49-1/8" (1248)	87	(39.5)
4759	4559	3	21" x 49" (533 x 1245)	11-3/8" (289)	35-1/2" (902)	54-5/8" (1387)	22-3/8" (568)	49-1/8" (1248)	108	(49)

Measurements in () denote metric millimeters, unless otherwise specified.
 *Including vertical handle.

Optional Accessories

- Perimeter extended bumper
- Brake casters (Set of 2)



Lakeside Manufacturing, Inc.
 4900 West Electric Avenue • West Milwaukee, WI 53219 U.S.A.
 800-558-8565 • 414-902-6400 • Fax 414-902-6446
 info@elakeside.com • www.elakeside.com/foodservice