

## SS686 Sentry Series Electric Restaurant Range

Project \_\_\_\_\_  
 Item \_\_\_\_\_  
 Quantity \_\_\_\_\_  
 CSI Section 11400  
 Approved \_\_\_\_\_  
 Date \_\_\_\_\_

### Models

- SS686
- S686 Griddle / Hot Top Only



Model SS686

### Standard Features

- Stainless Steel exterior
- One large, full-size oven with porcelain interior finish
- Removeable, 4-position, rack guides with one oven rack
- Electro-mechanical heavy-duty oven thermostat, (150°F/66°C - 550°F/288°C)
- Cool-touch oven door handle
- 10" (254mm) high stainless steel backguard with slotted black enameled angled cap
- 6" (152 mm) high stainless steel legs - adjustable
- 6 sealed, high-performance elements with overheat protection, individually controlled
- 1-year limited warranty on parts & labor (USA & Canada only)

### Options & Accessories

- Convection oven base (add suffix -RC) with 3-position rack guide assembly and 3 oven racks
- 5/8" (16mm) thick thermostatically controlled griddle plate available in 12", add suffix -12G, 24" add suffix -24G and 36", add suffix -36G, standard on the right, left optional
- Solid steel hot top 1/2" (13mm) thick utilizing front and rear switch controls, available in 12", add suffix -1, and 24" add suffix -2, standard on the left, right optional (Note: maximum of two (2) hot top sections per range.)
- Additional oven rack
- Set of (4) 5" high polyurethane non-marking swivel casters with front brakes.
- 17" (432mm) high stainless steel backguard with slotted black enameled angled cap
- Stainless steel two-piece easy to assemble backguard and plate shelf
- Range mounted salamander broiler (model SER-686).
- Marine equipment - storm rails, oven door latch, drip tray stop and deck fasteners

### Specifications

Electric medium-duty range with a full-size oven.

All porcelain oven interior.

Contoured front stainless steel plate rail.

36" (914mm) wide, with 6 all purpose sealed high-performance heating elements.

Stainless steel exterior, with stainless steel 10" (254mm) high backguard with slotted black enameled angled cap.

Overheat protection reduces power if element is turned on w/o pan for 8 minutes

Optional hot top(s) and griddle. Maximum of 2 hot top sections on any S686/SS686 model.

Available with convection oven base.

NOTE: Use only Garland certified casters and approved restraining devices.



SS686 Sentry Series Electric Restaurant Range

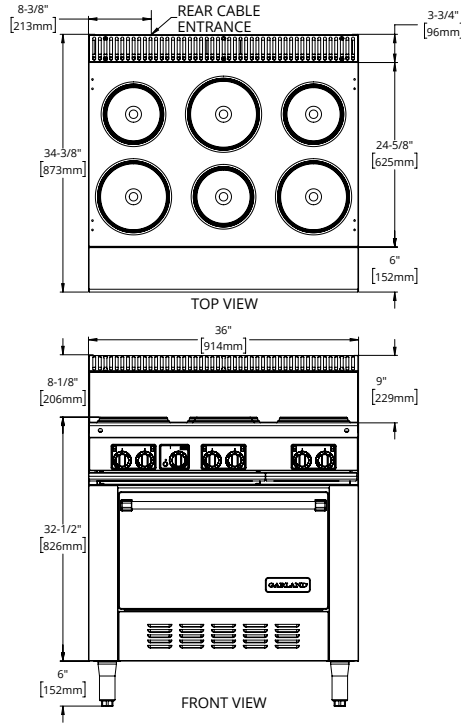

This product is not approved for residential use. Many local codes exist and it is the responsibility of the owner and installer to comply with those codes.

Note: Installation clearance reductions are applicable only where local codes permit.

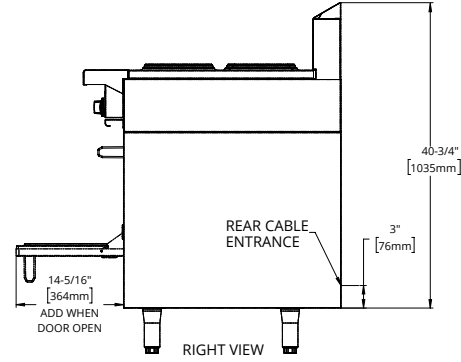

Model #	Total kW Load	Nominal Amps						
		208V/1Ph	208V/3Ph	240V/1Ph	240V/3Ph	380V/3N	400V/3N	415V/3N
SS686	19****	90	59	78	52	39	40	38
SS686RC*	20****	93	62	80	54	39	40	38
S686 Griddle / Hot Top Only**	15	72	48	62	42	29.2	29.2	28
S686RC Griddle / Hot Top Only**	16	75	51	64	44	30	30	28
Salamander Broiler***	7	N/A	23	29	20	15.2	15.2	14.6

\*Maximum on any 686 series range.

\*\*Contact factory for specific configurations.

\*\*\*Add when wired to range base (SER-686). Note: For 208V/1Ph the salamander cannot be wired into the range.

\*\*\*\* Total kW load for 380/3N model is 18 kW.

Exterior Dimensions			Oven Interior Dimensions		
Height	Width	Depth†	Height	Width	Depth
47" (1194mm)	36" (914mm)	34-1/4" (870mm)††	13-1/2" (343mm)	26-1/4" (667mm)	22" (559mm)

† With Front Rail Note: Shipping Cubic Feet is 58.5.

†† Convection Ovens Add 4-3/4" (121mm) to Depth.

**Ratings:**

- Sealed Elements - Small 7-1/2" (191mm), 2000 Watts. Large 9" (229mm), 2600 Watts
- Hot Plate - (per 12"/305mm section) - front and rear sections each 1675 Watts, (3350 Watts total)
- Griddle - (per 12"/305mm section) - 3350 Watts
- Standard Oven - 4.85 kW
- Convection Oven - 5.0 kW (plus 0.5kW fan motor, for 5.5kW total)

**NOTE:** Many local codes exist, and it is the responsibility of the Owner and the Installer to comply with those codes.

Installation Clearances	Side	Back
Range w/o salamander	3" (76mm)	2" (51mm)
Range w/ salamander	7" (178mm)	2" (51mm)
Hot Plate	10" (254mm)	—

NOTE: For ranges with convection oven(s), (models with suffix -RC), air circulation is required for proper operation of fan motors. These models must not be dais mounted or installed without legs/casters.

Garland reserves the right to make changes to the design or specifications without prior notice.

Garland Commercial Ranges Ltd.  
1177 Kamato Road,  
Mississauga, Ontario  
L4W 1X4 CANADA

General Inquires 1-905-624-0260  
USA Sales, Parts and Service 1-800-424-2411  
Canadian Sales 1-888-442-7526  
Canada or USA Parts/Service 1-800-427-6668

www.garland-group.com  
8140B  
05/26

