

# BASE UNDERCOUNTER REFRIGERATOR

## Model: RA118N-U

Natural Refrigerant R-290 Model

### 118" Base Undercounter Refrigerator with Solid Doors

Heavy gauge #300 Series stainless steel top, stainless steel front and end panels, galvanized steel rear and grill and aluminum interior.



## Options and Accessories

(upcharge and lead times may apply)

Stainless steel interior	Door locks
Stainless steel back	Compressor left (standard on right)
Additional epoxy coated steel shelves	Drawers in lieu of doors**
Stainless steel shelves	Drawer in lieu of door section above the condensing unit*
Pan slides	

Consult factory for other model configurations, options and accessories.

\*Drawer section above condensing unit holds (1) 12 x 20 x 6 pan.

\*\*Two tier (larger section): (2) 12x20x6 pans per drawer

**Continental**  
Refrigerator



Project Name:

Model Specified:

Location:

Item No:

Quantity:

AIA #:

SIS #:

## Standard Model Features

### REFRIGERATION SYSTEM

Performance rated refrigeration system

Natural, environmentally safe, high efficiency R-290 refrigerant<sup>1</sup>

Unique forced air design utilizes fans (approx. every 12") across the entire back of unit for even distribution of cold

Automatic, hot gas condensate evaporator

Non-corrosive, plasticized fin evaporator coil

Easily serviceable, slide out condensing unit

Expansion valve system

### CABINET ARCHITECTURE

2" non-CFC polyurethane foam insulation

Smooth, polished chrome door handles

Spring loaded, self closing doors

Magnetic snap in Santoprene™ door gaskets

Heavy duty, epoxy coated steel shelves

Completely enclosed, vented and removable rear and side grills

(12) 1 3/8" diameter plate casters mounted on heavy duty support plates (easily field installed)

### MODEL FEATURES

Electronic control, off cycle defrost

Front breather air divider (field installed)

Reversing condenser fan motor (runs for short period during startup to clear any debris)

Refrigerated section with door above the condensing unit

Field rehingeable doors

<sup>1</sup> R-290 refrigerant meets all federal and state regulatory requirements.

**NOTE:** Models come standard with a door over the condensing unit. A drawer over the condensing unit is an option.

APPROVAL:

# Model Specifications

## DIMENSIONAL DATA

Net Capacity (cubic feet)	44 (1246 l)
Width, Overall (inches)	118 (2997 mm)
Depth, Overall (inches) (including handles & bumpers)	37 (939 mm)
Height, Overall (inches) (including 1 3/8" plate casters)	31 3/4 (806 mm)
Shelf Area (square feet)	18.4 (1.7 sq m)
Number of Shelves	8
Number of Full Doors	4
Number of Half Doors	1
Interior Depth (inches)	30 (762 mm)
Interior Height (inches)	26 (660 mm)
Interior Height (inches) (above condenser)	12 1/2 (318 mm)
Interior Width (inches)	114 (2896 mm)

## REFRIGERANT DATA

Condensing Unit Size (H.P.)	1/4
R-290 Refrigerant Charge (oz)	5.0
Capacity (BTU per hour)*	1930

## ELECTRICAL DATA

Voltage (International)	115/60/1 (220/50/1)
Total Amps (International)	3.1 (1.6)
10 ft. Cord/Plug [attached] (International)	Yes (No)

## SHIPPING DATA

Weight (pounds)	880 (400 kg)
Height - Crated (inches)	45 (1111 mm)
Width - Crated (inches)	127 (3048 mm)
Depth - Crated (inches)	39 (1194 mm)

\* Rating @ +25°F evaporator, 90°F ambient  
Figures in parentheses reflect metric equivalents rounded to the nearest whole unit.

# Model Plan Views

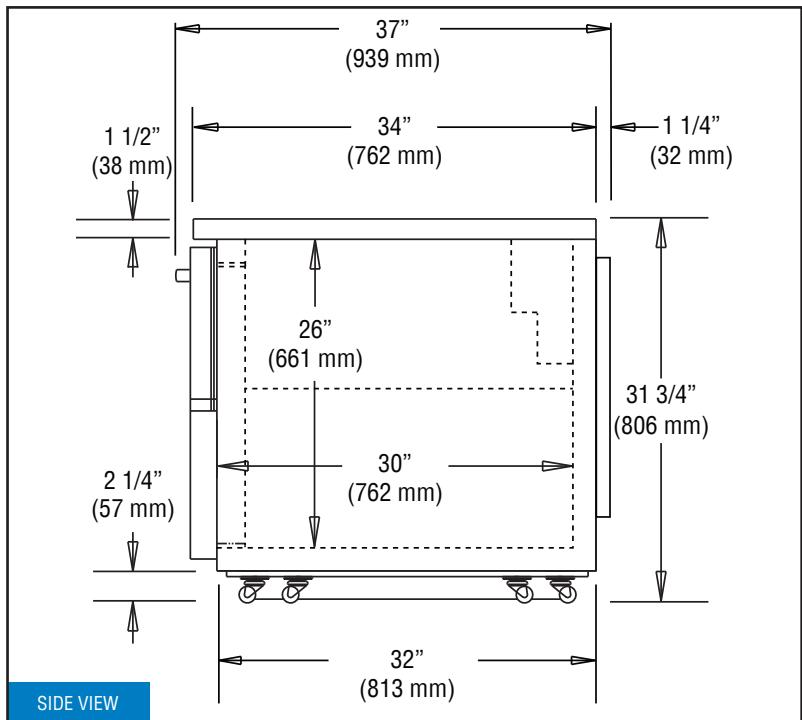
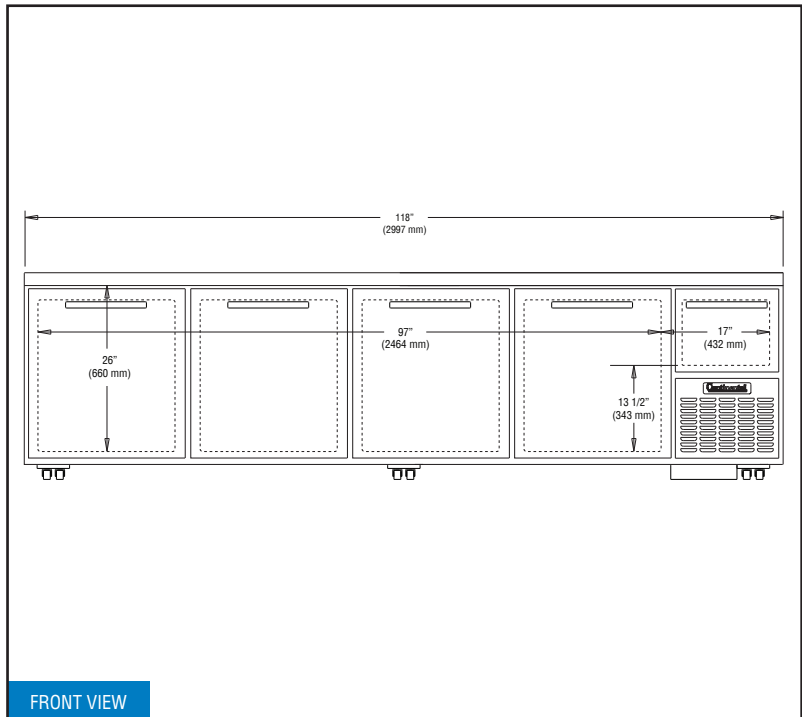

**NOTE:** For proper operation, the area under and in front of the cabinet **must** not be obstructed in any way.



Toll-Free: 800-523-7138  
Phone: 215-244-1400  
Fax: 215-244-9579

539 Dunksferry Road  
Bensalem, PA 19020  
www.continentalrefrigerator.com

Due to our continued efforts in developing innovative products, specifications subject to change without notice.



PROUDLY  
DESIGNED & ASSEMBLED  
IN THE U.S.A.



Equipped with one NEMA-5-15P Plug  
(varies by country)