

Mobile Beverage Cooler

Standard Features

INTERIOR LINER: 18 gauge stainless steel fully welded liner with breaker strip attachment to exterior panels.

EXTERIOR: 20 gauge stainless steel.

DOORS: 20 gauge double pan insulated sliding door.

INSULATION: High pressure foamed in place 2" thick polyurethane.

CASTERS: Heavy duty 5" diameter plate casters with gray rubber tires. Brake models to be supplied on all casters.

DRAIN: 1/2" stainless steel nipple fully welded to interior liner with brass gate valve at exterior.

CONDENSING UNIT: R-404A high temperature hermetically sealed with expansion valve and pressure switch operation.

CONDENSING UNIT HOUSING: Front and rear removable louver panels for flow through air design.

CORNER BUMPERS: Rubber bumpers provided on each corner.

THERMOMETER: 2 1/2" dial thermometer.

STAINLESS STEEL SPECIFICATION: All stainless steel to be type 304 with number 4 finish except door contact cap which will be magnetic type 430 stainless steel.

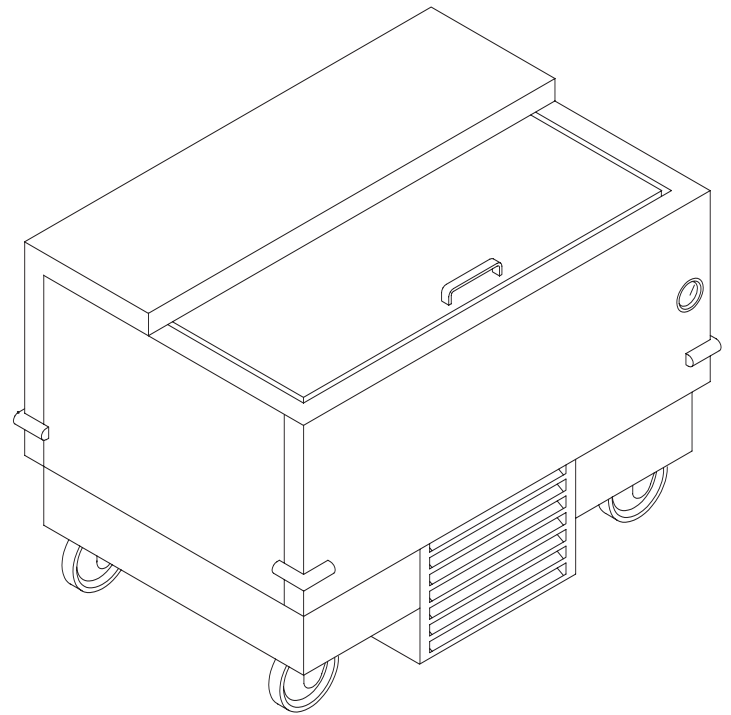

MODEL	LENGTH	WIDTH	HP	VOLTS	PHASE	AMPS	NEMA CORD/CAP	APPROX. SHIP WEIGHT
MCT-BC1S	42"	30.5"	1/4	120	1	8.0	NEMA 5-15P	390 lbs



2320 Peyton Houston, Texas 77032
 Phone 281-442-8001 Toll Free: 888-955-5463 Fax: 281-442-3351 www.mod-u-serve.com

Mobile Beverage Cooler

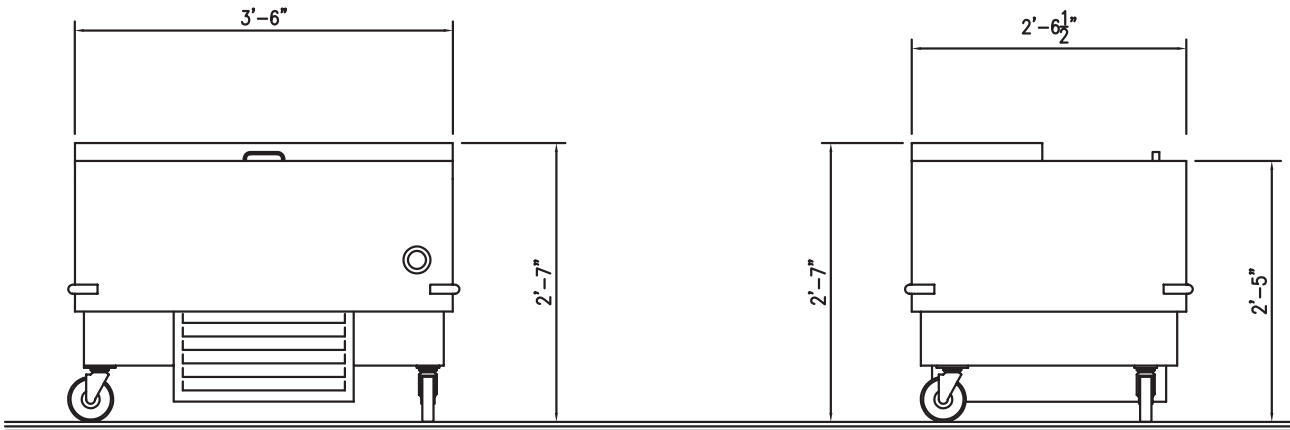

Optional Features

LEGS: 6" adjustable stainless steel legs in lieu of casters.

ADDITIONAL WARRANTY: Additional 12 month limited warranty on parts and labor.

For options / accessories / modifications not shown, please contact factory.



Mod-U-Serve reserves the right to modify specifications or discontinue models without notice or incurring obligation.



2320 Peyton Houston, Texas 77032

Phone 281-442-8001 Toll Free: 888-955-5463 Fax: 281-442-3351 www.mod-u-serve.com