



Job \_\_\_\_\_ Item No. \_\_\_\_\_

# Star® QCS1 Series Conveyor Toasters

☐QCS1-350 ☐QCS1-500



QCS1-350

## DESCRIPTION

Compact conveyor toasters require only 14-1/4" of counter space and are constructed of corrosion resistant stainless steel. 1-1/2" product opening. Forced convection system keeps the toaster cool- to-the-touch and extends the life of critical components. Extended conveyor belt, crumb tray, heated holding area and full width burn guard are standard. Heavy-duty motor, drive chain and conveyor speed control for superior reliability. Toast bread, bagels, English muffins and more!

## SPECIFICATIONS

Toasters are built with stainless steel construction for long lasting durability. Heavy-duty motor, drive chain and conveyor speed control for superior reliability. Conveyor belt tension system for smooth and quiet operation. High performance Quartz Infrared Heaters for superior toasting performance and reliability. Units are easy to disassemble with one-piece cover for cleaning and service. Toasters are furnished with 1" adjustable legs and 4' cord and a standard NEMA 5-15 plug for plug in installation in a grounded 120V outlet.

## WARRANTY

These units come with a one [1] year warranty for parts and labor.

## FEATURES

- Forced convection system keeps the toaster cool-to-the-touch and increases productivity by circulating pre-heated air into toasting chamber
- 10" wide belt for up to 2-slices of bread, side-by-side
- Quartz infrared heaters provide faster, more consistent heating than traditional heating elements
- Long lasting, heavy-duty metal knobs and 1" non-skid heavy-duty rubber feet
- Easy-to-use analog controls
- Power saver switch that reduces electricity consumption by 75%
- Extended conveyor belt for easy loading and large warming area for higher production
- Safe load-up area with full width coated front burn guard and cool-to-the-touch exterior
- Heated holding area to keep toast at the perfect temperature
- Hi-limit switch prevents toaster from overheating protecting critical component parts
- Variable speed and top/bottom heat control for perfect color and texture of bread, bagels, English muffins and more
- 120V - plugs in anywhere

TOASTING CAPACITY		
MODEL	DESCRIPTION	SLICES PER HOUR
QCS1-350	1.5" Opening COMPACT TOASTER	350
QCS1-500	1.5" Opening BAGEL TOASTER	500

## CERTIFICATIONS



### STAR MANUFACTURING INTERNATIONAL INC.

265 Hobson St. Smithville, TN 37166

Telephone 800-264-7827

www.star-mfg.com

Printed in the U.S.A. • 2M-Z22825 REV B (11-24)

Please refer to the owner's manual for information regarding installation or use.



# Star® QCS1 Series Conveyor Toasters

□QCS1-350 □QCS1-500

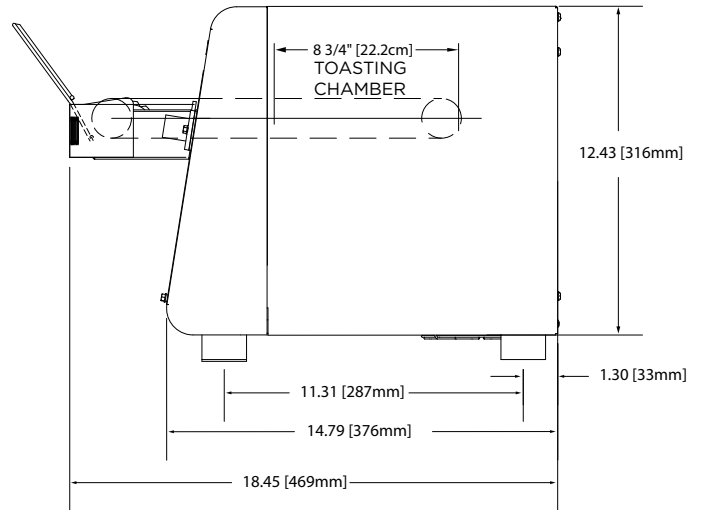
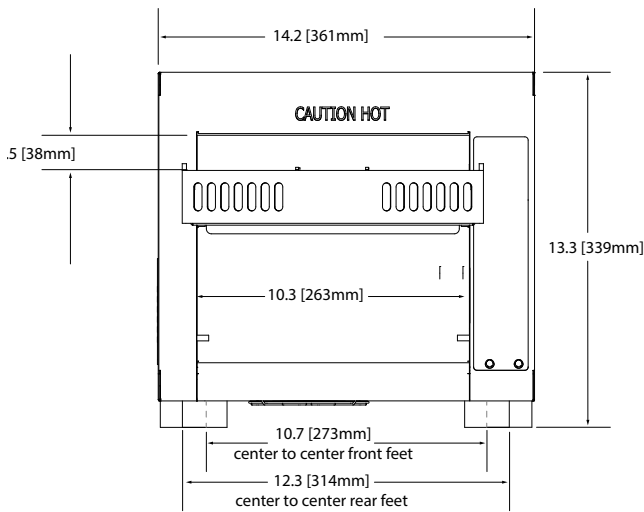

MODEL	DESCRIPTION	SLICES PER HOUR	HEIGHT in. (mm)	WIDTH in. (mm)	DEPTH in. (mm)	VOLTS <sup>1</sup>	HZ 1-PH	AMPS	WATTS	NEMA PLUG	APPROX. SHIP WEIGHT
QCS1-350	1.5" Opening COMPACT TOASTER	350	15.63 (397.0)	13.25 (336.6)	18.88 (479.6)	120 120 (CSA) 230	60 60 50	13.3 11.7 7.0	1,600 1,400 (CSA) 1,600	5-15P 5-15P (CSA) CEE7/7	44 lb. (20 kg)
QCS1-500	1.5" Opening BAGEL TOASTER	500	15.63 (397.0)	13.25 (336.6)	18.88 (479.6)	120 120 (CSA) 230	60 60 50	13.3 11.7 7.0	1,600 1,400 (CSA) 1,600	5-15P 5-15P (CSA) CEE7/7	44 lb. (20 kg)

<sup>1</sup>Specify 120V, 230V service and Canadian applications when ordering.  
230V Options Available for all QCS1 models.



5-15P



CEE7/7

Due to periodic changes in designs, methods, procedures, policies and regulations, the specifications contained in this sheet are subject to change without notice. While Star Manufacturing exercises good faith efforts to provide information that is accurate, we are not responsible for errors or omissions in information provided or conclusions reached as a result of using the specifications. By using the information provided, the user assumes all risks in connection with such use.



## STAR MANUFACTURING INTERNATIONAL INC.

265 Hobson St. Smithville, TN 37166

Telephone 800-264-7827

www.star-mfg.com

Printed in the U.S.A. • 2M-Z22825 REV B (11-24)

Please refer to the owner's manual for information regarding installation or use.