



**Take your bake anywhere! New Optional Ventless Internal Catalyst Design.**

**CONVECTION OVEN  
PLATINUM SERIES  
BAKERY, ELECTRIC, DOUBLE DECK**



PCE15B/S shown with optional casters

STANDARD TOUCHSCREEN

- PCE15B/S
- PCE22B/S
- PCE15B/T
- PCE22B/T

**Standard Features**

- 7.5kW or 11kW high efficiency heating elements per deck
- Double deck convection oven is 64.8" in height
- Standard or Digital Touchscreen Controls with manual, recipe, or rack modes.
- Patented "plug-in, plug-out" control panel - easy to service
- Slide out control panel for full view servicing
- Stainless Steel front, sides and top
- Dependent glass doors (Full 180° opening)
- Energy saving high efficiency glass windows
- Heat keeping dual door seal system
- Coved, fastener-free, porcelain enamel finish interior
- Stay cool heavy duty door handle
- Two speed, 1/2 hp, fan motor
- 11-position rack guides and 5 plated oven racks
- Forced cool down fan mode
- Interior oven lights
- (1) year limited parts and labor warranty (reference <https://southbendnc.com/service-and-parts> for limited warranty details)

**Available Controls**

**SC-Standard Controls**

140°F to 500°F solid state thermostat and 60 minute mechanical cook timer.

**TC-Touchscreen Controls**

150°F to 550°F temperature controller with 140°F to 200°F "Hold" thermostat. Digital display shows time and temperature. A fan cycle timer pulses the fan. Recipes can be created and used in oven group 'Rack' mode to cook multiple items at once on different timers.

**OPTIONS & ACCESSORIES AT ADDITIONAL COST**

- Ventless Design \*(UL certified)
- List the voltage, frequency, and amps (see utility information).  
\_\_\_ VAC, \_\_\_ Phase, \_\_\_ Hz
- Independent doors
- Stainless steel exterior bottom
- Casters 4" or 6"
- Marine edge top
- 2" air insulation panel (stainless steel only)
- Down draft diverter for direct flue
- Export crating
- Stainless steel dirt tray
- Stainless steel solid doors
- Stainless steel rear jacket

**STANDARD CONSTRUCTION SPECIFICATIONS**

**Exterior Finish:** Stainless steel front, top and sides.  
**Doors:** Dependent doors with windows. Low emission glass, stainless steel construction, heavy-duty welded steel frame and 5/8" diameter full-length hinge pin.  
**Oven Interior:** Porcelain enamel finish, coved, fastener free.  
**Rack and Rack Guides:** Heavy-duty removable wire rack guides spaced on 1-5/8" centers offer 11 different rack positions. 5 wire racks provided with each oven.  
**Blower Fan and Motor:** 1/2hp, 2-speed motor, 1710/1120  
**Oven Heating:** Oven heating is regulated by an adjustable solid state thermostat control. Blower fan circulates air within the cavity "scrubbing" heat to the oven interior for even heat distribution within the cavity. Manual

reset high limit temperature control protects the oven from overheat condition.  
**Control Panel:** Located on front, at right side of oven, away from heat zone. Slide out panel extends over 17" for easy servicing.  
**Interior Lights:** Two 40 watt high temperature recessed lamps located within the oven cavity.  
**Legs:** 6" stainless steel legs standard.  
**Electrical System:** The sheath type electrical heating elements located at the rear of the oven function as a single heating unit with a combined rating of 7.5 kW or 11kW per deck. Available voltages include 208, 240, 380, and 480 VAC single or three phase, 50/60 Hz. Ovens equipped with 480VAC single or three phase heating elements use 240V controls and motors and do not require separate electrical lead wires.



Approval Notes: \_\_\_\_\_

PCEB-DOUBLE

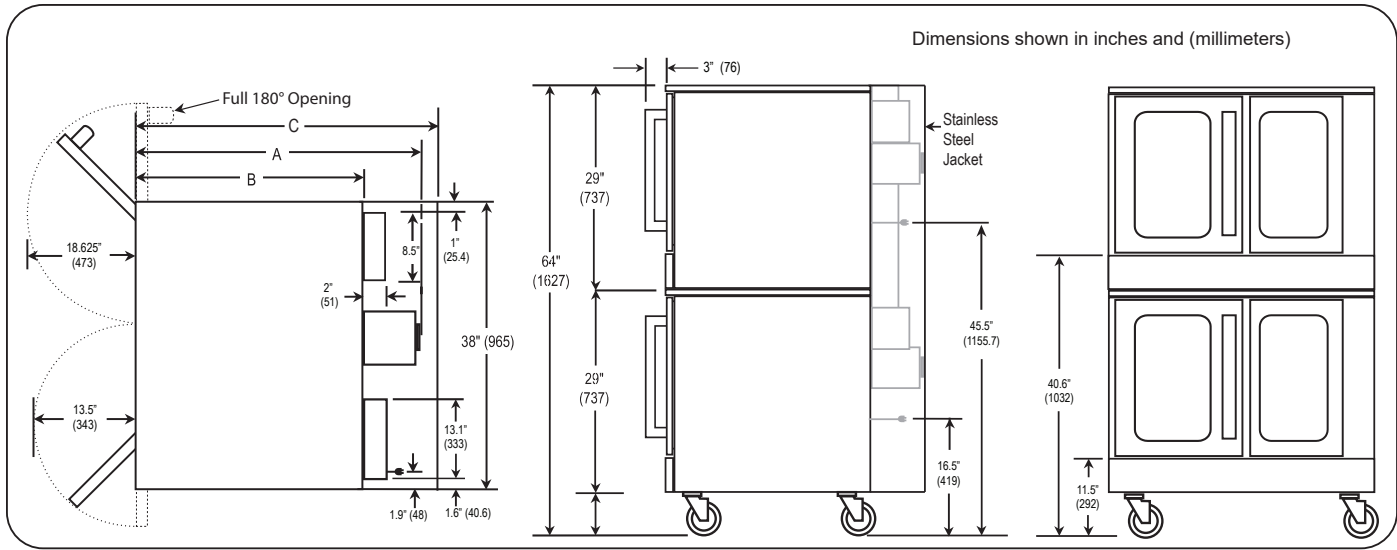

### DIMENSIONS

| MODEL  | DEPTH            |                 |                  | OVEN INTERIOR |              |              | RACK CLEARANCE  |                 | SHIPPING CRATE   |                 |                 |                                |                         |
|--|------------------|-----------------|------------------|---------------|--------------|--------------|-----------------|-----------------|------------------|-----------------|-----------------|--------------------------------|-------------------------|
|  | A                | B               | C                | WIDTH         | DEPTH        | HEIGHT       | WIDTH           | DEPTH           | WIDTH            | DEPTH           | HEIGHT          | VOLUME                         | WEIGHT                  |
| PCE15B/S<br>PCE22B/S<br>PCE15B/T<br>PCE22B/T | 43.50"<br>(1146) | 36.50"<br>(924) | 45.75"<br>(1162) | 29"<br>(737)  | 29"<br>(737) | 20"<br>(508) | 28.25"<br>(718) | 27.25"<br>(692) | 57.50"<br>(1461) | 45.5"<br>(1156) | 81.5"<br>(2070) | 123.4 cu. ft.<br>(3.49 cu. m.) | 1180 lbs<br>(535.2 kg.) |

Dimensions shown in inches and (millimeters)

### UTILITY INFORMATION

**Standard:** 1/2 horsepower, 2 speed motor, 1710/1120 r. p. m.

| ELECTRICAL DATA            |                   | AMPS PER LINE |         |      |      |       |
|----------------------------|-------------------|---------------|---------|------|------|-------|
| EACH OVEN                  | VOLTAGE           | 1 PHASE       | 3 PHASE |      |      |       |
|                            |                   |               | X       | Y    | Z    | NEUT. |
| 11kW for Heating Elements  | 208 VAC, 60HZ     | 52.9          | 30.6    | 30.6 | 30.6 | 0     |
|                            | 220/240 VAC, 50HZ | 42.1          | 24.3    | 24.3 | 24.3 | 0     |
|                            | 240 VAC, 60HZ     | 45.9          | 26.5    | 26.5 | 26.5 | 0     |
|                            | 380/220 VAC, 50HZ | 29            | 16.8    | 16.8 | 16.8 | 0     |
|                            | 415/240 VAC, 50HZ | 45.9          | 15.4    | 15.4 | 15.4 | 0     |
|                            | 480 VAC, 60HZ     | 23            | 13.3    | 13.3 | 13.3 | 0     |
| 7.5kW for Heating Elements | 208 VAC, 60HZ     | 36.1          | 20.9    | 20.9 | 20.9 | 0     |
|                            | 220/240 VAC, 50HZ | 28.7          | 16.6    | 16.6 | 16.6 | 0     |
|                            | 240 VAC, 60HZ     | 31.3          | 18.1    | 18.1 | 18.1 | 0     |
|                            | 380/220 VAC, 50HZ | 19.8          | 11.4    | 11.4 | 11.4 | 0     |
|                            | 415/240 VAC, 50HZ | 31.3(X-Neut.) | 10.5    | 10.5 | 10.5 | 0     |
|                            | 480 VAC, 60HZ     | 15.7          | 9.1     | 9.1  | 9.1  | 0     |

*\* Electric units available for single or three phase operation and must be specified upon ordering. Add up to 4.3 amps for the control panel. Controls are single phase (lineX and lineZ on Delta - 208,240,480), (lineZ and Neut. on 380, 415).*

### MISCELLANEOUS

- Clearances from combustibles:  
Front and right side: 0", back and left side 2".
- Recommended - install under vented hood. Hood not required for ventless option.
- Check local codes for fire and sanitary regulations.

**NOTICE:**

Southbend has a policy of continuous product research and improvement. We reserve the right to change specifications and product design without notice. Such revisions do not entitle the buyer to corresponding changes, improvements, additions or replacements for previously purchased equipment.

**INTENDED FOR COMMERCIAL USE ONLY.  
NOT FOR HOUSEHOLD USE.**

