

**REFRIGERATOR MANUFACTURER**  
**Turbo air**  
 more durable, efficient, beautiful

4184 E. Conant St.  
 Long Beach, CA 90808  
 Tel. 310-900-1000  
 Fax. 310-900-1077  
[www.turboairinc.com](http://www.turboairinc.com)

Project:	
Model #:	
Item #:	
Available W/H:	Qty:
Approval:	
AIA #:	SIS #:
CSI Section 11400	

## Worktop Freezer

Worktops  
 Super Deluxe Series

### Patented Self-Cleaning Condenser

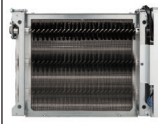

This product is equipped with a fine mesh filter to the front of the condenser to catch dust, and a rotating brush that moves up and down daily to remove excess buildup outward and away.

**Model : TWF-48SD-N**



### ≡ FEATURES & BENEFITS ≡

#### ■ Self-Cleaning Condenser

The accumulation of dust in the condenser can cause the failure or breakdown of refrigerators. Refrigerators run normally until they reach a certain level of accumulation. At some point, when they are over the limit, their performance drops quickly resulting in damage to, or disposal of the stored products inside. The Self-Cleaning Condenser device keeps the condenser clean and prevents system failure by automatically brushing daily.

#### ■ Digital temperature control & monitor system

Keeps food products safe by maintaining constant temperatures. External digital display allows for easy monitoring.

#### ■ Hydrocarbon refrigerants (R-290)

With innovative and eco-friendly technology, Turbo Air brings you hydrocarbon refrigerators designed to meet DOE's Energy Conservation Standards in 2017 and to use EPA's SNAP Program approved HC refrigerants. Hydrocarbon refrigerants do not deplete the ozone layer and have very low contribution to global warming (ODP-0, GWP-3).

#### ■ Stainless steel cabinet construction

The Turbo Air Super Deluxe model boasts a stainless steel interior and exterior (galvanized steel back & bottom). It guarantees the utmost in cleanliness and long product life. The Super Deluxe adds a touch of style to the most refined setting.

#### ■ Sturdy, clean stainless steel shelving

Shelves are the most important part of cleanliness as they come in direct contact with food. After a while, PVC coated wire shelves may peel, rust and lead to unsanitary conditions. Only the Turbo Air Super Deluxe series uniquely provides stainless steel shelving.

#### ■ Ergonomically designed doors

Customers' fatigue fades away with easy grip handles and doors that open effortlessly. These features along with self-closing doors make this the ultimate choice in customer convenience. ABS sheet door liners resist water condensation with thermal efficiency.

#### ■ High-density polyurethane insulation

The entire cabinet structure and solid doors are foamed-in-place using high density, CFC free polyurethane insulation.

#### ■ Magnetic door gaskets

Magnetic door gaskets are of one-piece construction, removable without tools for ease of cleaning and replacement.

#### ■ LED interior lighting & fan control

#### ■ Freezer holds -10°F ~ 0°F for the best in frozen food preservation

NATURAL  
 Refrigerant



Model	Swing Doors	CU./FT.	#of Shelves	HP	AMPS	Crated Weight (lbs.)	L x D x H <sup>†</sup> (inches)
TWF-48SD-N	2	12	2	1/3	2.8	258	48 1/4 x 30 x 33 5/8

## Model : TWF-48SD-N

ELECTRICAL DATA	
Voltage	115/60/1
Plug Type	 NEMA 5-15P
Full Load Amperes	2.8
Compressor HP	1/3
Cord Length (ft.)	9
Refrigerant	R-290
DIMENSIONAL DATA	
Net Capacity (cu. ft.)	12
Ext. Length Overall (in.)	48 1/4 (1225mm)
Ext. Depth Overall (in.)*	30 (762mm)
Ext. Height Overall (in.) †	33 5/8 (853mm)
# of Doors	2
# of Shelves	2
Shelf Size (L x D) (in.)	21 x 17
Net Weight (lbs.)	235
Gross Weight (lbs.)	258

Design and specifications subject to change without notice.  
Actual shipping weight may differ due to extra packing materials for product protection.  
\* Depth does not include 1" for rear spacers.  
† Height does not include 5-5/8" for caster height.

- **WARRANTY : 5 Year Parts and Labor Warranty  
7 Year Compressor Warranty**

### STANDARD FEATURES

- *Anti-corrosion coated evaporator*
- *Self-contained system*
- *4" dia. swivel casters with locks on the front set*
- *Door locks*

### OPTIONAL ACCESSORIES

- 1" caster, 1/2" diameter & 13 TPI: S28R813660 (non-brake)
- 2.5" caster, 1/2" diameter & 13 TPI: 30265H0100 (non-brake), 30265H0200 (w/ brake)
- 5" caster, 1/2" diameter & 13 TPI: M726500100 (non-brake), M726500200 (w/ brake)
- Leveling leg, 1/2" - 13 TPI x 1.54": LFM1213566
- 6" ABS plastic leg: 30221M0200
- 6" stainless steel leg: 30221M0600
- Single overshelf, stainless steel, 48-3/8" W: TSOS-4SW
- Double overshelf, stainless steel, 48-3/8" W: TSOS-4R-V

## PLAN VIEW

(unit : inch)

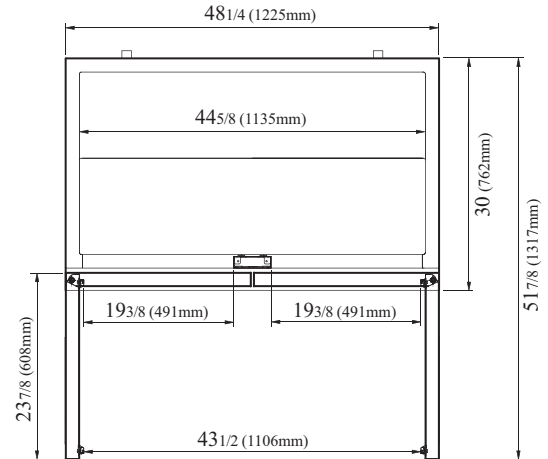

TOP VIEW

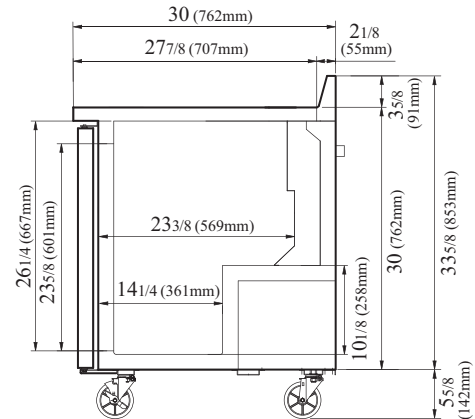

SIDE VIEW

Ver.20260515



- Turbo Air: 800-627-0032
- Bake Tech Innovation: 800-500-3519
- Warranty: 800-381-7770
- AC: 888-900-1002