

Drop-In Drop-in bain-marie, with four wells (4 GN container capacity)

ITEM # _____

MODEL # _____

NAME # _____

SIS # _____

AIA # _____

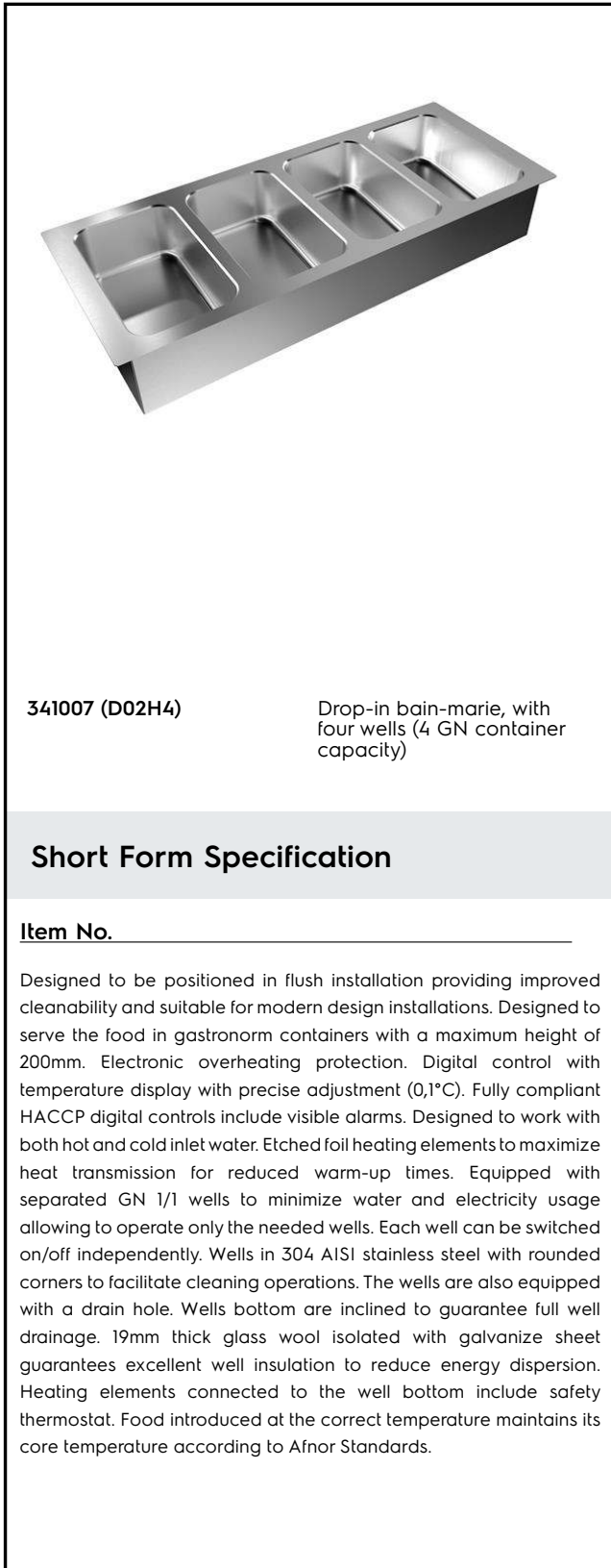
341007 (D02H4)

Drop-in bain-marie, with four wells (4 GN container capacity)

Short Form Specification

Item No. _____

Designed to be positioned in flush installation providing improved cleanability and suitable for modern design installations. Designed to serve the food in gastronorm containers with a maximum height of 200mm. Electronic overheating protection. Digital control with temperature display with precise adjustment (0,1°C). Fully compliant HACCP digital controls include visible alarms. Designed to work with both hot and cold inlet water. Etched foil heating elements to maximize heat transmission for reduced warm-up times. Equipped with separated GN 1/1 wells to minimize water and electricity usage allowing to operate only the needed wells. Each well can be switched on/off independently. Wells in 304 AISI stainless steel with rounded corners to facilitate cleaning operations. The wells are also equipped with a drain hole. Wells bottom are inclined to guarantee full well drainage. 19mm thick glass wool isolated with galvanize sheet guarantees excellent well insulation to reduce energy dispersion. Heating elements connected to the well bottom include safety thermostat. Food introduced at the correct temperature maintains its core temperature according to Afnor Standards.

Main Features

- Electronic overheating protection.
- Designed to serve the food in gastronorm containers.
- Suitable for GN 1/1 containers with a maximum height of 200 mm.
- Precise temperature control and setting at 0,1°C .
- As standard the product comes with digitally controlled thermostat which is in line of HACCP norms and provides visual alarm as a warning of the increasing or decreasing temperatures.
- Etched foil heating elements to maximize heat transmission for reduced warm-up times.
- It is possible to transform one of the GNs to soup dispenser with the available accessory.
- Equipped with separated GN 1/1 wells to minimize water and electricity usage allowing to operate only the needed wells. Each well can be switched on/off independently.
- CB and CE certified by a third party notified body.
- Designed to be positioned in flush installation providing improved cleanability and suitable for modern design installations.
- Available drop-in dimensions: 2, 3, 4 GN.
- Food introduced at the correct temperature maintains its core temperature according to Afnor Standards.
- Designed to work with both hot and cold water.

Construction

- Heating elements connected to the well bottom include safety thermostat.
- IPx4 water protection.
- Electronic control with temperature display.
- 19mm thick rock wool isolated with galvanize sheet guarantees excellent well insulation to reduce energy dispersion.
- Well in 304 AISI stainless steel with rounded corners to facilitate cleaning operations. The well is also equipped with a drain hole.
- Wells bottom are inclined to guarantee full well drainage.

APPROVAL: _____

Drop-in bain-marie, with four wells (4 GN container capacity)

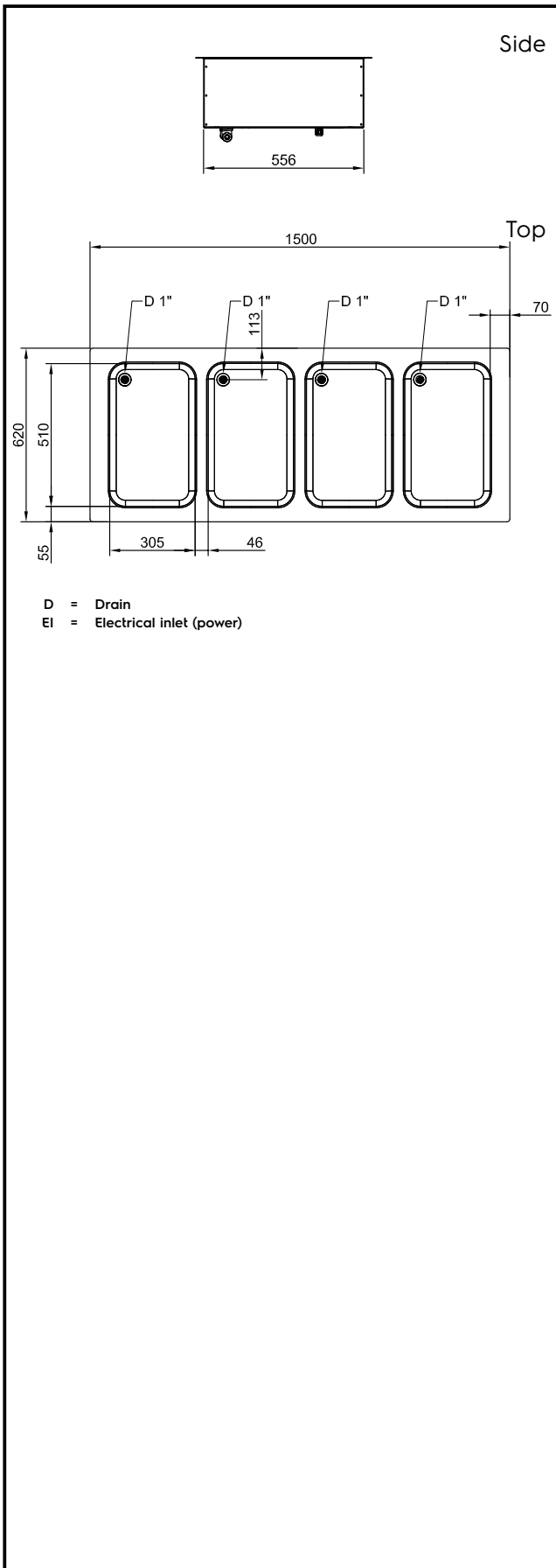

Electric

Supply voltage:

341007 (D02H4) 380-410 V/3N ph/50/60 Hz

Electrical power max.:

4.02 kW

Water:

Drain line size:

1"

Key Information:

External dimensions, Width: 1500 mm

External dimensions, Height: 260 mm

External dimensions, Depth: 620 mm

Net weight: 39.3 kg

Shipping weight: 59.3 kg

Shipping height: 380 mm

Shipping width: 1540 mm

Shipping depth: 660 mm

Shipping volume: 0.39 m³

Set temperature: +90 / +100 °C

Noise level: 0 dBA

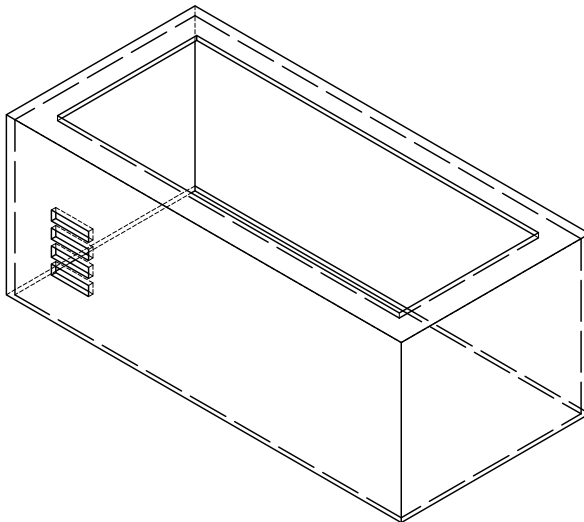
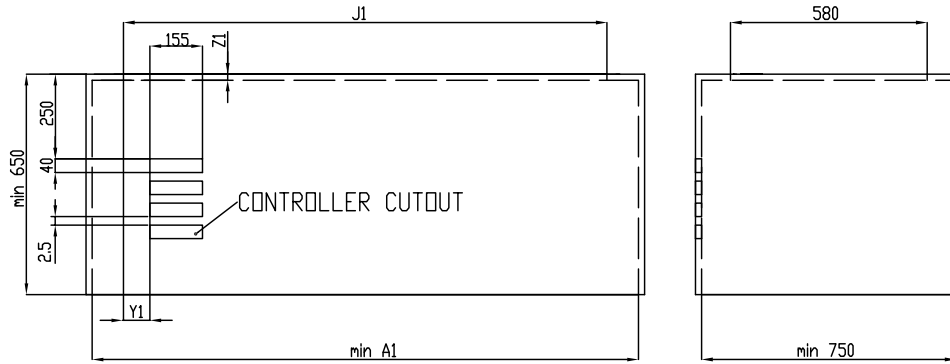

	J1	A1	Y1	Z1
2 GN	730	910		
3 GN	1080	1260	80	20
4 GN	1430	1610		

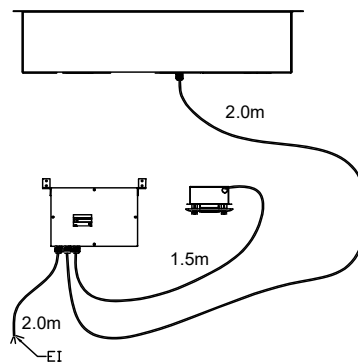
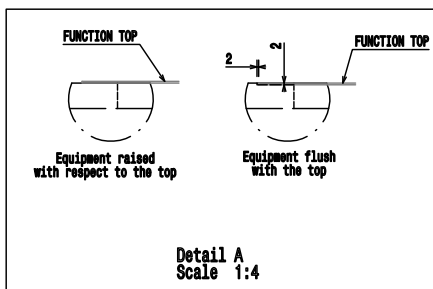

2. IDS WATER BAIN MARIE SEPARATED WELLS