

"ST6R5-GSK" STAINLESS STEEL TOP WORK TABLES

16GA Top w/5" Riser & Galvanized Legs & Adjustable Undershef

FEATURES:

- 16GA Stainless Steel Top w/5" Riser & Turndown
- Type 300 Stainless Steel With #4 Polish, Satin Finish
- Top Is Sound Deadened
- Reinforced With 1"x2" Channel Running Entire Length Of Table
- 1-1/2" Stallion Edge On Front Side Edges 90 Degree Bend Down For Table Line-Up
- Galvanized Base With Adjustable Undershef
- Shipped Knocked-Down, Easy-To-Assemble

SPECIFICATIONS:

- Top: Stainless Steel Tops Are TIG Welded, Exposed Welds Are Polished To Match Adjacent Surface
- Top: 16GA Stainless Steel Type 300 Stainless Steel With #4 Polish, Satin Finish
- Shelf: 18GA Galvanized Steel, (36" Wide Tables, 16GA Lower Shelf)
- Legs: 1-5/8" Round O.D. 16GA Tubular Galvanized Steel
- Gussets: Galvanized Steel
- Feet: 1" Adjustable Stainless Steel Bullet Feet



ST6R5-3048GSK

CERTIFICATIONS:



ACCESSORIES

DESCRIPTION

- Drawer
- Drawer Lock
- Casters
- Overshelves
- Sinks
- Pot Rack

"ST6R5-GSK" STAINLESS STEEL TOP WORK TABLES

LENGTH	24" WIDE	WT (LBS)	30" WIDE	WT (LBS)	36" WIDE	WT (LBS)
24"	ST6R5-2424GSK	44	ST6R5-3024GSK	49	ST6R5-3624GSK	58
30"	ST6R5-2430GSK	49	ST6R5-3030GSK	54	ST6R5-3630GSK	68
36"	ST6R5-2436GSK	55	ST6R5-3036GSK	62	ST6R5-3636GSK	75
48"	ST6R5-2448GSK	67	ST6R5-3048GSK	77	ST6R5-3648GSK	93
60"	ST6R5-2460GSK	80	ST6R5-3060GSK	91	ST6R5-3660GSK	111
72"	ST6R5-2472GSK	92	ST6R5-3072GSK	105	ST6R5-3672GSK	129
84"	ST6R5-2484GSK	111	ST6R5-3084GSK	127	ST6R5-3684GSK	159
96"	ST6R5-2496GSK	123	ST6R5-3096GSK	142	ST6R5-3696GSK	177
108"	ST6R5-24108GSK	136	ST6R5-30108GSK	155	ST6R5-36108GSK	193
120"	ST6R5-24120GSK	147	ST6R5-30120GSK	170	ST6R5-36120GSK	211
132"	ST6R5-24132GSK	159	ST6R5-30132GSK	184	ST6R5-36132GSK	228
144"	ST6R5-24144GSK	171	ST6R5-30144GSK	199	ST6R5-36144GSK	246

ALL DIMENSIONS ARE TYPICAL. TOLERANCE +/- .500". JOHN BOOS & CO. RESERVES THE RIGHT TO CHANGE SPECIFICATIONS WITHOUT NOTICE.

DETAILED SPECIFICATIONS

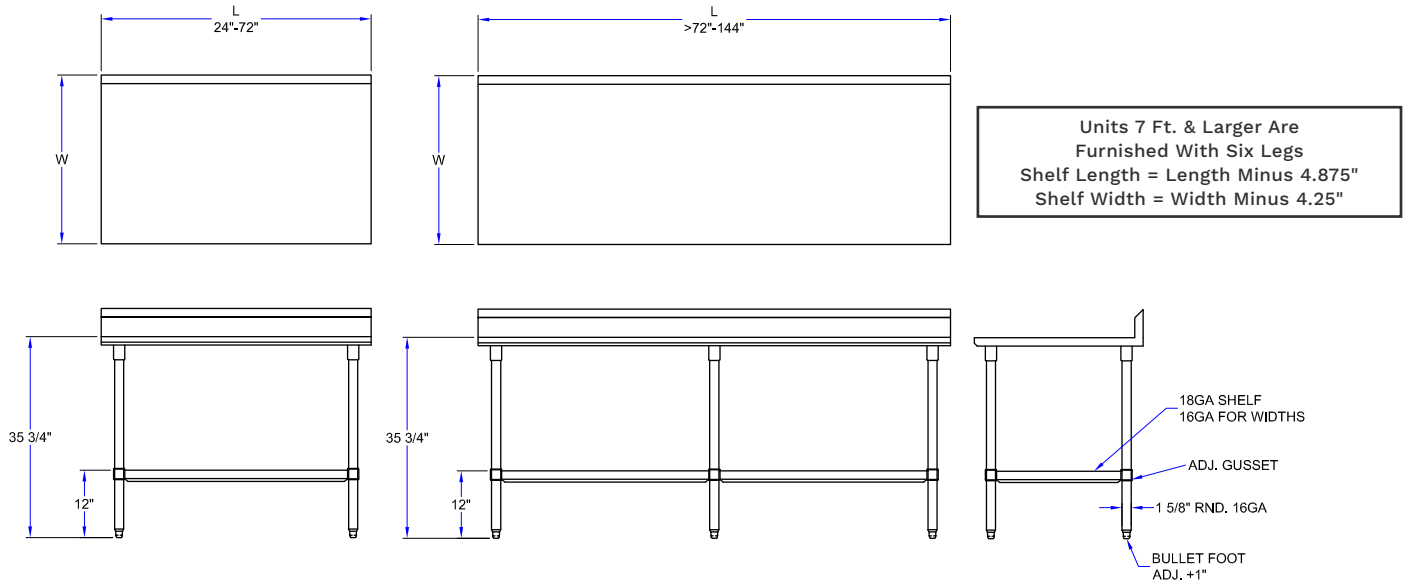

MODEL # STRUCTURE

5 = Ht. Of Riser w/Turndown
R = Top w/Riser
6 = 16GA Work Surface
ST = Stainless Steel Top

24 = Width Of Work Surface
30 = Length Of Work Surface
GS = Galvanized Legs & Shelf
K = Ships Knocked Down

ST6R5-2430GSK

"ST6R5-GSK" STAINLESS STEEL TOP WORK TABLES

LENGTH	24" WIDE	WT (LBS)	30" WIDE	WT (LBS)	36" WIDE	WT (LBS)
24"	ST6R5-2424GSK	44	ST6R5-3024GSK	49	ST6R5-3624GSK	58
30"	ST6R5-2430GSK	49	ST6R5-3030GSK	54	ST6R5-3630GSK	68
36"	ST6R5-2436GSK	55	ST6R5-3036GSK	62	ST6R5-3636GSK	75
48"	ST6R5-2448GSK	67	ST6R5-3048GSK	77	ST6R5-3648GSK	93
60"	ST6R5-2460GSK	80	ST6R5-3060GSK	91	ST6R5-3660GSK	111
72"	ST6R5-2472GSK	92	ST6R5-3072GSK	105	ST6R5-3672GSK	129
84"	ST6R5-2484GSK	111	ST6R5-3084GSK	127	ST6R5-3684GSK	159
96"	ST6R5-2496GSK	123	ST6R5-3096GSK	142	ST6R5-3696GSK	177
108"	ST6R5-24108GSK	136	ST6R5-30108GSK	155	ST6R5-36108GSK	193
120"	ST6R5-24120GSK	147	ST6R5-30120GSK	170	ST6R5-36120GSK	211
132"	ST6R5-24132GSK	159	ST6R5-30132GSK	184	ST6R5-36132GSK	228
144"	ST6R5-24144GSK	171	ST6R5-30144GSK	199	ST6R5-36144GSK	246

ALL DIMENSIONS ARE TYPICAL. TOLERANCE +/- .500". JOHN BOOS & CO. RESERVES THE RIGHT TO CHANGE SPECIFICATIONS WITHOUT NOTICE.