



GAS

PRO SERIES | OPEN POT FRYERS



IFS-50-OP

Shown with optional casters.



Robotic welding is precise, virtually eliminating leaks.

OPEN POT BURNERS

- Flame heats ceramic plates located strategically outside of the frypot.
- Intense heat rapidly heats the stainless steel sides and the oil inside of the frypot.
- No tube fired burners and no air shutter adjustments needed.
- Snap acting thermostat has a 200°F - 400°F (93°C - 204°C) temperature range that extends oil life and produces a uniformly cooked product.
- 100% safety shut-off valve.

EXTERIOR FEATURES

- Stainless steel front, door, sides, basket hanger and frypot.
- Welded and polished stainless steel seams.
- Full heat shield protects control panel.
- Full bottom chassis provides structural support.
- Plate mounted 6" high (152 mm) heavy duty stainless steel legs or optional casters assure secure support.
- One year parts and labor warranty. Limited warranty on frypot, stainless steel frypot is five years pro-rated.

STAINLESS STEEL FRYPOTS

- Open pot frypot is easy to clean with no obstruction to clean around.
- Large 14" x 14" (356 x 356) frying area.
- Frypot sides are robotically welded stainless steel to virtually eliminate leaks.
- Fine mesh wire crumb screen is included.
- Deep drawn bottom facilitates draining, slants toward the drain.
- 1-1/4" (32 mm) full port drain valve empties frypot quickly and safely.
- Two large, nickel-plated fry baskets with vinyl coated, heat protective handles are included.
- Basket hangers are stainless steel.

LARGE COOL ZONE

- Captures and holds particles out of the fry zone
- Reduces taste transfer



1128 Sherborn Street | Corona, CA 92879 | 800.343.7790 | imperialrange.com | imperialsales@imperialrange.com

© 2026 Imperial Commercial Cooking Equipment Imperial reserves the right to change specifications at any time without prior notice and without any obligation for past or future equipment purchases. Visit www.imperialrange.com for specification updates



GAS

SPEC SERIES | TUBED FIRED FRYERS

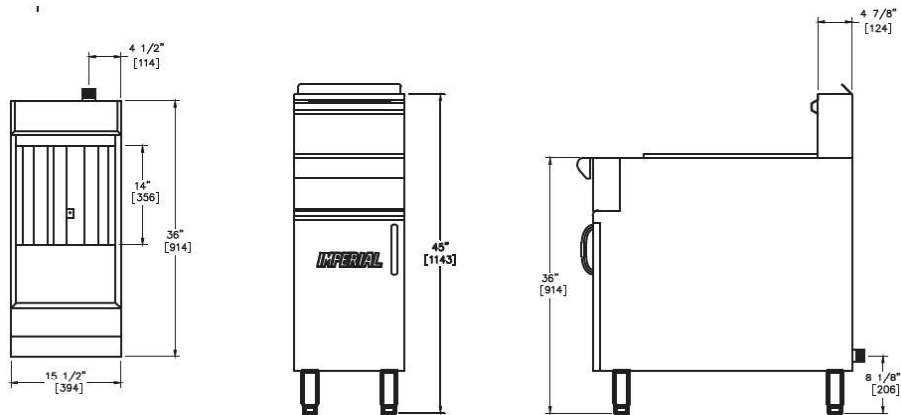

| MODEL | OIL CAPACITY | GAS OUTPUT | | #OF BURNERS | SHIP WEIGHT (KG) LBS |
|-----------|----------------|------------|------|-------------|----------------------|
| | | BTU | (KW) | | |
| IFS-50-OP | 50 lbs. (27 L) | 140,000 | (41) | 3 | (114) 253 |
| IF-DS | N/A | N/A | N/A | N/A | (60) 130 |

| MANIFOLD PRESSURE | | MANIFOLD SIZE |
|-------------------|------------|---------------|
| NAT GAS | PROPANE | |
| 4.0" W.C. | 10.0" W.C. | 3/4" (19MM) |

Specify elevation, if over 2,000 ft.

| MODEL | FRYER AREA | DIMENSIONS | CRATED DIMENSIONS |
|-----------|-----------------------------|--|---|
| IFS-50-OP | 14" X 14" (356 X 356 MM) | 15 1/2" W X 30 1/2" D X 45 3/4" H (394 X 775 X 1162 MM) | 18" W X 34" D X 35" H (457 X 864 X 889 MM) |
| IF-DS | N/A | 15 1/2" W X 30 1/2" D X 44 1/4" H (394 X 775 X 1124 MM) | 17" W X 34" D X 38" H (432 X 864 X 965 MM) |

Measurements in () are metric equivalents

OPTIONS AND ACCESSORIES

- Stainless steel backguard, no shelf
- Fryer drain station with storage cabinet
- Automatic basket lifts
- Computer controls
- Manual timer
- Extra fry baskets with vinyl coated handles
- Gas shut-off valve, 3/4" N.P.T.
- Quick disconnect and flexible gas hose, 3/4" or 1 1/4, N.P.T.
- Fryer Tip Brush
- Goofer Declogger Rod
- Sediment Scooper
- 6" (152 mm) casters

CLEARANCE REQUIREMENTS

For use only on non-combustible floors. Legs or casters are required for non-combustible floors; or 2" (51 mm) overhang is required when curb mounted. Provide 0" clearance from non-combustible surfaces and 6" (152 mm) from combustible side walls and 0" from combustible wall at rear.



MADE IN USA



1128 Sherborn Street | Corona, CA 92879 | 800.343.7790 | imperialrange.com | imperialsales@imperialrange.com

©2026 Imperial Commercial Cooking Equipment. Imperial reserves the right to change specifications at any time without prior notice and without any obligation for past or future equipment purchases. Visit www.imperialrange.com for specification updates