



Project _____
 AIA # _____ SIS # _____
 Item # _____ Quantity _____ C.S.I. Section 114000



LXGePR-ADA *advansys* LOW TEMPERATURE Undercounter



LXGePR-ADA



SPECIFIER STATEMENT

Specified unit will be NSF rated, ADA compliant Advansys undercounter with cold water sanitization featuring PuriRinse potable water rinse cycle. 38 or 29 racks per hour, 1.14 gallons per rack, soft start, auto clean, auto chemical sensing, LED temp and operator display, service diagnostics, detergent, rinse aid, sanitizer and delime pumps. Constructed of stainless steel.

1 year parts and labor warranty.

STANDARD FEATURES

- + ADA compliant – compact 31" unit height fits easily under 34" ADA countertops
- + Racks per hour – Light 38 / Normal 29
- + 1.14 gallons of water per rack
- + PuriRinse cycle (potable water rinse to remove chemical residue)
- + Low chemical alert indicators
- + Soft start
- + Chemical pump “auto-prime”
- + Advanced service diagnostics
- + Clogged wash arm sensing
- + Single, cold water connection
- + Custom cycle selection – light, normal
- + Automated delime cycle
- + Deep drawn stainless steel tank
- + Top-mounted controls with advanced digital cycle/temperature display
- + Revolving upper and lower anti-clogging wash arms
- + Snap in revolving upper and lower rinse arms
- + Removable stainless steel scrap screen
- + Corrosion resistant pump
- + Energy saver mode
- + Automatic pumped drain
- + 12" door opening
- + Dirty water indicator
- + Automatic fill
- + One dishrack – standard 20" x 20"
- + Detergent, rinse aid, sanitizer and delime pumps standard
- + Electric tank heat
- + Auto clean cycle washes down inside of machine at shutdown

OPTIONS & ACCESSORIES (Available at extra cost)

- Power cord kits
- DWT-LXe drain water tempering kit – to comply with plumbing codes
- Wine rack
- Splash reduction panel
- External casters

LXGe SERIES – LXGePR-ADA *advansys* LOW TEMPERATURE

Approved by _____ Date _____ Approved by _____ Date _____



LXGePR-ADA *advansys* LOW TEMPERATURE Undercounter

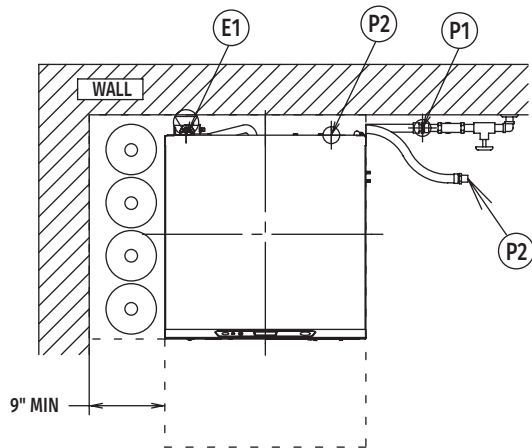

Top View

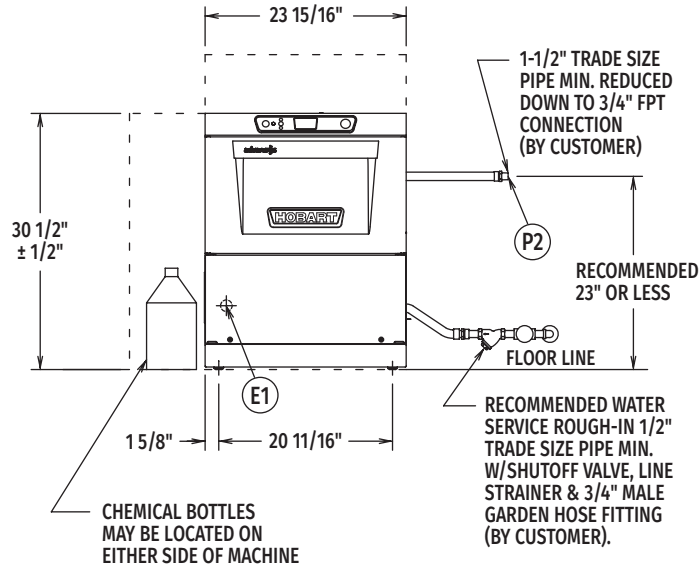

Front View

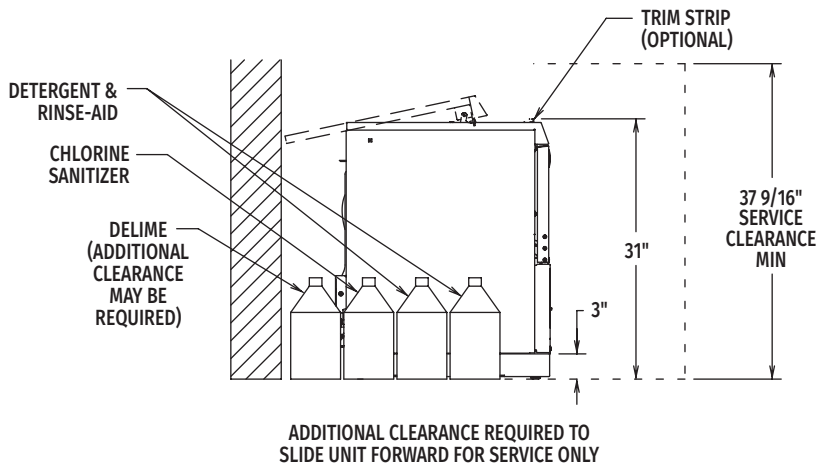

Left Side View

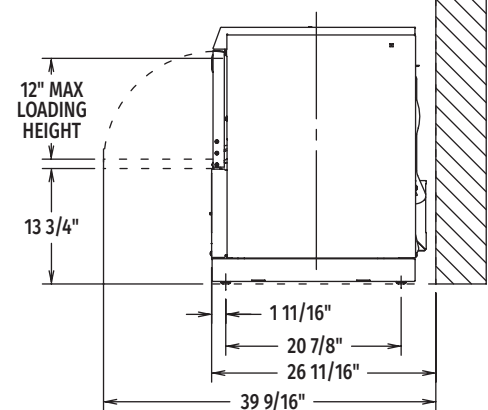

Right Side View

MODEL:
LXGePR FOOT
00-950419
REV C



LXGePR-ADA *advansys* LOW TEMPERATURE Undercounter

LEGEND

Electrical Connections	
E1	Electrical connection: 1-3/8" dia. hole for 1" trade size conduit; 10-5/8" AFF.
Plumbing Connections	
P1	Single fill and rinse connection: 3/4" female garden hose fitting on 6' long hose supplied with machine; 120°F water minimum for LXGePR, 140°F recommended.
P2	Drain connection: 5/8" barb fitting with 6' long hose supplied with machine.

WARNING: Plumbing and electrical connections should be made by qualified personnel who will observe all the applicable plumbing, sanitary, safety codes and National Electrical Code.

Required flowing pressure to the dishmachine is 15-65 PSIG. If pressures higher than 65 PSIG are present, a pressure regulating valve must be installed in the water line to the dishmachine (by others).

Pressure gauge not required on pumped rinse machines.

(E1) STANDARD ELECTRICAL OPTIONS

Tank Heat, Booster, Pump & Controls			
Voltage	Rated Amps	Minimum Supply Circuit Ampacity	Maximum Protective Device
120/60/1	15.4	20	20

NOTE: For supply connections, use copper wire only rated at 90°C minimum.

Accessory cord kit available for all models.

SPECIFICATIONS

Capacities

Cycle Time (seconds)	Light 94 / Normal 124
Racks per Hour	Light 38 / Normal 29
Tank Capacity – Gallons	2.9

Motor Horsepower

Wash	.085
Rinse	.019

Water Consumption

U.S. Gallons per Rack (maximum use)	1.14
U.S. Gallons per Hour (maximum use)	33.0
Peak Drain Flow – U.S. Gallons per Minute	4.0

Temperatures °F

Incoming Water Temperature (minimum)	120
--------------------------------------	-----

Heating

Tank Heat, electric (kW)	1.8
--------------------------	-----

Standard 20" x 20" Rack

Flat	1
Peg	1

Shipping Weight (approximate) 170 lbs.

Crated Dimensions 27"W x 30"L x 37"H

Heat Output, BTU/Hour	
Latent	Sensible
1,900	800