

"OSC2R" OVERSHELVES - CANTILEVERED

Double Shelf, 16GA w/1½" Rear Riser

FEATURES:

- Stainless Steel Shelf With Stallion Safety Edge On Front And 1-1/2" Turnup On Rear
- 16GA, Type 300 Stainless Steel With #4 Polish, Satin Finish
- Uprights Are 1-1/2" Square 14GA Tubing, Type 300 Stainless Steel With #4 Polish, Satin Finish
- Single Overshelves Are Mounted 18" Above Table Top
- Double Overshelves Are Mounted 12" Above First Shelf
- Overshelves Feature Knockdown Setup
- All Models Are Approved By The National Sanitation Foundation

SPECIFICATIONS:

- Stainless Steel Overshelves Are TIG Welded
- Exposed Welds Are Polished To Match Adjacent Surfaces
- Shelf: 16GA, Type 300 Stainless Steel, #4 Polish, Satin Finish
- Uprights: 1-1/2" Square 14GA Tubing, 14GA Type 300 Tubular Stainless Steel #4 Polish, Satin Finish
- Heat Lamp Provision: OSEHLP-6XX 6=Width Of Provision, XX=Nominal Length Of Shelf

CERTIFICATIONS:



OSC26RK-1236

"OSC2R" CANTILEVERED OVERSHELVES

LENGTH (L)	12" WIDTH	WT. (LBS)	18" WIDTH	WT. (LBS)
36"	OSC26RK-1236	48	OSC26RK-1836	52
48"	OSC26RK-1248	52	OSC26RK-1848	62
60"	OSC26RK-1260	56	OSC26RK-1860	72
72"	OSC26RK-1272	60	OSC26RK-1872	82
84"	OSC26RK-1284	70	OSC26RK-1884	100
96"	OSC26RK-1296	75	OSC26RK-1896	109
108"	OSC26RK-12108	80	OSC26RK-18108	118
120"	OSC26RK-12120	85	OSC26RK-18120	126
132"	OSC26RK-12132	92	OSC26RK-18132	135
144"	OSC26RK-12144	98	OSC26RK-18144	144

ALL DIMENSIONS ARE TYPICAL. TOLERANCE +/- .500". JOHN BOOS & CO. RESERVES THE RIGHT TO CHANGE SPECIFICATIONS WITHOUT NOTICE.

DETAILED SPECIFICATIONS

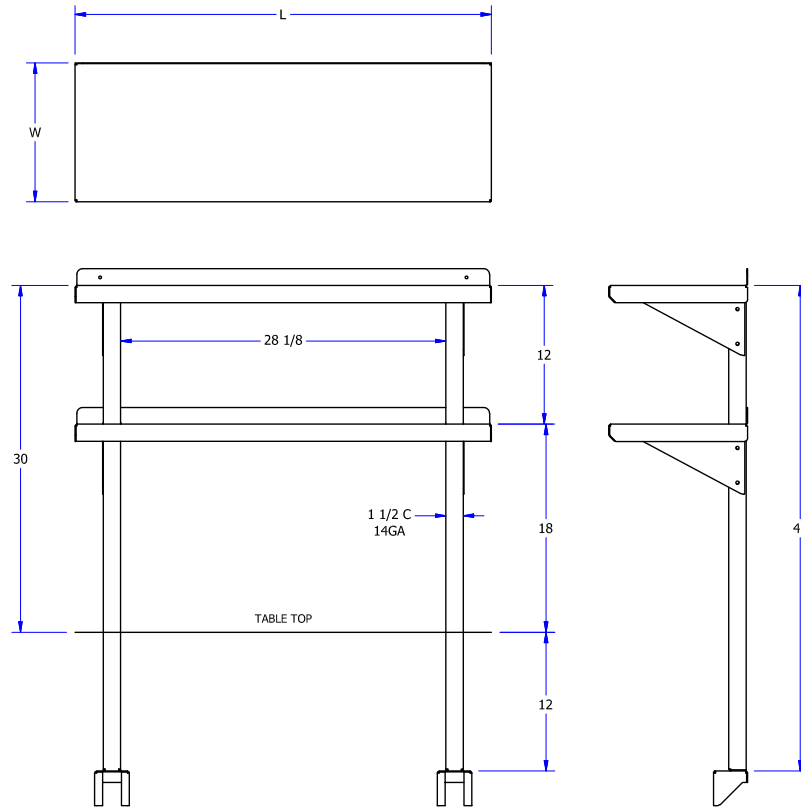

MODEL # STRUCTURE

16 = GA
 2 = # OF SHELVES
 C = CANTILEVERED
 OS = OVERSHELF

R = RISER TOP
 K = KNOCKDOWN
 12 = WIDTH (FRONT/BACK)
 36 = LENGTH (LEFT/RIGHT)

OSC26RK-1236

"OSC2R" CANTILEVERED OVERSHELVES

LENGTH (L)	12" WIDTH	WT. (LBS)	18" WIDTH	WT. (LBS)
36"	OSC26RK-1236	48	OSC26RK-1836	52
48"	OSC26RK-1248	52	OSC26RK-1848	62
60"	OSC26RK-1260	56	OSC26RK-1860	72
72"	OSC26RK-1272	60	OSC26RK-1872	82
84"	OSC26RK-1284	70	OSC26RK-1884	100
96"	OSC26RK-1296	75	OSC26RK-1896	109
108"	OSC26RK-12108	80	OSC26RK-18108	118
120"	OSC26RK-12120	85	OSC26RK-18120	126
132"	OSC26RK-12132	92	OSC26RK-18132	135
144"	OSC26RK-12144	98	OSC26RK-18144	144

ALL DIMENSIONS ARE TYPICAL. TOLERANCE +/- .500". JOHN BOOS & CO. RESERVES THE RIGHT TO CHANGE SPECIFICATIONS WITHOUT NOTICE.