

# Dual Select BIB (No Timer; Rckr Switch)

Model No. 2257-00-220

## Specifications

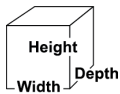
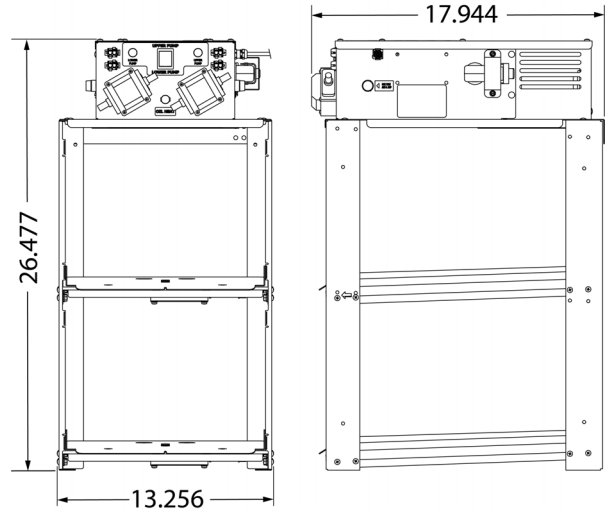

### Overall Dimensions:

**Width:** 13.256" (33.7 cm)

**Depth:** 17.944" (45.6 cm)

**Height:** 26.477" (67.3 cm)

### Electrical - Domestic

120V

340 WATTS    60 Hz

**Plug Type:**



**Agency Approvals:**



### Dual Select Features:

- **Rocker switch** to select UPPER or LOWER box of oil.
- **No Timer unit**—the popper controls dispense timing.
- 2 oil pumps (a dedicated pump for each box of oil).
- Holds (2) 35-pound boxes of oil.
- Load Cell Sensor for each box to detect oil level (for poppers with load sensing capability).
- Heater/blower and heated oil lines on both pumps.
- Equipped w/ 6 Pin Plug Assy—unit powered by popper.

### Popper Requirements for Use:

- PopClean unit (with a Touch Screen Control) or Cornado (with a programmable oil timer on the electronic control).
- Popper must have **2 heated oil lines** to connect to unit; (Retrofit Oil Line Kit available, if applicable; see below).

### Optional - Retrofit Oil Line Kit (all sold separately)

A second oil line kit for applicable poppers; customer responsibility to have qualified service install the kit.

- Popper Oil Line Kit (PN 115854)
- Cornado Popper Oil Line Kit (pending release)



**Gold Medal Products Co.**  
10700 Medallion Drive, Cincinnati, OH 45241

Ph: (513) 769-7676, (800) 543-0862; Fax: (513) 769-8500  
gmpopcorn.com    info@gmpopcorn.com