

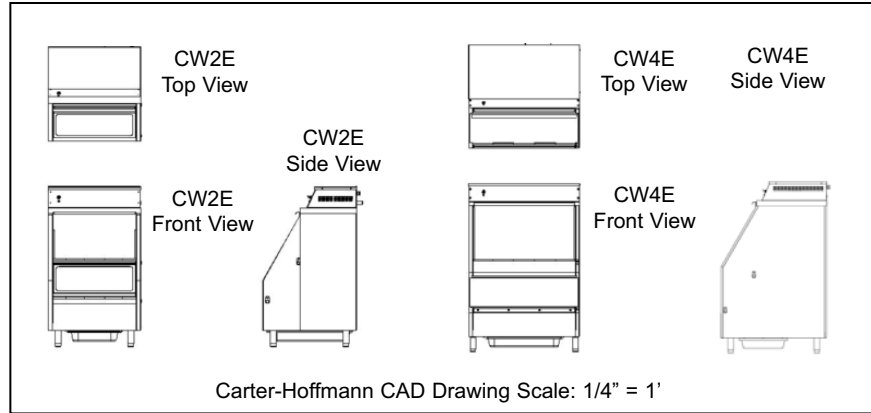

CW2E & CW4E NACHO CHIP WARMERS (with top-mounted forced air heating system)



Carter-Hoffmann CAD Drawing Scale: 1/4" = 1'

Model Number	Capacity Cubic Feet*	Overall Dimensions						Legs		Shipping Weight	
		Height		Depth		Width		in	mm	lbs	kgs
		in	mm	in	mm	in	mm				
<input type="checkbox"/> CW2E	3.00	38 ³ / ₄	984	23	584	22 ³ / ₄	578	4	102	135	61
<input type="checkbox"/> CW4E	5.75	45 ⁵ / ₈	1158	27 ⁷ / ₈	708	30 ¹ / ₈	765	4	102	175	79

*Approximately 22 gallons of chips in CW2E and 44 gallons of chips in CW4E.

CONSTRUCTION... Completely welded cabinet construction with outer cabinet welded to cabinet liner. Extended side panels reduce chip spillage.

CABINET MATERIAL... All stainless steel construction

INSULATION... High density fiberglass, full 1" thick continuous wrap-around type in top, bottom and sides.

DOORS... 16 gauge single panel polished stainless steel.

HINGES... Integral and continuous rolled butt type hinges. Removable stainless steel full length pin.

LEGS... 4" adjustable legs

HANDLES... Bottom door and product loading door feature integrally formed, full width stainless steel handles.

BOTTOM CRUMB PAN... Standard 12"x20"x2.5" stainless steel pan, mounted on bottom of unit to catch crumbs. Slides out for easy cleaning.

CONTROLS... Internal mechanical thermostat. Factory pre-set temperature of 175°F (79°C). Adjustable with tools via access hole with grommet; located on rear of heating unit. On/off switch with power indicating light.

HEATING SYSTEM... Top mounted lift off forced air heating system. Incoloy-sheathed heating elements, heavy duty fan motor. Air forced through rear duct and up through bottom chip grates. Duct and grates removable for cleaning.

ELECTRICAL CHARACTERISTICS... CW2E & CW4E operate on 1530 watts, 12.6 amps, 60 cycle, single phase. Six foot 3 wire rubber cord with 3 prong grounding plug. NEMA 5-15P.

PERFORMANCE... Capable of heating to 190° F (88° C). Preheat to 160° F (71° C) in approximately 20 minutes.

ACCESSORIES/OPTIONS...

- 18 gauge stainless steel rolling stand with 3" stem casters, two with brakes
- 1/4" thick clear polycarbonate viewing window in bottom door
- 220 or 240 volt electrical configuration

SPECIFICATIONS

Specifications subject to change through product improvement & innovation.



CARTER-HOFFMANN
1551 McCormick Ave., Mundelein, IL 60060
Tel (847) 362-5500 • (800) 323-9793 • Fax (847) 367-8981
www.carter-hoffmann.com

FEATURES & BENEFITS

1551 McCormick Avenue, Mundelein, Illinois 60060
Tel (847) 362-5500 • (800) 323-9793 • Fax (847) 367-8981
www.carter-hoffmann.com



CW2E & CW4E NACHO CHIP WARMERS

Since 1947, Foodservice Equipment That Delivers!

STAINLESS STEEL CONSTRUCTION... All stainless steel exterior for easy sanitation and long lasting clean appearance.

PATENTED FIRST-IN, FIRST-OUT GRAVITY PRODUCT FEED... Facilitates constant product rotation to ensure freshness.

LARGE CHIP CAPACITY... Provides ample supply of product, even during peak rush periods. Approximately 44 gallons in CW4E and 22 gallons in CW2E.

VERSATILE... In addition to tortilla chips, these warmers are ideal for kettle chips and even foil-wrapped baked potatoes!

HIGH PERFORMANCE CONVECTION HEATER... Heating system located in top of cabinet with blower for quick heat up and recovery and even heat distribution throughout cabinet. Thermostat for optimal holding temperature located on rear of cabinet; accessible & adjustable with tools to prevent easy tampering. Heater lifts off for easy cleaning and service.

EXTENDED SIDE PANELS... Provide a barrier on each side to reduce spillage and food waste during service.



CW2E

EXCLUSIVE HEAT DUCT BAFFLING SYSTEM... Warm air is directed through duct in back of cabinet and up through chips on the bottom. Assures uniform temperatures throughout cabinet for consistent holding of product.



BOTTOM CRUMB PAN... Catches broken chips and crumbs. Easily removed without tools for cleaning. Standard steam table size is easily replaceable.



NSF/ANSI 4