

"OSE16F" OVERSHELVES - ECONOMY SERIES

Single Tier, 16GA w/Flat Top

FEATURES:

- Stainless Steel Shelf With Stallion Safety Edge On Front And Rear
- 16GA, Type 300 Stainless Steel With #4 Polish, Satin Finish
- Uprights Are 1" O.D. Round 18GA Tubing, Type 300 Stainless Steel With #4 Polish, Satin Finish
- Rear Or Center Mount (Please Specify)
- Single Overshelves Are Mounted 18" Above Table Top
- Overshelves Feature Knockdown Setup All Models Are Approved By The National Sanitation Foundation

SPECIFICATIONS:

- Stainless Steel Overshelves Are TIG Welded
- Exposed Welds Are Polished To Match Adjacent Surfaces
- Shelf: 16GA, Type 300 Stainless Steel, #4 Polish, Satin Finish
- Uprights: 1" Round O.D., 18GA Type 300 Tubular Stainless Steel #4 Polish, Satin Finish
- Heat Lamp Provision: OSEHLP-6XX 6=Width Of Provision, XX=Nominal Length Of Shelf



OSE16FK-1260

CERTIFICATIONS:



"OSE16F" OVERHSHELVES - ECONOMY SERIES

LENGTH	12" WIDTH	WT (LBS)	18" WIDTH	WT (LBS)
36"	OSE16FK-1236	14	OSE16FK-1836	18
48"	OSE16FK-1248	16	OSE16FK-1848	22
60"	OSE16FK-1260	19	OSE16FK-1860	26
72"	OSE16FK-1272	22	OSE16FK-1872	31
84"	OSE16FK-1284	25	OSE16FK-1884	35
96"	OSE16FK-1296	28	OSE16FK-1896	40
108"	OSE16FK-12108	31	OSE16FK-18108	44
120"	OSE16FK-12120	36	OSE16FK-18120	49
132"	OSE16FK-12132	40	OSE16FK-18132	53
144"	OSE16FK-12144	45	OSE16FK-18144	57

ALL DIMENSIONS ARE TYPICAL. TOLERANCE +/- .500". JOHN BOOS & CO. RESERVES THE RIGHT TO CHANGE SPECIFICATIONS WITHOUT NOTICE.

DETAILED SPECIFICATIONS

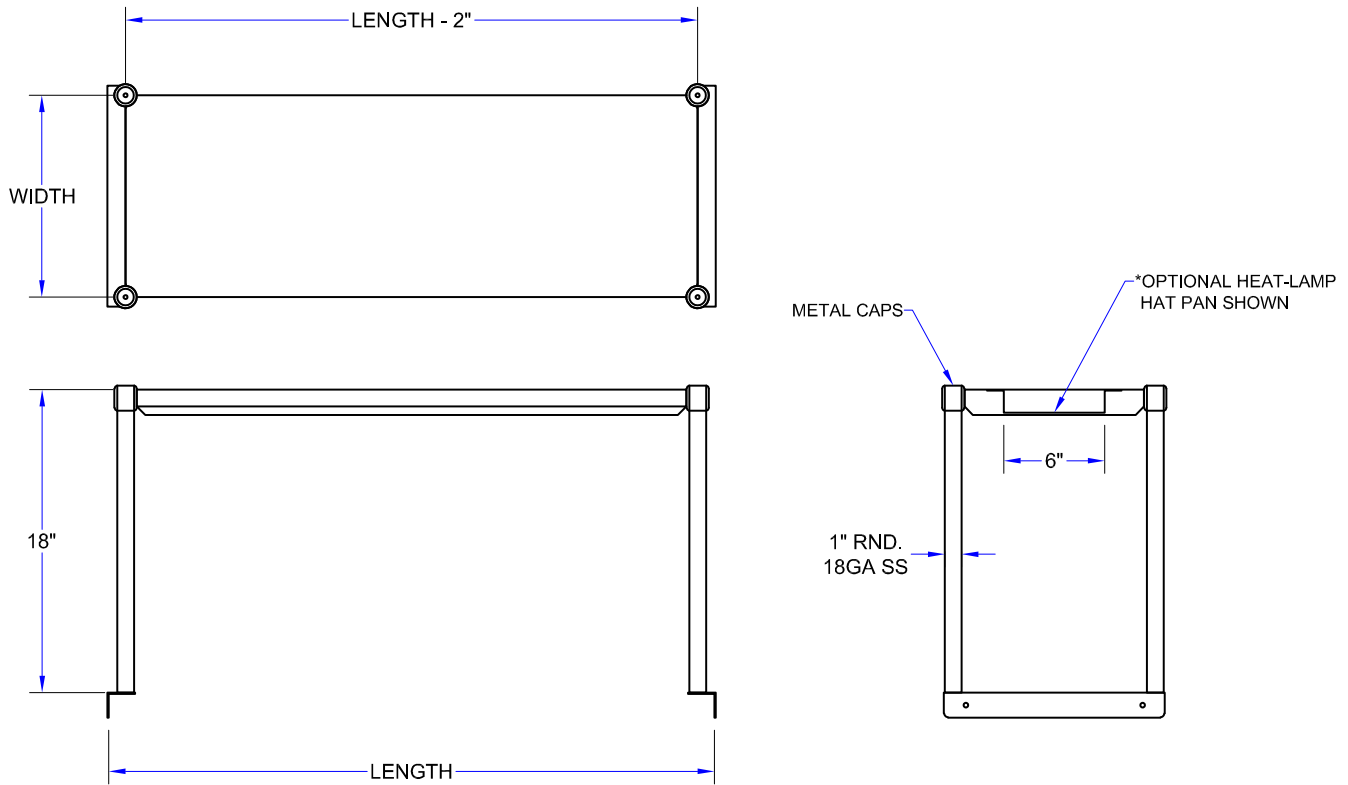

MODEL # STRUCTURE

16 = GA
 1 = # OF SHELVES
 E = ECONOMY
 OS = OVERSHELF

F = FLAT TOP
 K = KNOCKDOWN
 12 = WIDTH (FRONT/BACK)
 36 = LENGTH (LEFT/RIGHT)

OSE16FK-1236

"OSE16F" OVERHSHELVES - ECONOMY SERIES

LENGTH	12" WIDTH	WT (LBS)	18" WIDTH	WT (LBS)
36"	OSE16FK-1236	14	OSE16FK-1836	18
48"	OSE16FK-1248	16	OSE16FK-1848	22
60"	OSE16FK-1260	19	OSE16FK-1860	26
72"	OSE16FK-1272	22	OSE16FK-1872	31
84"	OSE16FK-1284	25	OSE16FK-1884	35
96"	OSE16FK-1296	28	OSE16FK-1896	40
108"	OSE16FK-12108	31	OSE16FK-18108	44
120"	OSE16FK-12120	36	OSE16FK-18120	49
132"	OSE16FK-12132	40	OSE16FK-18132	53
144"	OSE16FK-12144	45	OSE16FK-18144	57

ALL DIMENSIONS ARE TYPICAL. TOLERANCE +/- .500". JOHN BOOS & CO. RESERVES THE RIGHT TO CHANGE SPECIFICATIONS WITHOUT NOTICE.