



MODEL SHO-100-G
Full-Size Gas Convection Oven
(Formerly called SHO-G)



SHO-100-G

Project _____

Item No. _____

Quantity _____

Standard depth baking compartment - accepts five 18" x 26" standard full-size baking pans in left-to-right positions.

All data is shown per oven section, unless otherwise indicated.

Refer to operator manual specification chart for listed model names.

EXTERIOR CONSTRUCTION

- Full angle-iron frame
- Stainless steel front, top, and sides
- Dual pane thermal glass window
- Tubular black soft touch handle with simultaneous door operation
- Triple-mounted pressure lock door design with turnbuckle assembly
- Removable front control panel
- Solid mineral fiber insulation at top, back, sides and bottom

INTERIOR CONSTRUCTION

- Double-sided porcelainized baking compartment liner (14 gauge)
- Aluminized steel combustion chamber
- Dual inlet blower wheel
- Five chrome-plated racks, eleven rack positions with a minimum of 1-5/8" (41mm) spacing
- Interior lights

OPERATION

- Dual Flow Gas system combines direct and indirect heat
- Electronic spark ignition control system
- Removable dual tube burners
- Pressure regulator and manual gas service cut-off valve located in front control area
- Air mixers with adjustable air shutters
- Solid state thermostat with temperature control range of 200°F (93°C) to 500°F (260°C)
- Two speed fan motor
- 1/2 horsepower blower motor with automatic thermal overload protection
- Control area cooling fan

STANDARD FEATURES

- SSM - Solid state manual control with separate dials to control thermostat and timer
- 25" (635mm) adjustable stainless steel legs (for single units)
- 6" (152mm) adjustable stainless steel legs (for double sections)
- Draft diverter or draft hood for venting (select one)
- One year oven parts and labor warranty*

** For all international markets, contact your local distributor.*

OPTIONS AND ACCESSORIES

(AT ADDITIONAL CHARGE)

■ **Legs/casters/stands:**

- 6" (152mm) seismic legs
- 6" (152mm) casters
- 4" (102mm) low profile casters (double only)
- 25" (635mm) stainless steel stand w/rack guides
- 29" (737mm) stainless steel, fully welded open stand with pan supports

■ **Gas hose with quick disconnect and restraining device:**

- 48" (1219mm) hose
- 36" (914mm) hose
- Extra oven racks
- Gas manifold (for double sections)
- Flue connector



BLODGETT OVEN COMPANY

www.blodgett.com • 42 Allen Martin Drive, Essex Junction, VT 05452 • Phone: (802) 658-6600 • Fax: (802) 864-0183



SHO-100-G

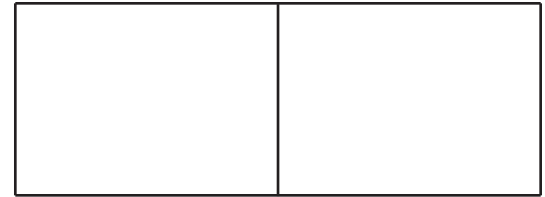

APPROVAL/STAMP

DIMENSIONS ARE IN INCHES (MM)

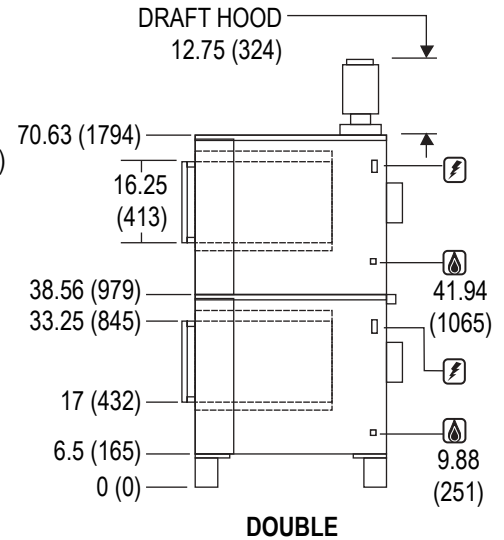
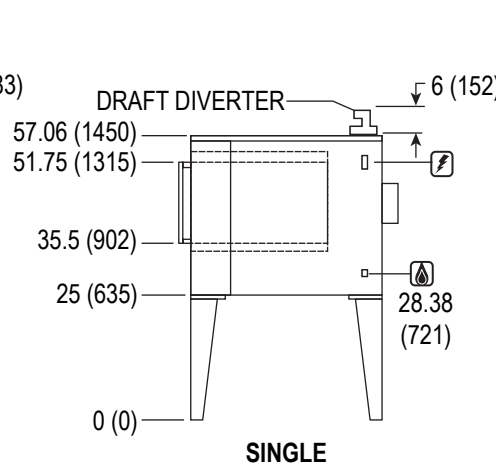
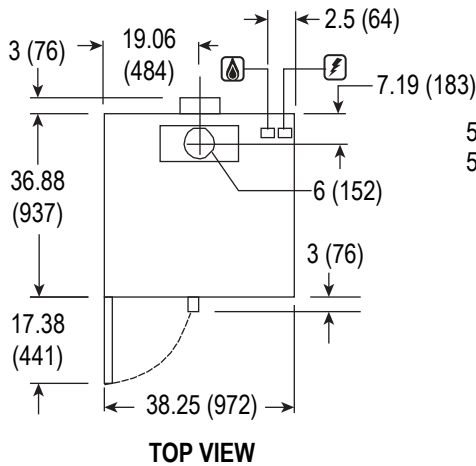

SHORT FORM SPECIFICATIONS: Provide Blodgett full-size convection oven model SHO-100-G, (single/double) compartment. Each compartment shall have (porcelainized/stainless) steel liner and shall accept five 18" x 26" standard full-size bake pans. Stainless steel front, top and sides. Door shall be stainless with dual pane thermal glass. Door shall have single tubular black soft touch handle and simultaneous operation. Unit shall be gas heated with electronic spark ignition and shall cook by means of a dual-flow system combining direct and indirect heat. Air in baking chamber distributed by dual inlet blower wheel powered by a two-speed, 1/2 HP motor with thermal overload protection. Each chamber shall be fitted with five chrome-plated removable racks and interior lights. Control panel shall be recessed with Cook/Cool Down mode selector, solid state (manual/digital) infinite thermostat (200- 500°F), and 60-minute timer. Provide options and accessories as indicated.

DIMENSIONS:

- Floor space 38-1/4" (972mm) W x 36-7/8" (937mm) D
- Product clearance:**
- Oven Back 0" from combustible and non-combustible construction
- Oven Sides 2" from combustible and non-combustible construction
- Interior 29" (737mm) W x 20" (508mm) H x 24-1/4" (616mm) D
- If oven is on casters:**
- Single Add 4-1/2" (114mm) to all height dimensions
- Double Dimensions do not change
- Double Low Profile Subtract 2-1/2" (64mm) from all dimensions

GAS SUPPLY:

- 3/4" NPT
- Manifold Pressure:**
- Natural 3.5" W.C
- Propane 10" W.C.

Inlet Pressure:

- Natural 7.0" W.C. min. – 10.5" W.C. max.
- Propane 11.0" W.C. min. – 13.0" W.C. max.

MAXIMUM INPUT:

- Single 50,000 BTU/hr (14.6 Kw)
- Double 100,000 BTU/hr (29.2 Kw)

POWER SUPPLY:

- 115 VAC, 1 phase, 6 amp, 60 Hz., 2-wire with ground,
- 1/2 H.P., 2 speed motor, 1120 and 1710 RPM
- 6' (1.8m) electric cord set furnished on 115 VAC ovens only.
- Blodgett recommends a Pass & Seymour, model 2097, GFCI due to the use of a variable frequency drive. Must be hard wired in some cases.

MINIMUM ENTRY CLEARANCE:

- Uncrated 32-1/16" (814mm)
- Crated 37-1/2" (953mm)

SHIPPING INFORMATION:

- Approx. Weight:**
- Single 541 lbs. (245 kg)
- Double 1048 lbs. (475 kg)
- Crate sizes:**
- 37-1/2" (952mm) x 43-1/2" (1105mm) x 51-3/4" (1315mm)

NOTE: The company reserves the right to make substitutions of components without prior notice

BLODGETT OVEN COMPANY

www.blodgett.com • 42 Allen Martin Drive, Essex Junction, VT 05452 • Phone: (802) 658-6600 • Fax: (802) 864-0183