

BASE MODEL FREEZER (0°F)

Model: FA43NBS

Natural Refrigerant R-290 Model

43" Worktop Freezer with Solid Doors and 5 1/2" Backsplash

Heavy gauge #300 Series stainless steel top, stainless steel front and end panels, galvanized steel rear and grill and aluminum interior.

Designed to maintain NSF-7 temperatures in 100°F ambient.



Options and Accessories

(upcharge and lead times may apply)

Stainless steel interior	Different size casters
Stainless steel back	Adjustable legs
Additional epoxy coated steel shelves	Door locks
Stainless steel shelves	Front breathing
Overshelves (single or double)	Compressor left (standard on right)
Pan slides	Drawers in lieu of doors**

Drawer in lieu of door section above the condensing unit*

*Drawer above condensing unit holds (1) 12 x 20 x 6 pan

**Large drawer holds (2) 12 x 20 x 6 pans per drawer

Consult factory for other model configurations, options and accessories.

Continental
Refrigerator



Project Name:

Model Specified:

Location:

Item No:

Quantity:

AIA #:

SIS #:

Standard Model Features

REFRIGERATION SYSTEM

Performance rated refrigeration system

Environmentally safe R290 refrigerant

Unique forced air design utilizes fans (approx. every 12") across the entire back of unit for even distribution of cold

Automatic, energy saving, non-electric condensate evaporator

Non-corrosive, plasticized fin evaporator coil

Expansion valve system

Easily serviceable, slide out condensing unit

CABINET ARCHITECTURE

2" non-CFC polyurethane foam insulation

Spring loaded, self closing doors

Magnetic snap in Santoprene™ door gaskets

Heavy duty, epoxy coated steel shelf

Smooth, polished chrome door handles

5" casters

Completely enclosed, vented and removable rear and side grills

MODEL FEATURES

Electronic control, automatic electric defrost

Reversing condenser fan motor (runs for short period during startup to clear any debris)

Refrigerated section with door above the condensing unit

Field rehingeable doors

¹ R-290 refrigerant meets all federal and state regulatory requirements.

NOTE: Models come standard with a door over the condensing unit. A drawer over the condensing unit is an option.

APPROVAL:

Model Specifications

DIMENSIONAL DATA

Net Capacity (cubic feet)	12 (340 l)
Width, Overall (inches)	43 (1092 mm)
Depth, Overall (inches) (including handles & bumpers)	37 (939 mm)
Height, Overall (inches) (including 5" casters)	40 1/2 (1029 mm)
Shelf Area (square feet)	5.6 (0.5 sq m)
Number of Shelves	2
Number of Full Doors	1
Number of Half Doors	1
Interior Depth (inches)	30 (762 mm)
Interior Height (inches)	26 (660 mm)
Interior Height (inches) (above condenser)	12 1/2 (318 mm)
Interior Width (inches)	39 (991 mm)

REFRIGERANT DATA

Condensing Unit Size (H.P.)	1/3
R-290 Refrigerant Charge (oz)	4.3
Capacity (BTU per hour)*	1030

ELECTRICAL DATA

Voltage (International)	115/60/1 (220/50/1)
Total Amps (International)	3.6 (1.8)
Defrost Amps (International)	6.6 (3.3)
10 ft. Cord/Plug [attached] (International)	Yes (No)

SHIPPING DATA

Weight (pounds)	325 (148 kg)
Height - Crated (inches)	45 (1111 mm)
Width - Crated (inches)	52 (1143 mm)
Depth - Crated (inches)	39 (1194 mm)

* Rating @ -15°F evaporator, 90°F ambient
Figures in parentheses reflect metric equivalents rounded to the nearest whole unit.



Equipped with one NEMA-5-15P Plug
(varies by country)

Model Plan Views

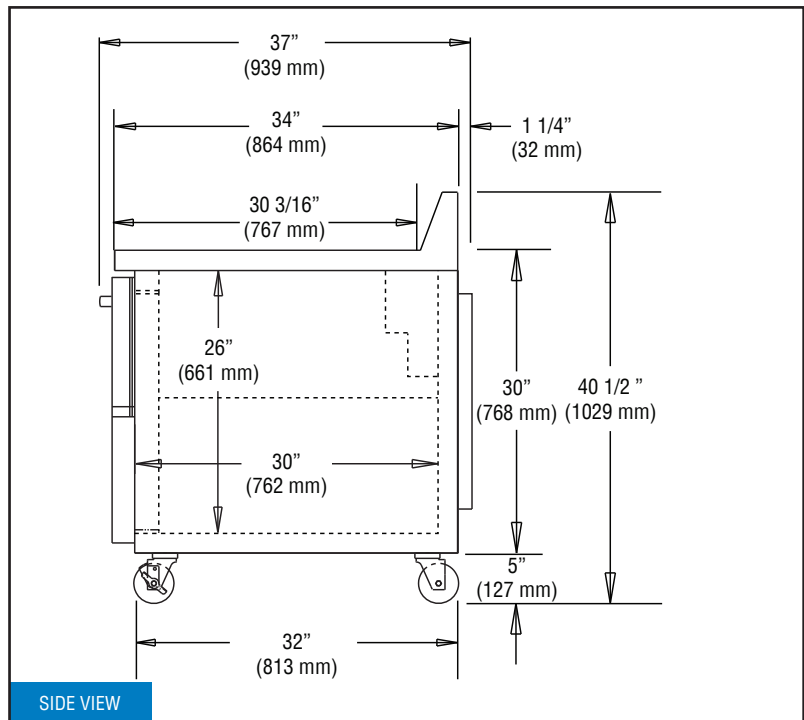
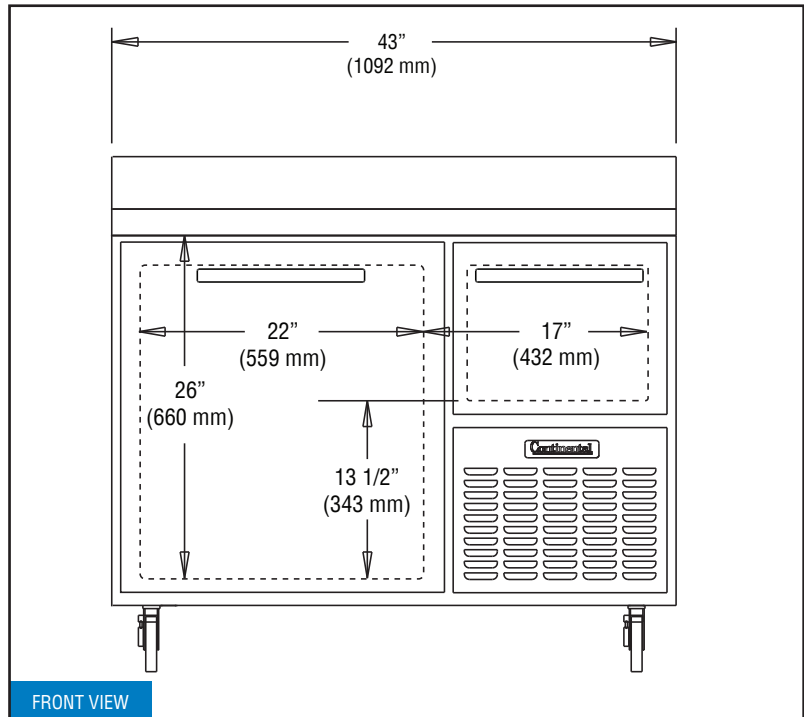

Continental
Refrigerator

Toll-Free: 800-523-7138
Phone: 215-244-1400
Fax: 215-244-9579

539 Dunksferry Road
Bensalem, PA 19020
www.continentalrefrigerator.com

Due to our continued efforts in developing innovative products, specifications subject to change without notice.



PROUDLY
DESIGNED & ASSEMBLED
IN THE U.S.A.

Intertek

© Copyright 2024. Continental Refrigerator.

REVISED: 4/30/26